



PRO  
LYFT

AETOS Range



PROLYTE  
GROUP

## OPERATING AND MAINTENANCE MANUAL

### AETOS Models:

PAE-250DC-XXXX  
PAE-250LV-XXXX(H)  
PAE-500DC-XXXX  
PAE-500LV-XXXX(H)  
PAE-1000DC-XXXX  
PAE-1000LV-XXXX(H)





## **CONGRATULATIONS**

Congratulations with the purchase of your new **PROLYFT** AETOS hoist.

### **Register your hoist**

In order to activate to the Lifetime Warranty Program your hoist needs to be registered within 1 month after the purchase date. Please follow the instructions on the separate Lifetime Warranty information letter included in the box, or go to [www.prolyft.com](http://www.prolyft.com) and select "register your hoist".

### **Lifetime Warranty**

Prolyte offers a unique Lifetime Warranty system. Each **PROLYFT** hoist is equipped with an electronic tag, which enables the owner to keep track of the hoists' history in an easy accessible **PROLYFT** Service Base.

The Lifetime Warranty program is applicable as long as you service and re-certify your hoist yearly at a **PROLYFT** Service Point. Your nearest Service Point can be found by the "Prolyte Locator App", through our website or at the back of this manual.

### **Content of the box or flight case**

You have received the hoist in a box or a flight case. The following should be included:

- The hoist.
- 1 Chain hook.
- 1 Chain end stop.
- 2 foam stoppers.
- 1 washer to hold foam stopper
- 1 chain bag bracket, including bolt and nut (optional)
- 1 chain bag (optional)
- The required length of chain (optional)
- Lifetime Warranty information letter
- Test Certification document
- Manual

### **Before you start using the hoist**

Before starting to use the hoist please take care of the following:

- Check the carton box or the flight-case for any transport damage. Contact your supplier if there is any damage found.
- Look in the box for the test-certificate with the serial number.
- Go to the website "service.prolyft.com" and register your hoist.
- Read the manual carefully.
- Check the voltage settings of the hoist. All hoist come standard with a 400V/3ph/50Hz setting.
- Take care of the proper safety features for lifting loads.
- Enjoy using the hoist.

### **Lifting over people**

Standard **PROLYFT** hoists are designed according to the European Machine Directive.

In order to use the standard **PROLYFT** hoist to lift or suspend loads above people extra measures must be taken in order to create the right safety level. These measures must be based on local regulations or on the outcome of a Risk Assessment. See chapter 10 of this manual.



<b>1. GENERAL INFORMATION</b>	<b>5</b>
<b>2. CORRECT OPERATION</b>	<b>5</b>
Lifting capacity	5
Danger zones	5
Suitable for entertainment use	5
Lifting or suspending loads over people	5
Attaching the hoist	5
Temperature range	5
Protection against rain and humidity	5
Theoretical service life	6
Regulations	6
Maintenance/Repair	6
<b>3. INCORRECT OPERATION</b>	<b>6</b>
<b>4. ASSEMBLY</b>	<b>6</b>
<b>4.1. INSPECTION BEFORE ASSEMBLY</b>	<b>6</b>
<b>4.2. ELECTRIC CHAIN HOIST WITH SWIVELING HOOK</b>	<b>6</b>
(Standard version)	6
<b>4.2. ELECTRIC CHAIN HOIST WITH SUSPENSION BRACKET (Optional)</b>	<b>7</b>
<b>4.3. ELECTRICAL CONNECTION</b>	<b>7</b>
Preparation	7
Mains supply connection 3 phases	7
Connecting to the power supply	7
Direction of rotation	7
<b>4.4. DIRECT CONTROLLED HOISTS</b>	<b>7</b>
<b>4.5. LOW VOLTAGE CONTROLLED HOISTS</b>	<b>8</b>
<b>4.6. ADDING CHAIN AND CHAIN END STOPS</b>	<b>8</b>
<b>4.7. CHAIN BAGS</b>	<b>8</b>
<b>4.8. CIRCUIT DIAGRAM</b>	<b>8</b>
<b>5. FUNCTIONAL CHECK BEFORE EVERY INSTALL</b>	<b>9</b>
<b>6. COMMISSIONING</b>	<b>10</b>
Inspection before each initial operation	10
Inspection by an expert	10
<b>7. OPERATION / USE</b>	<b>10</b>
Operator skills	10
Visual inspection before starting work	10
Inspection of load chain	10
Inspection of chain end stop	10
Inspection of chain reeving	10
Inspecting the hooks	10
Attaching the load	10
Lifting/lowering the load	11
Emergency stop	11
End limit switch	11
<b>8. SERVICE</b>	<b>11</b>
<b>8.1. GENERAL</b>	<b>11</b>
<b>8.2. PROLYFT SERVICE PROGRAM / LIFETIME WARRANTY</b>	<b>11</b>
Initial Certificate	11
Registration	11
Yearly inspection and re-certification	11
<b>8.3. DAILY CHECKS</b>	<b>11</b>
<b>8.4. INSPECTION AND MAINTENANCE CHECKLIST</b>	<b>12</b>
<b>8.5. REGULAR INSPECTIONS, SERVICE AND TESTING</b>	<b>13</b>
<b>8.6. LOAD CHAIN</b>	<b>13</b>
Lubricating the load chain	13
Inspecting the load chain for wear	13
Replace the load chain	13
1-strand design	13
2-strand design	14
Fitting the chain anchor bolt	14
Functional test	14
<b>8.7. MAINTENANCE LOAD HOOK</b>	<b>14</b>
<b>8.8. MAINTENANCE OF OVERLOAD PROTECTION DEVICE</b>	<b>15</b>
Overload protection device	15
Adjustment of overload device (Fig. 19)	15
<b>8.9. MAINTENANCE OF GEARBOX</b>	<b>15</b>
Oil change PAE-500 and PAE-1000 (Fig. 20A)	15
<b>8.10. MAINTENANCE OF MOTOR</b>	<b>16</b>
Motor	16
Spring activated disc brake	16
Replacement of brake rotor with friction lining:	16
Build-up of motor brake:	16
<b>9. ELECTRIC CHAIN HOIST IN GENERAL</b>	<b>16</b>
<b>10. LIFTING OVER PEOPLE</b>	<b>16</b>
<b>11. EXPLODED VIEW</b>	<b>17</b>
<b>12. SPARE PARTS</b>	<b>18</b>



Fig 1:

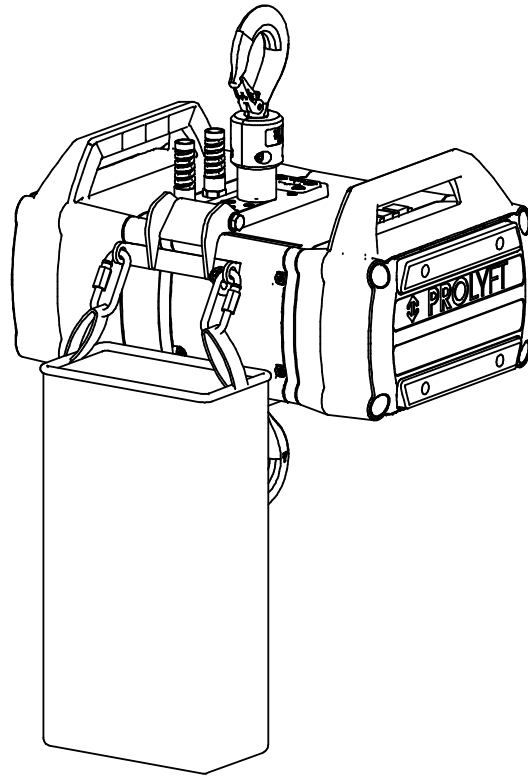

Table 1:

Model*	PAE-250DC-00XX	PAE-250DC-02XX	PAE-250DC-10XX	PAE-250DC-12XX	PAE-500DC-00XX	PAE-500DC-02XX	PAE-500DC-10XX	PAE-500DC-12XX	PAE-1000DC-00XX	PAE-1000DC-02XX	PAE-1000DC-10XX	PAE-1000DC-12XX
Capacity [kg] (D8/D8+)	250	250/125	500	500/250	500	500/250	1000	1000/500	1000	1000/500	2000	2000/1000
Number of Chain falls	1	1	2	2	1	1	2	2	1	1	2	2
Operating Voltage [V], 50Hz	230/400	230/400	230/400	230/400	230/400	230/400	230/400	230/400	230/400	230/400	230/400	230/400
Operating Voltage [V], 60Hz	208/460	208/460	208/460	208/460	208/460	208/460	208/460	208/460	208/460	208/460	208/460	208/460
Current (full load) [Amp], 400V	0,75	0,75	0,75	0,75	0,82	0,82	0,82	0,82	1,46	1,46	1,46	1,46
Current (full load) [Amp], 230V	1,3	1,3	1,3	1,3	1,42	1,42	1,42	1,42	2,53	2,53	2,53	2,53
Motor power [kW], 400V/3ph/50Hz	0,25	0,25	0,25	0,25	0,33	0,33	0,33	0,33	0,66	0,66	0,66	0,66
Lifting speed [m/min]	4	4	2	2	4	4	2	2	4	4	2	2
FEM group	1Am	1Am	1Am	1Am	1Am	1Am	1Am	1Am	1Am	1Am	1Am	1Am
FEM duty cycle [%]	50	50	50	50	50	50	50	50	50	50	50	50
Starts per hour	300	300	300	300	300	300	300	300	300	300	300	300
IP class	IP55	IP55	IP55	IP55	IP55	IP55	IP55	IP55	IP55	IP55	IP55	IP55
Weight Hoist [kg]	18	18	18	18	28	28	28	28	47	47	47	47
Chain type [mm]	4,0x12,2	4,0x12,2	4,0x12,2	4,0x12,2	5,0x15,1	5,0x15,1	5,0x15,1	5,0x15,1	7,1x20,5	7,1x20,5	7,1x20,5	7,1x20,5
Weight Chain/mtr [kg]	0,35	0,35	0,35	0,35	0,53	0,53	0,53	0,53	1,1	1,1	1,1	1,1
Number of brakes	1	2	1	2	1	2	1	2	1	2	1	2
Lifting classification	D8	D8/D8+	D8	D8/D8+	D8	D8/D8+	D8	D8/D8+	D8	D8/D8+	D8	D8/D8+
Control	Direct	Direct	Direct	Direct	Direct	Direct	Direct	Direct	Direct	Direct	Direct	Direct
Noise Level [dBA]	60	60	60	60	60	60	60	60	60	60	60	60

\*All models available in DC (direct control) and LV (Low Voltage control); example of modelcode: PAE-500DC-00XX and PAE-500LV-00XX



## 1. GENERAL INFORMATION

**Attention:** All users must read these operating instructions carefully prior to the initial operation. These instructions are intended to acquaint the user with the hoist and enable him to use it to the full extent of its intended capabilities.

The operating instructions contain important information on how to handle the hoist in a safe, correct and economic way. Acting in accordance with these instructions helps to avoid dangers, reduce repair costs and downtime and to increase the reliability and lifetime of the hoist.

Anyone involved in doing any of the following work with the hoist must read the operating instructions and act accordingly:

- Operation, including preparation, trouble shooting and cleaning
- Maintenance, inspection, repair
- Transport

Apart from the operating instructions and the accident prevention act valid for the respective country and area where the hoist is used, also the commonly accepted regulations for safe and professional work must be adhered to.

The user is responsible for the proper and professional instruction of the operating personnel.

Every unit leaving the factory is furnished with a test certificate that shows the serial number of the hoist. This certificate has to be filed together with the inspection manual.

The continuous sound level at the place of work is equal to <70 dB. The measures were taken at a distance of 1 m from the hoist at 9 positions in accordance with DIN 45635, precision class 2.

## 2. CORRECT OPERATION

### Lifting capacity

The PROLYFT electric chain hoist series AETOS has been designed to lift and lower loads up to the rated capacity. The lifting capacity indicated on the hoist is the maximum safe working load which must not be exceeded.

### Danger zones

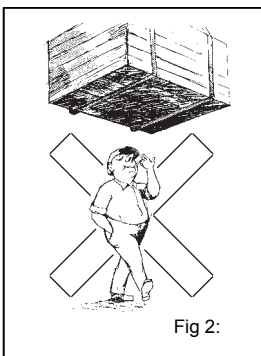

Fig 2:

- Do not allow personnel to pass under a suspended load (see Fig. 2).
- After lifting or tensioning, a load must not be left unattended for a longer period of time.
- Start moving the load only after it has been attached correctly and all personnel are clear of the danger zone.

### Suitable for entertainment use

The PROLYFT electric chain hoist series AETOS are specially designed for use in the Entertainment industry. The hoists are standard configured for **motor down** use. The multi layer disentangle plate will guide the chain to get in and out of the hoist and reduce the risk of blocking. The chain bag bracket is designed to guide the chain in to the chain bag properly.

When the hoist is used in a **motor up** situation the chain bag bracket will swivel to the right position without any adaptations. We recommend to rotate the covers with handgrips 180 degrees when the hoists are used **motor up**.

### Lifting or suspending loads over people

The PROLYFT electric chain hoist series AETOS has been designed for use in the Entertainment Industry. In the Entertainment Industry loads are often suspended or lifted over people.

The lifting capacity as printed on the nameplate of the AETOS hoists is for those situations where the load is not lifted or suspended above people. See chapter 10 of this manual for an explanation of the extra measures needed when lifting or suspending above people.

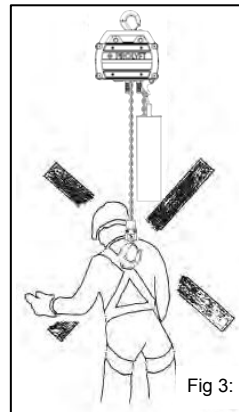

Fig 3:

### Attaching the hoist

The operator must ensure that the hoist is attached in a manner that does not expose himself or other personnel to danger by the hoist, the chain(s) or the load.

### Temperature range

The units can be operated in ambient temperatures between -10°C and +40°C. Consult the manufacturer in case of extreme working conditions.

**Attention:** At ambient temperatures below 0°C check the brake is not frozen.

### Protection against rain and humidity

The AETOS hoists have a protection class of IP55. The hoist can be used in rainy conditions but **not** in heavy rain. It is recommended to cover the hoists if they need to stay in rainy conditions for a longer period. Suitable rain covers can be ordered from Prolyte.

The cabinet of the chain guide is, due to its position, gathering water when the hoist is used in the rain. The bottom of the cabinet is equipped with drain holes. Drain holes must be checked regularly to avoid them from being blocked by dirt.

Apart from direct water, the hoists need to be protected against high humidity levels. Often caused by temperature changes when hoists are moved from high humidity/temperature environments (indoor event area's) to environments with a much lower temperature (trucks after a load out. We strongly recommend to dry the hoists after



these conditions change, either by air or with a cotton cloth. Flight cases or other type of transport boxes should be opened or equipped with ventilation holes.

### Theoretical service life

The electric chain hoist is classified to group 1Am according to FEM 9.511. Basic principles for the calculation of the theoretical remaining service life are given in BGV D8. When the theoretical remaining service life has been reached, the electric chain hoist should be subjected to a general overhaul (also refer to para 8. Maintenance).

### Regulations

The accident prevention act and/or safety regulations of the respective country for using manual and electric chain hoists must be strictly adhered to:

- Europe:
- Machine Directive 2006/42/EG
- Safety of Machinery NEN 12100:2010
- Germany: BGV D6, BGV D8

Additional regulations are in effect for lifting or suspending loads over people.

Germany: SQ P2

The Netherlands: NPR8020-10

United Kingdom: BS7950-1

### Maintenance/Repair

In order to ensure correct operation, not only the operating instructions, but also the conditions for inspection and maintenance must be complied with. If defects are found or abnormal noise is to be heard stop using the hoist immediately.

**Attention:** Before starting to work on electrical components the power-supply is to be cut off.

## 3. INCORRECT OPERATION

- **Do not** exceed the rated capacity of the hoist.
- **Do not** lift stuck or jammed loads.
- **Do not** shortly and frequently actuate the control switch.
- **Do not** use the hoist without additional measures for the transportation of people, see chapter XX(Fig. 3).
- **Do not** weld on hook and load chain.
- **Do not** use the load chain as a ground connection during welding (Fig. 4).

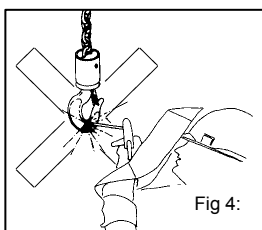

- **Do not** allow any lateral load on either housing or bottom block (Fig. 5).
- **Do not** lift when the load chain is not in a straight line between suspension bracket and hook.
- **Do not** use the load chain for lashing purposes (slings) (Fig. 6).
- **Do not** knot or shorten the load chain by using bolts, screws, screw drivers or other devices (Fig. 7).

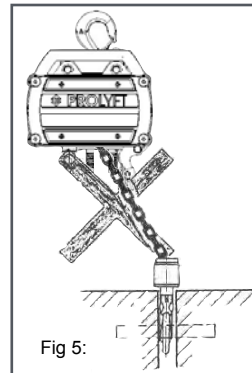

Fig 5:

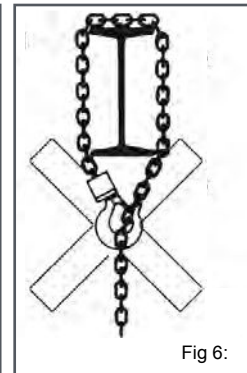

Fig 6:

- **Do not** repair chains installed in the hoist.
- **Do not** remove the safety latch from the load hook (Fig. 8).

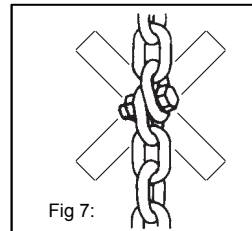

Fig 7:

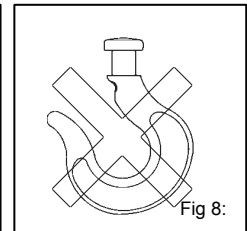

Fig 8:

- **Do not** use the chain end stop as an operational limit device.
- **Do not** throw the hoist down. Always place it properly on the ground or in a flight-case.
- **Do not** operate the hoist in a potentially explosive atmosphere.
- **Do not** modify the hoist except for modifications available through PROLYFT.
- **Do not** drop any load into the loose chain. Risk of chain break!
- **Do not** attach the load to the tip of the hook (Fig. 14). The load must always be seated in the saddle of the hook. This also applies to the suspension hook.
- **Do not** attach more than one load lifting attachment to the load hook of the hoist.
- The bottom blocks are provided with swivel hooks supported by axial bearings. When turning a lifted load the load chain **must not** rotate in any circumstances.

## 4. ASSEMBLY

### 4.1. INSPECTION BEFORE ASSEMBLY

- Check for transport damage.
- Check for completeness.
- Check that the capacity indication on hoist and hook block match.
- Check the proper power supply voltage setting

### 4.2. ELECTRIC CHAIN HOIST WITH SWIVELING HOOK (Standard version)

The standard version of the PROLYFT electric chain hoist, AETOS series, is provided with a swiveling hook assembly. The swiveling hook assembly is connected with the housing of the chain hoist by means of two pins. Make sure that the load hook, irrespective of the reeving, is always positioned vertically under the



swiveling hook suspension (see Fig. 9).

On single strand units, the swiveling hook assembly is installed with the long side to the right, on dual strand units with the long side to the left (see Fig. 9).

**Attention:** Always fit the lock washers after installation of the swiveling hook assembly. Replace the lock washers after every removal.

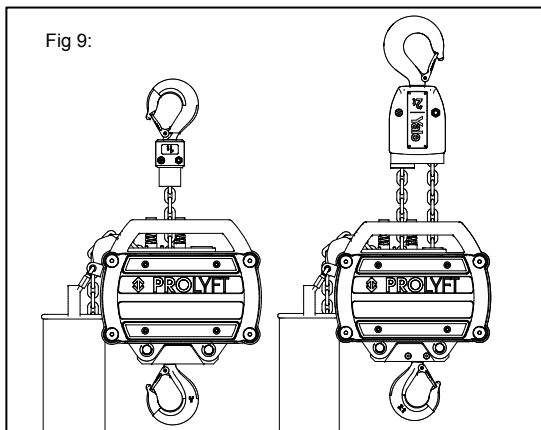

#### 4.2. ELECTRIC CHAIN HOIST WITH SUSPENSION BRACKET (Optional)

Optional the PROLYFT electric chain hoist, AETOS series, can be equipped with a suspension bracket. The suspension bracket is connected with the housing of the chain hoist by means of two bolts. Make sure that the load hook, irrespective of the reeving, is always positioned vertically under the suspension bracket (see Fig. 10).

On single strand units, the suspension bracket is installed with the long side to the right, on dual strand units with the long side to the left (see Fig. 10).

**Attention:** Always fit the lock washers after installation of the suspension bracket. Replace the lock washers after every removal.

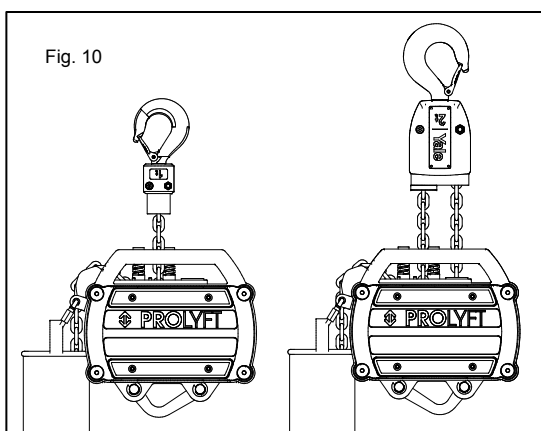

#### 4.3. ELECTRICAL CONNECTION

##### **Attention!**

**Work at electrical installations may be carried out by electrical experts only. The local regulations have to be strictly observed, e.g. EN 60204-32/VDE 0113.**

##### **Preparation**

- Before beginning to work on electrical components the hoist must be disconnected from power.
- Before connecting the chain hoist ensure that the voltage setting of the hoist matches the local supply specifications. All AETOS hoist are standard set to 400V/3phase/50Hz.
- Wiring diagrams are included with the hoist.

##### **Mains supply connection 3 phases**

- All AETOS hoist are standard supplied with a red 16Amp/400V 4 pin connector for the mains supply.
- If the standard connector is removed ensure the following: The mains supply cable must be an insulated cable with 4 flexible leads. The ground (earth) lead must be longer than the live leads. The cross-section should be mm. 1,5 mm<sup>2</sup>, the cable length should be max. 50 m.
- For the fusing of the various models see the table on page 4.
- Cable ends have to be provided with end sleeves.

##### **Connecting to the power supply**

- The mains supply cable must be connected to the electric chain hoist before it is connected to the mains supply.

##### **Direction of rotation**

- Check the motor's direction of rotation.
- The wiring diagram included has been drawn for a normal, clock wise rotating installation. Should the user's mains supply not fulfill these requirements, e.g. the hoist lowers when lift is selected (or vice versa), switch the unit OFF immediately and exchange two of the three phase connections in the power supply.
- **Under no circumstances** may the wiring in the pendant control or the extension cable between the control and the hoist be tampered with, to avoid future operation mistakes when using the control or the extension cable with other hoists.

#### 4.4. DIRECT CONTROLLED HOISTS

- With Direct controlled hoists the hoist will lift or lower "direct" after switching on - or connecting the mains supply.
- When the phases of the mains supply rotate clockwise, the hoist will lift. The hoist will lower when the phases of the mains supply rotate anti-clockwise.
- The order of the phases is switched in the pendant control.
- UP and DOWN buttons on the pendant control must have a "dead man" functionality. Releasing the button will switch off the power.
- Switching on the mains supply will release the brake, independent from the rotation of the mains supply.
- Pressing the E-stop button on the pendant control MUST always switch off the mains supply.
- It is not ALLOWED to operate hoists without having an E-stop button in the mains supply circuit.
- **Never** connect a "direct control" hoist to the mains supply without any (pendant) control. The hoist will start to run!



#### 4.5. LOW VOLTAGE CONTROLLED HOISTS

- With Low Voltage controlled hoists the mains supply is connected to a reversing contactor inside the hoist. Connecting the hoist to the mains supply will not cause lifting or lowering of the hoist.
- A separate connector is provided on the hoist (Yellow 16Amp/115V/4pin female) to connect a pendant control.
- This pendant control will either close the circuit inside the hoist for lifting, when the UP button is pressed or the circuit inside the hoist for lowering when the DOWN button is pressed.
- Pressing the UP or DOWN button on the pendant control, closing the lifting or lowering circuit in the hoist, will release the brake.
- UP and DOWN buttons on the pendant control must have a “dead man” functionality. Releasing the button will open the circuit.
- The mains supply should always have clockwise rotating phases.
- Pressing the E-stop button on the pendant control MUST always switch off the mains supply.
- It is NOT ALLOWED to have E-stops on Low Voltage pendant controls that only open the circuit for lowering or lifting.
- It is not ALLOWED to operate hoists without having an E-stop button in the mains supply circuit.

#### 4.6. ADDING CHAIN AND CHAIN END STOPS

- See chapter 8.6.
- Each hoist comes with a plastic tool inserted in the chain guide, the chain input is always on the side of the chain bag bracket. Connect this tool to one end of the chain and run the hoist in the UP direction. The hoist will pull the chain through the load wheel.
- Make sure the welds of each standing chain link are on the outside of the chain, facing away from the load sheave.
- Remove the chain insert tool from the chain and connect first a foam stopper and second the hook to this end of the chain, the “active” side.
- Put first a foam stopper and second the foam stop washer over the “dead” end of the chain. Place the chain end stop behind the washer. Distance from top of foam stopper, over washer end chain end stop, to the end of the chain must be 60cm for all models.
- Connect the dead end of the chain to the bolt on the chain bag bracket.

#### 4.7. CHAIN BAGS

Only use chain bags suitable for the total length of the chain.

Use only certified quick links to connected the chain bag to the bracket.

When using the hoist in the motor UP position the chain bag bracket will position the chain bag properly underneath the chain output.

Make sure only gravity is needed to guide the chain into the chain bag.

#### 4.8. CIRCUIT DIAGRAM

See on the next page the figures for the circuit diagram.

Fig 11. Electrical drawing: Direct Control

Fig 12. Electrical drawing: Low Voltage Control

#### MOTOR DATA

Model	Operating Voltage	P [kW]	n [1/min]	Kind of connection	In [A] 400V	In [A] 230V	cos φ	FEM Class	ED [%]	Start per hour	Protection degree
PAE-250DC/LV	230/400V, 50hz 208/460V, 60Hz	0,25	1500	Y	0,75	1,3	0,99	1Am	50	300	IP55
PAE-500DC/LV	230/400V, 50hz 208/460V, 60Hz	0,33	1500	Y	0,82	1,42	0,99	1Am	50	300	IP55
PAE-1000DC/LV Table 2	230/400V, 50hz 208/460V, 60Hz	0,66	1500	Y	1,46	2,53	0,99	1Am	50	300	IP55



Fig. 11: Direct Control

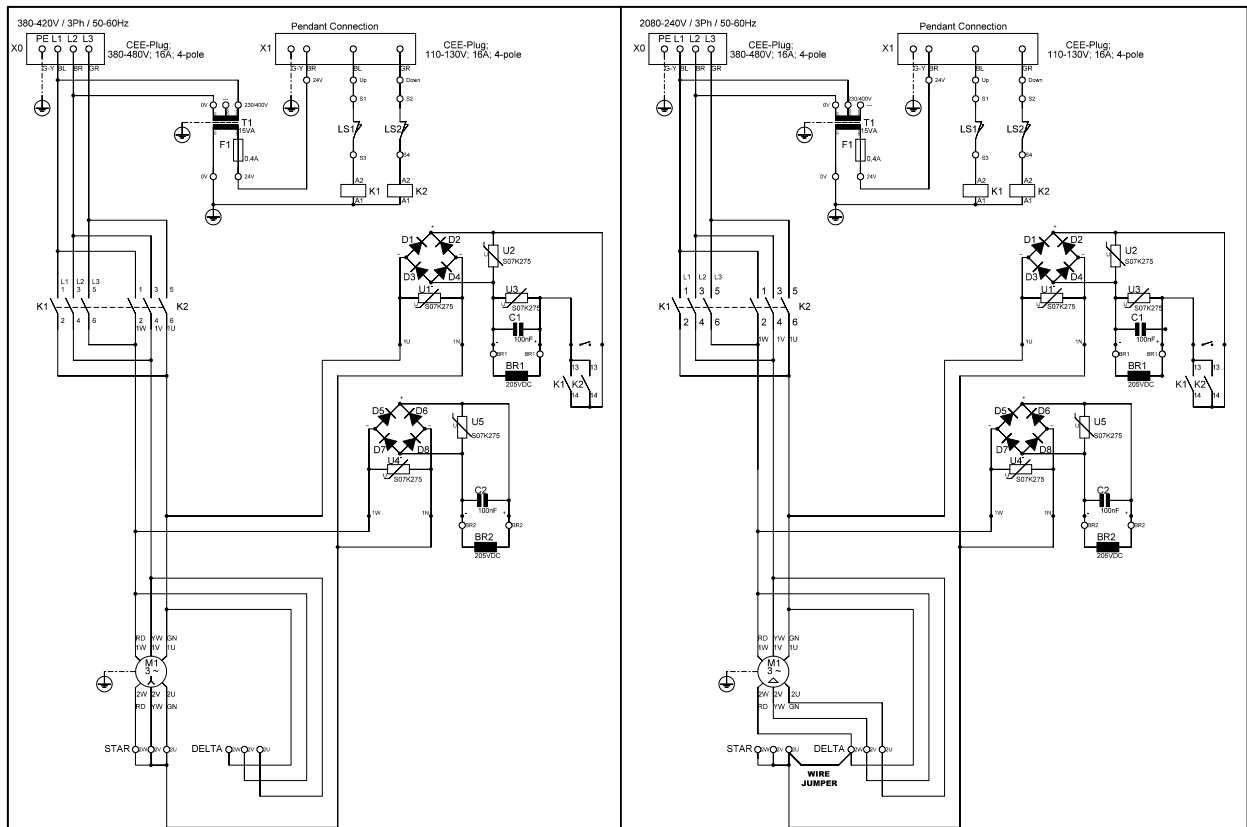
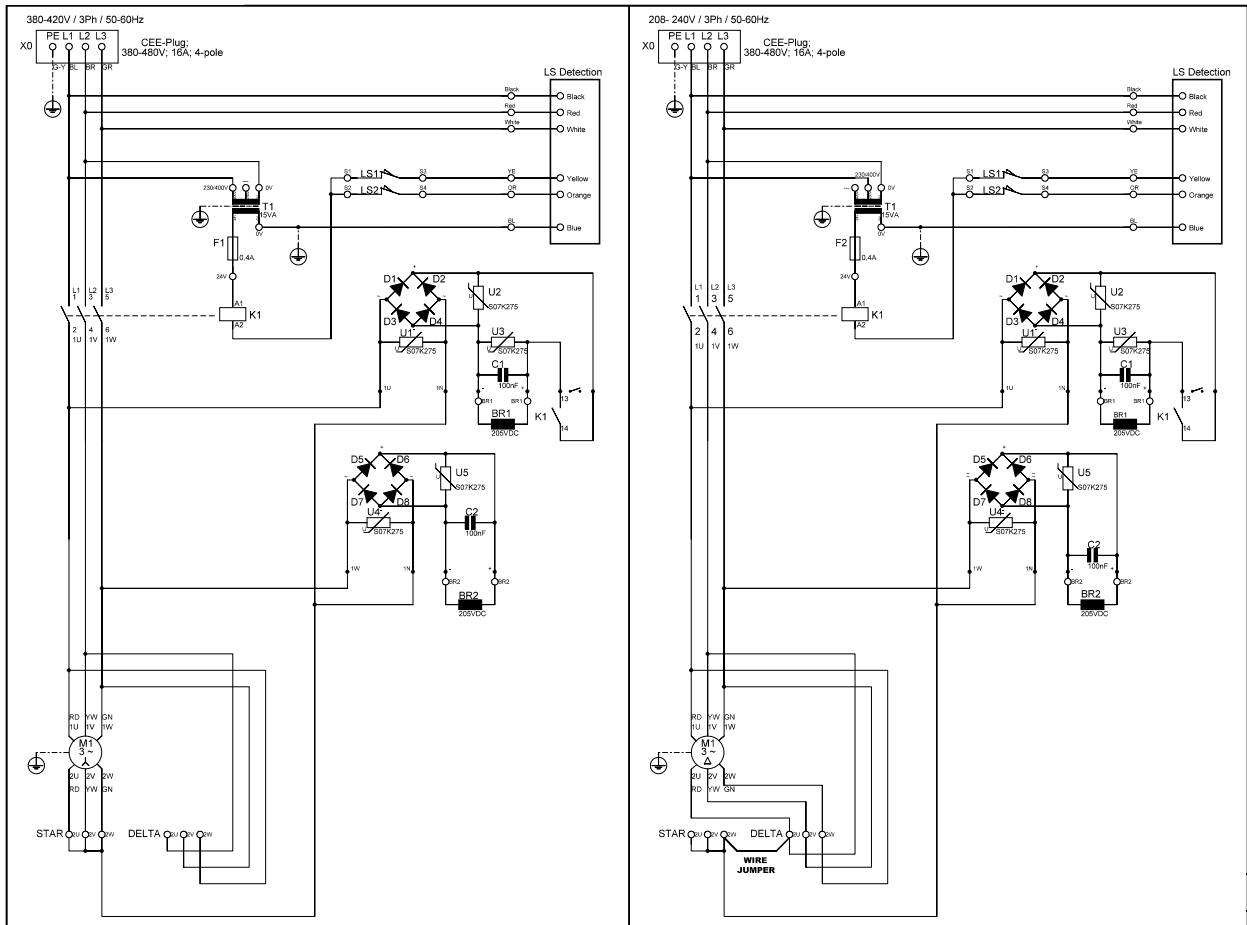



## 5. FUNCTIONAL CHECK BEFORE EVERY INSTALL

Prior to initial operation of the hoist lubricate the load chain when it is not under load (see page 13).

Before the hoist is put into regular service, the following additional inspections must be made:

- Are all screwed connections on the hoist tight and are all locking devices in place and secure?
- Is the chain drive correctly reeved?
- Is the chain bag bracket fitted correctly. It should be able to swivel?
- The chain end stop must be correctly fitted to the loose end of the load chain.
- The dead-end of the chain must be correctly fitted to the dead-end of chain connection on the chain bag bracket.
- Has the chain bag the right capacity?
- Is the chain bag fitted correctly to the chain bag bracket
- All units equipped with two or more chain strands should be inspected before initial operation for twisted or kinked chains. The chains of 2-strand/double reeved hoists may e.g. be twisted if the hook block is rolled over.
- Check the function of the limit switches by running the buffers of the chain end stop resp. hook block against the limit switch under neath the housing. The lifting resp. lowering operation must be stopped immediately.
- Check the brake function when lifting and lowering.

## 6. COMMISSIONING

### Inspection before each initial operation

Each hoist must be inspected prior to EACH initial operation by a competent person and any failures be removed. The inspection is visual and functional. These inspections have to assure that the hoist is safe and has not been damaged by incorrect transport or storage. Inspections should be made by suitably trained personnel. Inspections are instigated by the user or operating company.

\*\*In the Entertainment industry hoists are often moved from one position or venue, transported and installed at another position or venue. After every "re-installation of a hoist it MUST be inspected as with an initial installation as described above. Inspections are always instigated by the user or operating company.

### Inspection by an expert

If the hoist is used with an unguided load with a capacity of at least 1000 kg, or when multiple hoists are lifting a single object the lifting installation has to be inspected and approved by an expert before initial operation. This inspection has to be registered in the inspection logbook. The inspection by the expert has to be instigated by the operating company.

## 7. OPERATION / USE

### Operator skills

Operators delegated to install, service or independently operate the hoist must have had suitable training and be competent.

Operators are to be specifically nominated by the company and must be familiar with all relevant safety regulations of the country of use.

### Visual inspection before starting work

Before starting work inspect the hoist, chains and all load bearing components every time for visual defects. Furthermore test the brake and make sure that the load and hoist are correctly attached by carrying out a short work cycle of lifting and lowering. Selection and calculation of the proper suspension point and beam construction are the responsibility of the operating company.

### Inspection of load chain

Inspect the chain for sufficient lubrication and visually check for external defects, deformations, superficial cracks, wear or signs of corrosion.

### Inspection of chain end stop

The chain end stop must be connected to the dead (idle) end of the chain strand.

### Inspection of chain reeving

All units with two or more chain strands should be inspected prior to initial operation for twisted or kinked chains. The chains of 2-strand hoists may be twisted if the hook block was rolled over (Fig. 13).

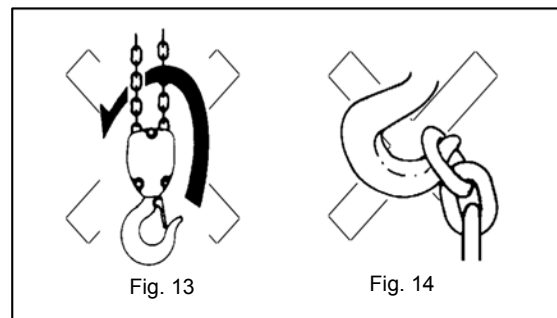

The load chain has to be installed according to illustration (Fig. 15). Hereby the welds on the standing links must face away from the load sheave.

### Inspecting the hooks

Check the load hook and the suspension hook for deformations, cracks, damages, abrasion and signs of corrosion.

### Attaching the load

Attach the load to the hoist using only approved and certified slings or lashing devices. Never use the load chain as sling chain. The load must always be seated in the saddle of the hook (Fig 14). Never attach the load to the tip of the hook. Two parts of a bridles of slings or steels must not exceed an angle of 45 degrees. Use a

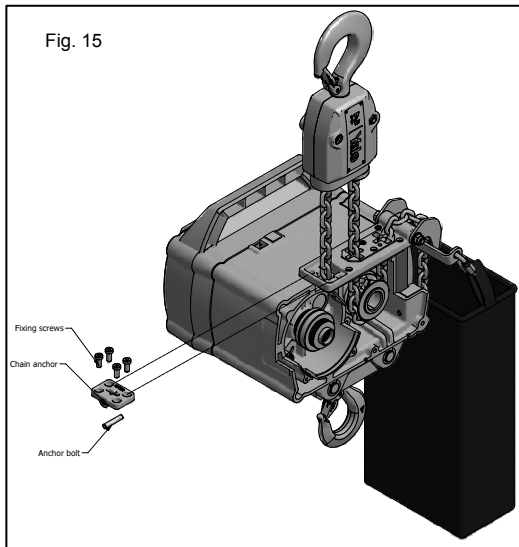

shackle to attach the bridle. Do not remove the safety latch from the load hook. Always check the attachment of the load after the load has “landed”.

#### Lifting/lowering the load

- Never lift a load without direct visual contact with the load.
- The load is lifted by depressing the UP-button, it is lowered by depressing the DOWN-button.
- For hoists with two speeds: The first stage of button depression activates the slow speed, further depression activates the faster speed. In order to raise the load, always use the lowest available lifting speed. The chain must be loaded at this speed and may not lie slack on the floor. The slow speed may only be used for short distances.
- The chain end stop may not be used as operational limit switch.
- Always follow the instructions in the manual of the operating /control device.

#### Emergency stop

All movement can be immediately halted by depressing the red, mushroom shaped button on the pendant control.

**Attention:** Operating the red emergency button does NOT ALWAYS automatically disconnect the mains supply to the hoist. To release the emergency stop, rotate the button in a clockwise direction.

#### End limit switch

This hoist is provided with an end limit switch for the lowest and highest hook position as standard. This limit switch is a safety device and may not be used as operational limiting device.

## 8. SERVICE

### 8.1. GENERAL

- Service and inspections may only be carried out by a competent person.
- The inspection must determine that all safety devices

are present and fully operational and covers the condition of the hoist, lifting gear, accessories and supporting constructions.

- The service intervals and inspections noted are for normal working conditions. Adverse working conditions, e.g. heat, high humidity, or chemical environments, and regular transportation can dictate shorter periods.
- The PROLYFT chainhoist AETOS series conform to FEM group 1Am in accordance with FEM 9.511. This results in a theoretical service lifetime of 800 operating hours under full load.
- This is equivalent to minimum 10 years under normal operating conditions. After this period the hoist requires a general overhaul. Further information is contained in BGV D6 resp. FEM 9.755.
- Attention: Maintenance work requires subsequent function testing with nominal load.

### 8.2. PROLYFT SERVICE PROGRAM / LIFETIME WARRANTY

#### Initial Certificate

- All PROLYFT hoist are provided with a test certificate, describing the hoist and showing the results of the load test. The graph of the load test shows a minimum lifting capacity of 125% of the nominal load.
- All PROLYFT hoist are equipped with a RFID tag with a unique number. The number of the tag refers to the record of the hoist and the result of the load test in the PROLYFT ServiceBase.

#### Registration

- After purchasing the hoist go to the website “service.prolyft.com” to register your hoist.
- After registering your hoist you will have access to all recorded information, certificates, history and load tests connected to your hoist.
- By registering your hoist you get access to the Lifetime Warranty program.

#### Yearly inspection and re-certification

- Every owner of registered hoists will receive an automatic reminder for the yearly inspection and re-certification of the hoist.
- The yearly inspection and re-certification can be done at any PROLYFT Service Point as you can find on the back of this manual or on the website “service.prolyft.com”
- The yearly inspection and re-certification of the hoist guarantees a full visual check of the hoist and the chain, a brake test, and a load test.
- After passing the inspection a new certificate proving the quality of the hoist, including a graph of the load test will be handed over.
- A yearly certified hoist will keep Lifetime Warranty

### 8.3. DAILY CHECKS

- Visually check the pendant control switch and cable for damage.
- Function test of brake.
- Function test of end limit switch.
- Function test of lifting / lowering.



**8.4. INSPECTION AND MAINTENANCE CHECKLIST**

- Serial number: \_\_\_\_\_
- Date: \_\_\_\_\_
- Name of inspector \_\_\_\_\_

Inspection and Maintenance		Initial checks			Periodical Checks		
		During commissioning	After 50 operating hours	After 200 operating hours	Daily	After 200 operating hours	Annually
Chain bag	Inspect chainbag for proper mounting, size, and presence of rips and tears	*	*	*	*	*	*
Nameplates, decals, warning labels	Missing, damaged or illegible			*			*
RFID tag	Missing, damaged or not readable			*			*
Operating controls	Any deficiency causing improper operation. Check operation of hoist with no load present (up, down, abnormal noises)	*	*	*	*	*	*
Function test of limit switches	Any deficiency causing improper operation. Press them manually to check functionality.	*	*	*	*	*	*
Brake mechanism	Slipping, excessive drift, glazing, contamination or excessive wear. Brake gap	*	*	*	*	*	*
Hooks	Excessive throat opening, damaged latch, chemical damage, worn hook bearing, cracks.	*	*	*	*	*	*
Suspension lugs (when used)	Cracks, excessive wear, stretch	*	*	*	*	*	*
Chain	Inadequate lubrication, excessive wear, stretch, cracked- damaged or twisted links, corrosion or foreign substance	*	*	*	*	*	*
Double reeving (if configured)	Twisting, damage or wear on hook load wheel	*	*	*	*	*	*
Pins, Bearings, Bushing shafts, Couplings	Excessive wear, corrosion, cracks, distortion		*	*			*
Nuts, bolts, Rivets	Looseness, stripped and damaged threads, corrosion, locking		*	*			*
Sheaves	Distortion, cracks, excessive wear, build up of foreign substances			*			*
Housing, Load block	Distortion, cracks, excessive wear, build up of foreign substances		*	*		*	*
Wiring, terminals, grommets, strain relief	Fraying, defective insulation, correct mounting, grounding			*		*	*
Circuit board, contactor, transformer	Loose connections, burned or pitted contacts			*			*
Drain holes	Clear from dirt	*	*	*	*	*	*
Seals and gaskets	Good alignment, leakage			*		*	*
Motor	Visual inspection for signs of wear, deterioration, improper operation, excessive heat.			*			*
Slip clutch	Correct slippage level and load holding level	*	*	*			*
Additional remarks							

Table 3



### 8.5. REGULAR INSPECTIONS, SERVICE AND TESTING

According to prevailing national/international occupational safety and health regulations, hoisting equipment must be inspected at least annually by a competent person. Adverse working conditions may dictate shorter inspection periods.

The commissioning and inspection details can be noted on the test certificate delivered with the hoist or on page 13 of this manual. Repairs may only be carried out by PROLYFT Service Points that use original PROLYFT spare parts.

The inspection must determine that all safety devices are present and fully operational and cover the condition of the hoist, lifting gear, accessories and supporting constructions.

If required by the Occupational Health and Safety Organization, the results of the adequate inspections and competent performance of repairs have to be substantiated. If the electric hoist (with capacity of 1 t and up) is installed in a carriage, or if the load is moved in one or several directions, the installation is considered as crane and inspections have to be carried out in accordance with BGV D6-Cranes.

### 8.6. LOAD CHAIN

The load chains are case-hardened and carry the designations 4x 12,2 DAT, 5x 15,1 DAT and 7,1 x20,5 DAT.

The AETOS electric hoists are specially designed to use this type of chain. For this reason only chains that have been approved by the manufacturer may be used in the AETOS hoists.

#### Lubricating the load chain

The load chain is to be lubricated before initial operation and every month, however, latest after 50 operating hours. Adverse working conditions, e.g. excessive dust or continued heavy duty can dictate shorter periods between lubrication.

- Before the chain is lubricated it must be cleaned. Flame cleaning is forbidden. Use only cleansing methods and agents that do not corrode the chain material. Avoid cleansing methods that can lead to hydrogen brittleness, e.g. spraying or dipping chain in caustic solvents. Also avoid surface treatments that can hide cracks and flaws or other surface damage.
- The chain must be lubricated in a no-load condition so that lubricant can enter between the links, e.g. by dipping in oil.
- Either motor oil of the viscosity 100, e.g. Shell Tonna T68 or Rocol DRY PTFE Spray can be used to lubricate the chain. For very dusty applications use a dry lubricant.

#### Inspecting the load chain for wear

Load chains must be inspected every 3 months or the latest after 200 operating hours.

Visually inspect the chain over its full length for deformation, cracks, flaws, elongation, wear or corrosive pitting.

Link chains must be replaced when the nominal thickness  $d$  on any part of the chain has been reduced by more than 10% or when the pitch  $t$  is elongated by more than 5% or over 11 pitches ( $11 \times t$ ) by 2%. Nominal dimensions and wear limits are shown in the following table 2. Chains that do not fulfill all requirements must be replaced immediately.

Link chains A= 4 x 12,2 DAT / B = 5 x 15,1 DAT / C = 7,1 x 20,5 DAT

Inspection	Dim.	Nominal Value [mm]			Wear Limit [mm]		
		A	B	C	A	B	C
Length over 11 pitches	$11 \times t$	134,2	166,1	225,5	136,9	169,4	230,0
Length of 1 pitch	$t$	12,2	15,1	20,5	12,8	15,9	21,5
Diameter	$d$	4	5	7,1	-	-	-
Mean thickness	$\frac{d_1 + d_2}{2}$	4	5	7,1	3,6	4,5	6,4

Table 4

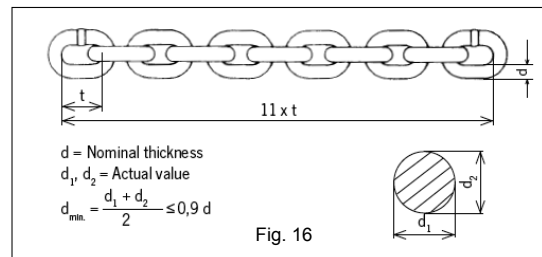

### Replace the load chain

#### 1-strand design

- Disassemble chain hook.
- Unscrew both cylinder screws and separate the housing halves. Remove the foam stopper.
- Remove the dead of the chain from the chain bag bracket. Remove the chain end stop, by removing the 2 screws, remove the foam stop washer and remove the foam stopper.
- Fitting the new chain
- Cut the second to last link open on the loose end of the load chain to form a C. Remove the last link and connect the new chain. The new chain must be fitted so that the welds on the standing links face towards the chain guide and away from the load sheave. Operate the hoist in the lowering direction (DOWN-button) to feed the chain through the hoist.
- Fitting chain hook and chain end stop.
- Slide the foam stoppers over the loose ends of the load chain and refit chain hook, foam stop washer and chain end stop. The chain end stop must be fitted so that the length over foam stopper and chain end stop towards the end of the chain is 60cm.
- Connect dead end of the chain to the chain bag bracket.
- Attention: Install new hex. nuts with clamping part.
- Before initial operation lubricate the unloaded chain and test all hoist functions under no-load condition.



### 2-strand design

- Remove the chain anchor bolt.
- The chain anchor bolt is situated next to the disentangle plate. First unscrew the four cylinder screws of the chain anchor. Then tap out the anchor bolt with a drift.
- Attention: Do not damage anchor bolt or bore.
- Pull the load chain through the chain hook and remove the chain end stop.
- Fitting the new chain
- Cut the second to last link open on the loose end of the load chain to form a C. Remove the last link and connect the new chain. The new chain must be fitted so that the welds on the standing links face towards the chain guide and away from the load sheave. Operate the hoist in the lowering direction (DOWN-button) to feed the chain through the hoist.
- Guide the new chain through the double reeved hook by pulling the old chain manually through the hook block.
- See the 1-strand instructions for positioning the end-stops.

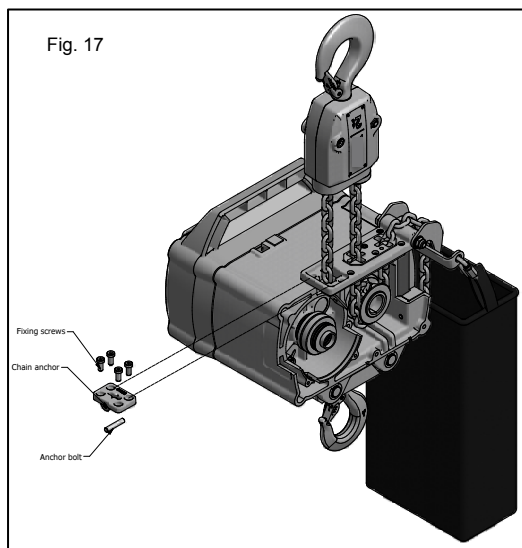

### Fitting the chain anchor bolt

Inspect the chain anchor bolt (Fig. 17) for flaws, cracks or burrs. Enter the last link of the new load chain end into the slot in the underside of the chain anchor.

Attention: The chain must not be twisted.

Now enter the chain anchor bolt through the side bore.

Attention: Move the last chain link back and forth while entering the chain anchor bolt to ensure that the chain is not trapped or damaged by the anchor bolt.

Finally the chain anchor is screwed with the housing again.

Fastening torque for the locking screws: M6 - 10 Nm / MS 25 Nm

Functional fixed after 60 minutes.

Curing time at room temperature 24 hours.

Attention: Screws should be used only one time.

### Functional test

All units with two or more chain strands must be inspected before every operation for twisted or kinked chains. Chains on 2-strand units may become twisted if the bottom block is rolled over. If a strand is twisted disconnect it from the hoist and re-thread it correctly. In some cases it may be necessary to remove the last link. Before initial operation lubricate the unloaded chain and test all hoist functions under a no-load condition.

### 8.7. MAINTENANCE LOAD HOOK

Inspect the hooks for deformation, damage, surface cracks, wear and signs of corrosion as required but at least annually. Adverse working conditions may dictate shorter periods. Hooks that do not fulfill all requirements must be replaced immediately. Welding on hooks to compensate for wear or damage is not permissible. Hooks must be replaced when the mouth of the hook has opened more than 10% (Fig. 15) or the nominal value of other dimensions has decreased by 5% due to wear. Nominal dimensions and wear limits are shown in the following table.

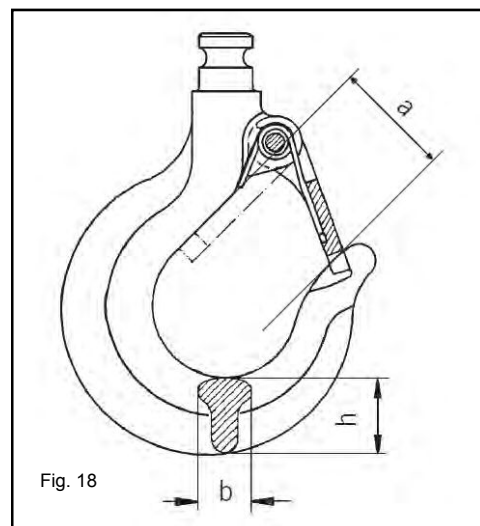

Inspection		Hook width	Hook height	Hook opening
Dim.		b	h	a
PAE-250 housing hook	Nominal size [mm]	15,0	22,1	38,0
PAE-250 housing hook	Minimum size [mm]	14,2	21,0	41,8
PAE-250 chain hook	Nominal size [mm]	14,0	17,0	24,0
PAE-250 chain hook	Minimum size [mm]	13,3	16,2	26,4
PAE-500	Nominal size [mm]	15,0	22,1	38,0
PAE-500	Minimum size [mm]	14,2	21,0	41,8
PAE-1000	Nominal size [mm]	22,0	30,0	35,0
PAE-1000	Minimum size [mm]	20,9	28,5	38,5



## 8.8. MAINTENANCE OF OVERLOAD PROTECTION DEVICE

### Overload protection device

The unit is equipped with an overload protection device as standard. This device is factory set to 125% + 15% of the rated capacity and prevents reliably overloading of the hoist during lifting of loads. Adjustment and testing of the overload device may only be carried out by authorized competent persons.

The force-limit factor according to EN 14492-2:2006 is  $\phi_{DAL}=1,35$ . The maximum force occurring when the rated capacity limiter operates will be calculated as:

$$F_{LIM} = (\phi_{DAL} \times m_{RC} + m_H - m_{RC}) \times g$$

$$\phi_{DAL} = 1,35$$

$m_{RC}$  = Rated capacity of the hoist [kg]

$m_H$  = Hoist load [kg]

Hoist load  $m_H$ : Load which includes all the masses of a load equal to the rated capacity of the hoist, the hoist medium and the fixed load lifting attachments, e.g. hooks, grabs, lifting beams etc.

$g$  = Acceleration due to gravity (9,81) [m/s<sup>2</sup>]

Fig. 19



### Adjustment of overload device (Fig. 19)

Attention: The adjustment of the overload device may only be done by authorized, competent personnel.

Attention: During this job the hoist remains operable which can result in danger of injury by rotating parts.

- Loosen the adjusting nut [6] with a pin type face wrench acc. to DIN 3116 in anti-clockwise direction until blocked.

**Attention:** The adjusting nut is secured with a screw securing agent (Loctite® 243). For loosening, it may be necessary to heat up the area of the adjusting nut to max. 80° C using a hot-air blower, for example. Any remainders of the screw securing agent must be completely removed.

Attention: Prior to new adjustment, always use Loctite® 243 again for securing the adjusting nut.

- Turn the adjusting nut in clockwise direction, until the test load is raised. Attention: The max. operating time of the overload device is 60 seconds. Thereafter the unit has to cool down to room temperature [mm. 20 minutes].
- Reassemble in opposite sequence.

## 8.9. MAINTENANCE OF GEARBOX

**The gearbox is practically maintenance-free. Service is therefore reduced to changing the oil or grease.**

The gearbox oil/grease should be changed after every 10 years, however, latest after 800 operating hours (oil volume see table 6).

**Attention:** During oil change the electric power supply must be shut off.

### Oil change PAE-500 and PAE-1000 (Fig. 20A)

Disassemble the gear cover by removing the cylinder screws. Place the hoist horizontally and turn so that the oil can drain from the fill hole into a suitable container (approx. 30 minutes). Replenish the gearbox oil. Finally re-adjust the device with a new gasket.

### Grease change PAE-250 (Fig 20B).

Disassemble the gear cover by removing the cylinder screws. Remove the grease with cleaning paper. Attach the new grease to the transmission with the use of a small grease gun. Finally re-adjust the device with a new gasket.

Model	Volume	Type
PAE-250	20 mL	DGM-EPL-100, grease
PAE-500	0,3 L	FINA GIRAN L320, ISO-VG 320
PAE-1000	0,5 L	FINA GIRAN L320, ISO-VG 320

Table 6

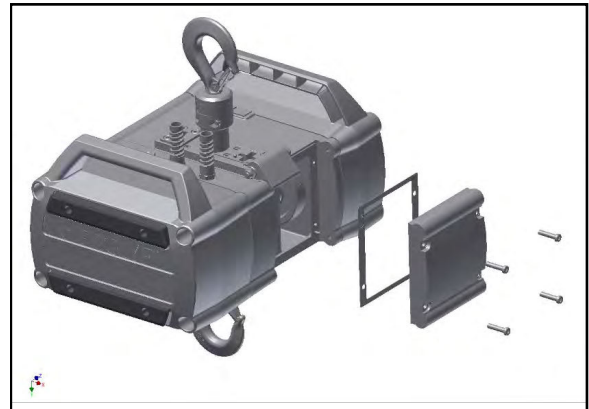
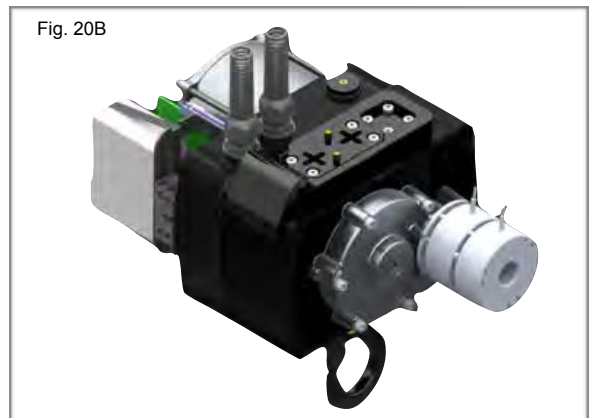

Fig. 20B





## 8.10.MAINTENANCE OF MOTOR

### Motor

Under normal conditions the motor is practically maintenance-free.

### Spring activated disc brake

Service to the motor brake is reduced to checking and adjustment of the nominal brake air gap. The disc brake air gap should be between 0,15 and 0,6 mm. This guarantees short reaction time and low noise emission. When the wear at the brake lining comes down to the point, where the max possible air gap has finally been reached, the brake lining has to be replaced.

Attention: **Do not allow the brake friction pads come into contact with lubricant or similar.**

Attention: **When checking the air gap, the motor must be switched off and the hoist must be unloaded.**

- Measure air gap SLÜ between armature disc and magnet part with feeler gauge.
- Compare measured air gap value with max admissible air gap SLÜ (see table 7).
- If necessary replace rotor with brake lining.

Model	Air gap + 0,1 SLÜ [mm]		Springforce brake (Typ)
	Nenn.	max.	
PAE-250	0,15	0,3	BKF 457-04
PAE-500	0,2	0,4	BKF 457-05
PAE-1000	0,2	0,6	BKF 457-06

Tab. 7

### Replacement of brake rotor with friction lining:

- Loosen the three countersunk socket screws (item 3), lift-off flange
- (item 2) and replace rotor with friction lining (item 1). Reassemble in opposite sequence.
- Finally check the brake function with nominal load in lifting and lowering operation.

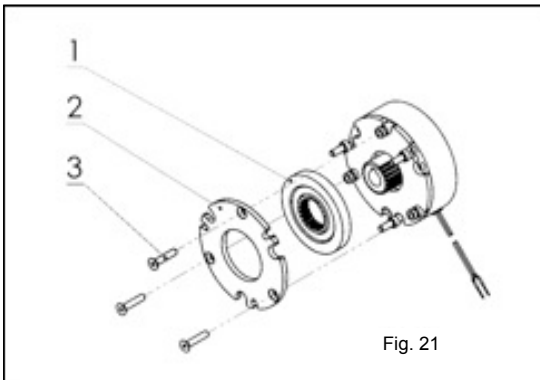

Fig. 21

### Build-up of motor brake:

Attention: **The unit must be de-energized!**

- Disassemble the brake cover (item 3) by loosening the four cylinder screws.
- Loosen the three socket screws of the brake and pull-

Fig. 22

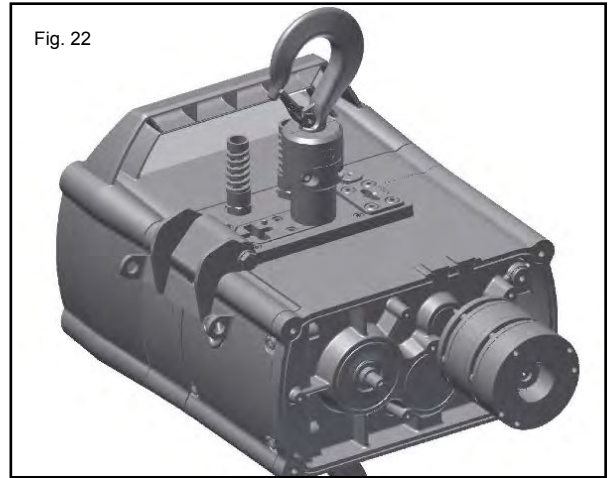

- off the brake. (Disconnect the control cable)
- After replacement of the motor brake, make sure that the function is tested with nominal load.

## 9. ELECTRIC CHAIN HOIST IN GENERAL

In particular check following parts:

- Threaded connections in general
- Check all nuts, screws and locking devices for tightness.
- Chain container
- Ensure the chain container is securely fastened. Check for cracks or wear.
- Suspension bolt
- (Connection between hoist and suspension bracket resp. trolley) Check for cracks or wear. Ensure all safety devices are in place and secure.

## 10. LIFTING OVER PEOPLE

In the entertainment industry lifting over people is daily practice. The European Machine directive demands to make a **risk assessment** when using electrical chain hoists to lift or suspend loads over people. Local regulations may differ but in general they demand the following actions:

- the safety factor must be doubled by either creating a second suspension or reducing the nominal load with 50%.
- a second brake is demanded in some standards.
- full awareness of the lifted load per hoist.
- proper protection against overloading.

Note that the above recommended actions never replace local regulations and the risk assessment.



## 11. EXPLODED VIEW

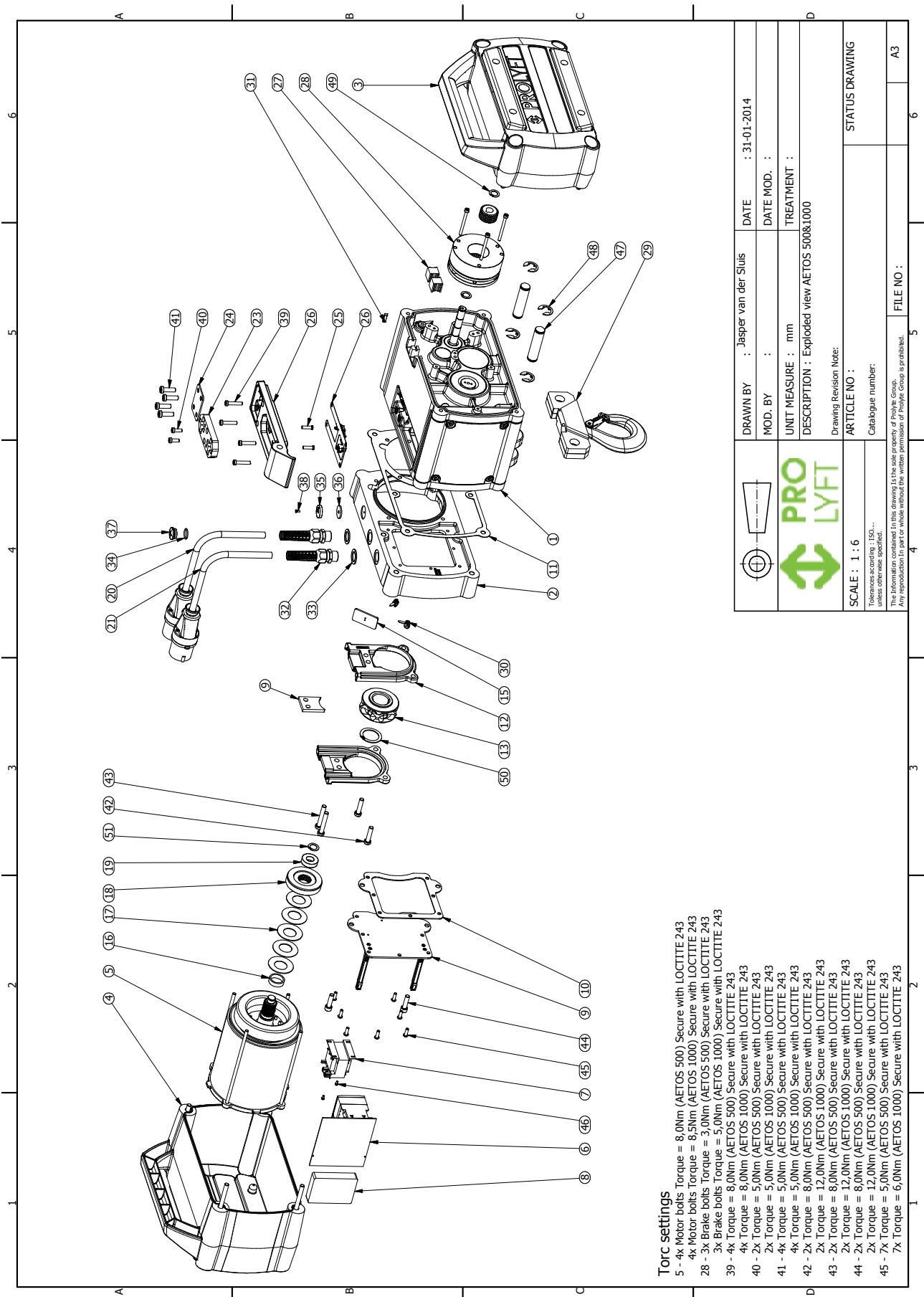

### Torc settings

- 5 - 4x Motor bolts Torque = 8,0Nm (AETOS 500) Secure with LOCTITE 243
- 4x Motor bolts Torque = 6,5Nm (AETOS 1000) Secure with LOCTITE 243
- 28 - 3x Brake bolts Torque = 3,0Nm (AETOS 500) Secure with LOCTITE 243
- 3x Brake bolts Torque = 5,0Nm (AETOS 1000) Secure with LOCTITE 243
- 39 - 4x Torque = 8,0Nm (AETOS 500) Secure with LOCTITE 243
- 4x Torque = 8,0Nm (AETOS 1000) Secure with LOCTITE 243
- 40 - 2x Torque = 5,0Nm (AETOS 500) Secure with LOCTITE 243
- 2x Torque = 5,0Nm (AETOS 1000) Secure with LOCTITE 243
- 41 - 4x Torque = 5,0Nm (AETOS 500) Secure with LOCTITE 243
- 4x Torque = 5,0Nm (AETOS 1000) Secure with LOCTITE 243
- 42 - 2x Torque = 8,0Nm (AETOS 500) Secure with LOCTITE 243
- 2x Torque = 12,0Nm (AETOS 1000) Secure with LOCTITE 243
- 43 - 2x Torque = 8,0Nm (AETOS 500) Secure with LOCTITE 243
- 2x Torque = 12,0Nm (AETOS 1000) Secure with LOCTITE 243
- 44 - 2x Torque = 8,0Nm (AETOS 500) Secure with LOCTITE 243
- 2x Torque = 12,0Nm (AETOS 1000) Secure with LOCTITE 243
- 45 - 7x Torque = 5,0Nm (AETOS 500) Secure with LOCTITE 243
- 7x Torque = 6,0Nm (AETOS 1000) Secure with LOCTITE 243

	DRAWN BY : Jasper van der Sluis	DATE : 31-01-2014
	MOD. BY :	DATE MOD. :
	UNIT MEASURE : mm	TREATMENT :
	DESCRIPTION : Exploded view AETOS 500&1000	
	Drawing Revision Note:	
SCALE : 1 : 6	ARTICLE NO :	STATUS DRAWING
Tolerances according to ISO..... unless otherwise specified.		
The information contained in this drawing is the sole property of Prolyte Group. Any reproduction in part or whole without the written permission of Prolyte Group is prohibited.		
	FILE NO :	A3



# PRO LYFT

# AETOS Range

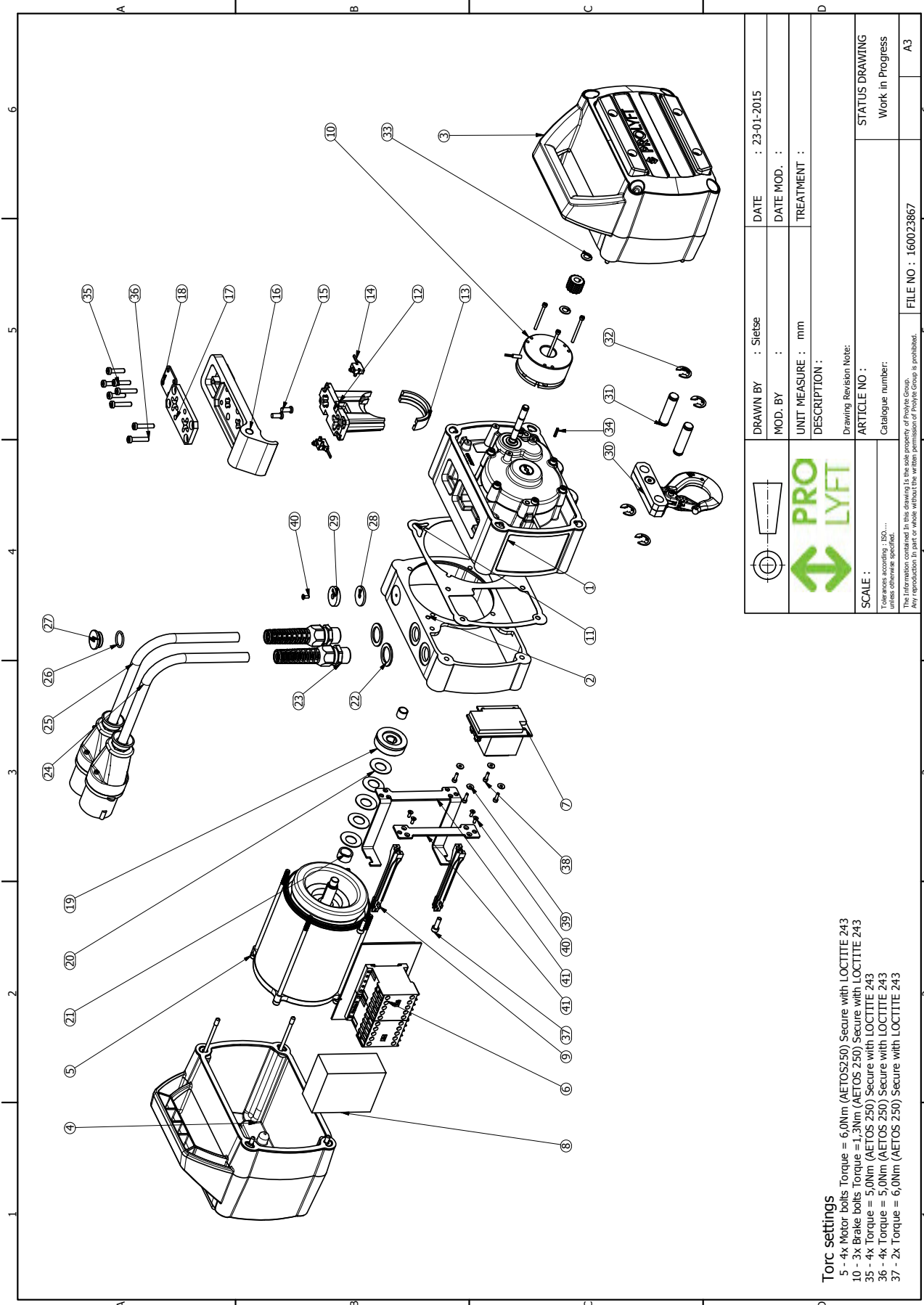

### Torc settings

- 5 - 4x Motor bolts Torque = 6,0Nm (AETOS250) Secure with LOCTITE 243
- 10 - 3x Brake bolts Torque = 1,3Nm (AETOS 250) Secure with LOCTITE 243
- 35 - 4x Torque = 5,0Nm (AETOS 250) Secure with LOCTITE 243
- 36 - 4x Torque = 5,0Nm (AETOS 250) Secure with LOCTITE 243
- 37 - 2x Torque = 6,0Nm (AETOS 250) Secure with LOCTITE 243

	DRAWN BY : Sietse	DATE : 23-01-2015
	MOD. BY :	DATE MOD. :
	UNIT MEASURE : mm	TREATMENT :
	DESCRIPTION :	
	Drawing Revision Note:	
	ARTICLE NO :	STATUS DRAWING
	Catalogue number:	Work in Progress
<small>Tolerances according ISO... unless otherwise specified.</small> <small>The information contained in this drawing is the sole property of Prolyte Group. Any reproduction in part or whole without the written permission of Prolyte Group is prohibited.</small>		FILE NO : 160023867



## 12. SPARE PARTS

Part nr.	Catalog code PAE-250DC	Description
1	PAE-S-671387	GEAR ASSY AETOS 250
2	PAE-S-671383	MOTOR SPACER AETOS 250
3	PAE-S-BC250-01C	BRAKECOVER AETOS 250 COMPLETE
4	PAE-S-MC250-01C	MOTORCOVER AETOS 250 COMPLETE
5	PAE-S-671375	MOTOR ASSY 400-230V 3PH 50-60HZ AETOS 250
6	PAE-S-671434	CONTROL BOARD DC AETOS 250
7	PAE-S-671503	TRANSFORMER BOARD PRI.400-230V SEC.24V
8	PAE-S-671258	LIMIT SWITCH DETECTION 207-400VOLT
9	PAE-S-671195	CONTROL BOARD RETAINER
10	PAE-S-671396	BRAKE BFK457-04 AETOS 250
11	PAE-S-671385	GASKET MOTOR SPACER AETOS 250
12	PAE-S-670994	CHAIN GUIDE BOTTOM AETOS 250
13	PAE-S-670993	CHAIN GUIDE TOP AETOS 250
14	PAE-S-671393	MICRO SWITCH ASSY AETOS 250
15	PAE-S-671426	LIMIT SWITCH ADAPTER AETOS 250
16	PAE-S-671429	DISENTANGLE PLATE AETOS 250
17	PAE-S-671428	DISENTANGLE PLATE INSERT AETOS 250
18	PAE-S-671112	ANCHOR COVER PLATE AETOS 250
19	PAE-S-671052	CLUTCH HUB ASSY AETOS 250
20	PAE-S-9120060	DISC SPRING 28x14,2x0,8 AETOS 250

Part nr.	Catalog code PAE-250DC	Description
21	PAE-S-671041	SPACER BUSH 18x14x10 AETOS 250
22	PAE-S-780537	SEALING DISC FOR M20
23	PAE-S-671145	CABLE GLAND WITH ANTIKINK FITTING
25	PAE-S-671216	ASSEMBLED CONTROL LINE AETOS 250-500-1000
26	PAE-S-671416	O-RING M20
27	PAE-S-671415	BLIND SCREW PLUG M20X1,5
28	PLS-033050011	PLASTIC RING 5Xd 5,3X25X2,5,PL
29	PLT-10-010	TAG LRP125 RFIP,25MM FOR HOIST
30	PAE-S-671380	SUSPENSION HOOK ASSY AETOS 250
31	PAE-S-671036	LOAD PIN AETOS 250
32	PAE-S-9123049	RETAINING RING DIN6799-10-FST
33	PAE-S-9129031	RETAINING RING DIN471-8x0,8
34	PAE-S-9131099	KEY 2x2x14 DIN6885-A
35	PAE-S-9102332	BOLT M5X20 INBUS 8.8 DIN7984
36	PAE-S-9102194	BOLT M5X25 INBUS 8.8 DIN7984
37	PAE-S-9102199	BOLT M5X16 INBUS 8.8 ISO4762
38	PAE-S-9102319	BOLT M3X10 INBUS 8.8 ISO4762
39	PAE-S-9121029	WASHER 3,2X7X,0,5 FLAT ISO7090
40	PAE-S-9104131	BOLT M3X8 INBUS 8.8 C.SUNK ISO10642
41	PAE-S-671459	CONTROL BOARD MOUNTING BRACKET AETOS 250



Part nr.	Catalog code PAE-250LV	Description
1	PAE-S-671387	GEAR ASSY AETOS 250
2	PAE-S-671383	MOTOR SPACER AETOS 250
3	PAE-S-BC250-01C	BRAKECOVER AETOS 250 COMPLETE
4	PAE-S-MC250-01C	MOTORCOVER AETOS 250 COMPLETE
5	PAE-S-671375	MOTOR ASSY 400-230V 3PH 50-60HZ AETOS 250
6	PAE-S-671455	CONTROL BOARD LV AETOS 250
7	PAE-S-671503	TRANSFORMER BOARD PRI.400-230V SEC. 24V
9	PAE-S-671195	CONTROL BOARD RETAINER
10	PAE-S-671396	BRAKE BFK457-04 AETOS 250
11	PAE-S-671385	GASKET MOTOR SPACER AETOS 250
12	PAE-S-670994	CHAIN GUIDE BOTTOM AETOS 250
13	PAE-S-670993	CHAIN GUIDE TOP AETOS 250
14	PAE-S-671393	MICRO SWITCH ASSY AETOS 250
15	PAE-S-671426	LIMIT SWITCH ADAPTER AETOS 250
16	PAE-S-671429	DISENTANGLE PLATE AETOS 250
17	PAE-S-671428	DISENTANGLE PLATE INSERT AETOS 250
18	PAE-S-671112	ANCHOR COVER PLATE AETOS 250
19	PAE-S-671052	CLUTCH HUB ASSY AETOS 250
20	PAE-S-9120060	DISC SPRING 28x14,2x0,8 AETOS 250
21	PAE-S-671041	SPACER BUSH 18x14x10 AETOS 250

Part nr.	Catalog code PAE-250LV	Description
22	PAE-S-780537	SEALING DISC FOR M20
23	PAE-S-671145	CABLE GLAND WITH ANTIKINK FITTING
24	PAE-S-671215	ASSEMBLED CONTROL LINE AETOS 250-500-1000
25	PAE-S-671216	ASSEMBLED POWER LINE AETOS 250-500-1000
28	PLS-033050011	PLASTIC RING 5Xd 5,3X25X2,5,PL
29	PLT-10-010	TAG LRP125 RFIP,25MM FOR HOIST
30	PAE-S-671380	SUSPENSION HOOK ASSY AETOS 250
31	PAE-S-671036	LOAD PIN AETOS 250
32	PAE-S-9123049	RETAINING RING DIN6799-10-FST
33	PAE-S-9129031	RETAINING RING DIN471-8x0,8
34	PAE-S-9131099	KEY 2x2x14 DIN6885-A
35	PAE-S-9102332	BOLT M5X20 INBUS 8.8 DIN7984
36	PAE-S-9102194	BOLT M5X25 INBUS 8.8 DIN7984
37	PAE-S-9102199	BOLT M5X16 INBUS 8.8 ISO4762
38	PAE-S-9102319	BOLT M3X10 INBUS 8.8 ISO4762
39	PAE-S-9121029	WASHER 3,2X7X,0,5 FLAT ISO7090
40	PAE-S-9104131	BOLT M3X8 INBUS 8.8 C.SUNK ISO10642
41	PAE-S-671459	CONTROL BOARD MOUNTING BRACKET AETOS 250



Part nr.	Catalog code PAE-500DC	Description
1	PAE-S-671131	GEAR ASSY AETOS 500
2	PAE-S-671141	MOTOR SPACER AETOS 500
3	PAE-S-BC500-01C+PAE-S-BC500-05	BRAKECOVER AETOS 500 COMPLETE + BRAKECOVER GASKET AETOS 500
4	PAE-S-MC500-01C+PAE-S-MC500-05	MOTORCOVER AETOS 500 COMPLETE + MOTORCOVER GASKET AETOS 500
5	PAE-S-671138	MOTOR ASSY 400-230V, 3PH, 50-60HZ AETOS 500
6	PAE-S-671208	Board Assy. f. DC-Control
7	PAE-S-0061003	TRANSFORMER PRI.400-230V SEC.24V
8	PLA-55-025	LIMIT SWITCH DETECTION 440VOLT AC, 3PHASE
9	PAE-S-671172	CHAIN WHEEL COVER ASSY AETOS 500
10	PAE-S-671136	CHAIN WHEEL COVER SEALING AETOS 500
11	PAE-S-671182	GASKET MOTOR SPACER AETOS 500
12	PAE-S-670823	CHAIN GUIDE HALF AETOS 500
13	PAE-S-670109	LOAD WHEEL 5X15,1 CHAIN
14	PAE-S-671105	CHAIN STRIPPER AETOS 500
15	PAE-S-670356	LIMIT SWITCH WIRE SEAL AETOS 500-1000
16	PAE-S-670126	SPACER BUSH 25X20,3X7,5 AETOS 500
17	PAE-S-9120056	DISC SPRING 40x20,4x1 AETOS 500
18	PAE-S-670075	CLUTCH HUB ASSY AETOS 500
19	PAE-S-9150032	BAL BEARING 6001 DIN625 T1
21	PAE-S-671216	ASSEMBLED POWER LINE AETOS 500-1000
22	PAE-S-671163	DISENTANGLE PLATE AETOS 500
23	PAE-S-671184	DISENTANGLE PLATE INSERT AETOS 500
24	PAE-S-670394	ANCHOR COVER PLATE AETOS 500
25	PAE-S-671134	LIMIT SWITCH ADAPTER AETOS 500
26	PAE-S-671043	MICRO SWITCH ASSY AETOS 500

Part nr.	Catalog code PAE-500DC	Description
27	PAE-S-671194	BLIND PLUG SQUARE BLACK AETOS 500-1000
28	PAE-S-671146	BRAKE BFK457-06 AETOS 500
29	PAE-S-671167	SUSPENSION HOOK ASSY AETOS 500
30	PAE-S-671044	FASTENING STRAP
31	PAE-S-9131096	KEY 4x4x18 DIN 6885-A
32	PAE-S-671145	CABLE GLAND WITH ANTIKINK FITTING
33	PAE-S-780537	SEALING DISC FOR M20
34	PAE-S-9184106	LOCK NUT GMP-GL-M20X1,5
35	PLT-10-010	TAG LRP125 RFI,25MM FOR HOIST
36	PLS-033050011	PLASTIC RING 5Xd 5,3X25X2,5
37	PAE-S-671220	BLIND PLUG
38	PAE-S-9104131	BOLT M3x8 INBUS 8.8 ISO10642
39	PAE-S-9102169	BOLT M6x25 INBUS 8.8 DIN7984
40	PAE-S-9102265	BOLT M6x12 INBUS 8.8 DIN7984
41	PAE-S-9102169	BOLT M6x25 INBUS 8.8 DIN7984
42	PAE-S-9102293	BOLT M6x25 INBUS 8.8 DIN6912
43	PAE-S-9102292	BOLT M6x35 INBUS 8.8 DIN6912
44	PAE-S-9101722	BOLT M6x25 INBUS 8.8 DIN7984 PRECOTE 80
45	PAE-S-9108066	BOLT M6x16 INBUS 10.9 ISK ISO7380 LENS HEAD
46	PAE-S-9101719	BOLT M3x6 INBUS 8.8 DIN 7984
47	PAE-S-670061	LOAD PIN AETOS 500
48	PAE-S-9123038	RETAINING RING DIN6799-12-FST
49	PAE-S-9129005	RETAINING RING DIN471-11x1
50	PAE-S-9129001	RETAINING RING DIN471-25x1,2
51	PAE-S-9129038	RETAINING RING DIN471-12x1



Part nr.	Catalog code PAE-500LV	Description
1	PAE-S-671131	GEAR ASSY AETOS 500
2	PAE-S-671141	MOTOR SPACER AETOS 500
3	PAE-S-BC500-01C+PAE-S-BC500-05	BRAKECOVER AETOS 500 COMPLETE + BRAKECOVER GASKET AETOS 500
4	PAE-S-MC500-01C+PAE-S-MC500-05	MOTORCOVER AETOS 500 COMPLETE + MOTORCOVER GASKET AETOS 500
5	PAE-S-671138	MOTOR ASSY 400-230V, 3PH, 50-60HZ AETOS 500
6	PAE-S-671174	BOARD ASSY. F. LV CONTROL AETOS 500 +1000
7	PAE-S-0061003	TRANSFORMER PRI.400-230V SEC.24V
9	PAE-S-671172	CHAIN WHEEL COVER ASSY AETOS 500
10	PAE-S-671136	CHAIN WHEEL COVER SEALING AETOS 500
11	PAE-S-671182	GASKET MOTOR SPACER AETOS 500
12	PAE-S-670823	CHAIN GUIDE HALF AETOS 500
13	PAE-S-670109	LOAD WHEEL 5X15,1 CHAIN
14	PAE-S-671105	CHAIN STRIPPER AETOS 500
15	PAE-S-670356	LIMIT SWITCH WIRE SEAL AETOS 500-1000
16	PAE-S-670126	SPACER BUSH 25X20,3X7,5 AETOS 500
17	PAE-S-9120056	DISC SPRING 40x20,4x1 AETOS 500
18	PAE-S-670075	CLUTCH HUB ASSY AETOS 500
19	PAE-S-9150032	BAL BEARING 6001 DIN625 T1
20	PAE-S-671215	ASSEMBLED CONTROL LINE AETOS 500 +1000
21	PAE-S-671216	ASSEMBLED POWER LINE AETOS 500-1000
22	PAE-S-671163	DISENTANGLE PLATE AETOS 500
23	PAE-S-671184	DISENTANGLE PLATE INSERT AETOS 500
24	PAE-S-670394	ANCHOR COVER PLATE AETOS 500
25	PAE-S-671134	LIMIT SWITCH ADAPTER AETOS 500
26	PAE-S-671043	MICRO SWITCH ASSY AETOS 500

Part nr.	Catalog code PAE-500LV	Description
27	PAE-S-671194	BLIND PLUG SQUARE BLACK AETOS 500-1000
28	PAE-S-671146	BRAKE BFK457-06 AETOS 500
29	PAE-S-671167	SUSPENSION HOOK ASSY AETOS 500
30	PAE-S-671044	FASTENING STRAP
32	PAE-S-671145	CABLE GLAND WITH ANTIKINK FITTING
33	PAE-S-780537	SEALING DISC FOR M20
34	PAE-S-9184106	LOCK NUT GMP-GL-M20X1,5
35	PLT-10-010	TAG LRP125 RFIP;25MM FOR HOIST
36	PLS-033050011	PLASTIC RING 5Xd 5,3X25X2,5
38	PAE-S-9104131	BOLT M3x8 INBUS 8.8 ISO10642
39	PAE-S-9102169	BOLT M6x25 INBUS 8.8 DIN7984
40	PAE-S-9102265	BOLT M6x12 INBUS 8.8 DIN7984
41	PAE-S-9102169	BOLT M6x25 INBUS 8.8 DIN7984
42	PAE-S-9102293	BOLT M6x25 INBUS 8.8 DIN6912
43	PAE-S-9102292	BOLT M6x35 INBUS 8.8 DIN6912
44	PAE-S-9101722	BOLT M6x25 INBUS 8.8 DIN7984 PRECOTE 80
45	PAE-S-9108066	BOLT M6x16 INBUS 10.9 ISK ISO7380 LENS HEAD
46	PAE-S-9101719	BOLT M3x6 INBUS 8.8 DIN 7984
47	PAE-S-670061	LOAD PIN AETOS 500
48	PAE-S-9123038	RETAINING RING DIN6799-12-FST
49	PAE-S-9129005	RETAINING RING DIN471-11x1
50	PAE-S-9129001	RETAINING RING DIN471-25x1,2
51	PAE-S-9129038	RETAINING RING DIN471-12x1



Part nr.	Catalog code PAE-1000DC	Description
1	PAE-S-671152	GEAR ASSY AETOS 1000
2	PAE-S-671157	MOTOR SPACER AETOS 1000
3	PAE-S-BC1000-01C+PAE-S-BC1000-05	BRAKECOVER AETOS 1000 COMPLETE + BRAKECOVER GASKET AETOS 1000
4	PAE-S-MC1000-01C+PAE-S-MC1000-05	MOTORCOVER AETOS 1000 COMPLETE + MOTORCOVER GASKET AETOS 1000
5	PAE-S-671139	MOTOR ASSY 400-230V, 3PH, 50-60HZ AETOS 1000
6	PAE-S-671208	Board Assy. f. DC-Control
7	PAE-S-0061003	TRANSFORMER PRI.400-230V SEC.24V
8	PLA-55-025	SMART LIMIT 440VOLT AC, 3PHASE
9	PAE-S-671171	CHAIN WHEEL COVER ASSY AETOS 1000
10	PAE-S-671159	CHAIN WHEEL COVER SEALING AETOS 1000
11	PAE-S-671161	GASKET MOTOR SPACER AETOS 1000
12	PAE-S-670757	CHAIN GUIDE HALF AETOS 1000
13	PAE-S-670190	LOAD WHEEL 7,1X20,5 CHAIN
14	PAE-S-671106	CHAIN STRIPPER AETOS 1000
15	PAE-S-670356	LIMIT SWITCH WIRE SEAL AETOS 500-1000
16	PAE-S-670152	SPACER BUSH 30X25X5 AETOS 1000
17	PAE-S-9120055	DISC SPRING 50x25,4x1,25 AETOS 1000
18	PAE-S-670148	CLUTCH HUB ASSY AETOS 1000
19	PAE-S-9151139	BAL BEARING 6002 DIN625 T1
21	PAE-S-671216	ASSEMBLED POWER LINE AETOS 500-1000
22	PAE-S-671150	DISENTANGLE PLATE AETOS 1000
23	PAE-S-671183	DISENTANGLE PLATE INSERT AETOS 1000
24	PAE-S-670395	ANCHOR COVER PLATE AETOS 1000
25	PAE-S-671158	LIMIT SWITCH ADAPTER AETOS 1000
26	PAE-S-671042	MICRO SWITCH ASSY AETOS 1000

Part nr.	Catalog code PAE-1000DC	Description
27	PAE-S-671194	BLIND PLUG SQUARE BLACK AETOS 500-1000
28	PAE-S-671198	BRAKE BFK457-08 AETOS 1000
29	PAE-S-671164	SUSPENSION HOOK ASSY AETOS 1000
30	PAE-S-671044	FASTENING STRAP
31	PAE-S-9131069	KEY 5X5X20 DIN6885-A
32	PAE-S-671145	CABLE GLAND WITH ANTIKINK FITTING
33	PAE-S-780537	SEALING DISC FOR M20
34	PAE-S-9184106	LOCK NUT GMP-GL-M20X1,5
35	PLT-10-010	TAG LRP125 RFI,25MM FOR HOIST
36	PLS-033050011	PLASTIC RING 5Xd 5,3X25X2,5
37	PAE-S-671220	BLIND PLUG
38	PAE-S-9104131	BOLT M3x8 INBUS 8.8 ISO10642
39	PAE-S-9102313	BOLT M6x30 INBUS 8.8 DIN 6912
40	PAE-S-9102281	BOLT M6x16 INBUS 8.8 DIN6912
41	PAE-S-9102054	BOLT M8x25 INBUS 8.8 DIN7984
42	PAE-S-9102306	BOLT M8x35 INBUS 8.8 DIN6912
43	PAE-S-9102301	BOLT M8x50 INBUS 8.8 DIN6912
44	PAE-S-9101718	BOLT M8x30 INBUS 8.8 DIN7984 PRECOTE 80
45	PAE-S-9108066	BOLT M6x16 INBUS 10.9 ISK ISO7380 LENS HEAD
46	PAE-S-9101719	BOLT M3x6 INBUS 8.8 DIN 7984
47	PAE-S-670185	LOAD PIN AETOS 1000
48	PAE-S-9123027	RETAINING RING DIN6799-15-FST
49	PAE-S-9129033	RETAINING RING DIN471-14x1
50	PAE-S-9129043	RETAINING RING DIN471-34x1,5
51	PAE-S-9129023	RETAINING RING DIN471-15x1



Part nr.	Catalog code PAE-1000LV	Description
1	PAE-S-671152	GEAR ASSY AETOS 1000
2	PAE-S-671157	MOTOR SPACER AETOS 1000
3	PAE-S-BC1000-01C+PAE-S-BC1000-05	BRAKECOVER AETOS 1000 COMPLETE + BRAKECOVER GASKET AETOS 1000
4	PAE-S-MC1000-01C+PAE-S-MC1000-05	MOTORCOVER AETOS 1000 COMPLETE + MOTORCOVER GASKET AETOS 1000
5	PAE-S-671139	MOTOR ASSY 400-230V, 3PH, 50-60HZ AETOS 1000
6	PAE-S-671174	BOARD ASSY. F. LV CONTROL AETOS 500 +1000
7	PAE-S-0061003	TRANSFORMER PRI.400-230V SEC.24V
9	PAE-S-671171	CHAIN WHEEL COVER ASSY AETOS 1000
10	PAE-S-671159	CHAIN WHEEL COVER SEALING AETOS 1000
11	PAE-S-671161	GASKET MOTOR SPACER AETOS 1000
12	PAE-S-670757	CHAIN GUIDE HALF AETOS 1000
13	PAE-S-670190	LOAD WHEEL 7,1X20,5 CHAIN
14	PAE-S-671106	CHAIN STRIPPER AETOS 1000
15	PAE-S-670356	LIMIT SWITCH WIRE SEAL AETOS 500-1000
16	PAE-S-670152	SPACER BUSH 30X25X5 AETOS 1000
17	PAE-S-9120055	DISC SPRING 50x25,4x1,25 AETOS 1000
18	PAE-S-670148	CLUTCH HUB ASSY AETOS 1000
19	PAE-S-9151139	BAL BEARING 6002 DIN625 T1
20	PAE-S-671215	ASSEMBLED CONTROL LINE AETOS 500 +1000
21	PAE-S-671216	ASSEMBLED POWER LINE AETOS 500-1000
22	PAE-S-671150	DISENTANGLE PLATE AETOS 1000
23	PAE-S-671183	DISENTANGLE PLATE INSERT AETOS 1000
24	PAE-S-670395	ANCHOR COVER PLATE AETOS 1000
25	PAE-S-671158	LIMIT SWITCH ADAPTER AETOS 1000
26	PAE-S-671042	MICRO SWITCH ASSY AETOS 1000

Part nr.	Catalog code PAE-1000LV	Description
27	PAE-S-671194	BLIND PLUG SQUARE BLACK AETOS 500-1000
28	PAE-S-671198	BRAKE BFK457-08 AETOS 1000
29	PAE-S-671164	SUSPENSION HOOK ASSY AETOS 1000
30	PAE-S-671044	FASTENING STRAP
31	PAE-S-9131069	KEY 5X5X20 DIN6885-A
32	PAE-S-671145	CABLE GLAND WITH ANTIKINK FITTING
33	PAE-S-780537	SEALING DISC FOR M20
34	PAE-S-9184106	LOCK NUT GMP-GL-M20X1,5
35	PLT-10-010	TAG LRP125 RFIP,25MM FOR HOIST
36	PLS-033050011	PLASTIC RING 5Xd 5,3X25X2,5
38	PAE-S-9104131	BOLT M3x8 INBUS 8.8 ISO10642
39	PAE-S-9102313	BOLT M6x30 INBUS 8.8 DIN 6912
40	PAE-S-9102281	BOLT M6x16 INBUS 8.8 DIN6912
41	PAE-S-9102054	BOLT M8x25 INBUS 8.8 DIN7984
42	PAE-S-9102306	BOLT M8x35 INBUS 8.8 DIN6912
43	PAE-S-9102301	BOLT M8x50 INBUS 8.8 DIN6912
44	PAE-S-9101718	BOLT M8x30 INBUS 8.8 DIN7984 PRECOTE 80
45	PAE-S-9108066	BOLT M6x16 INBUS 10.9 ISK ISO7380 LENS HEAD
46	PAE-S-9101719	BOLT M3x6 INBUS 8.8 DIN 7984
47	PAE-S-670185	LOAD PIN AETOS 1000
48	PAE-S-9123027	RETAINING RING DIN6799-15-FST
49	PAE-S-9129033	RETAINING RING DIN471-14x1
50	PAE-S-9129043	RETAINING RING DIN471-34x1,5
51	PAE-S-9129023	RETAINING RING DIN471-15x1



**EC DECLARATION OF CONFORMITY  
in accordance with Machinery Directive 2006/42/EC (Appendix II A)**

We,

**Prolyte Sales BV,  
Industriepark 9  
9351 PA Leek  
The Netherlands**

hereby declare, that the design, construction and commercialized execution of the below mentioned machine complies with the essential health and safety requirements of the EC Machinery Directive. The validity of this declaration will cease in case of any modification or supplement not being agreed with us previously.  
Furthermore, validity of this declaration will cease in case that the machine will not be operated correctly and in accordance with the operating instructions and/or not be inspected regularly.

**Machine description:**

Electric Chain Hoist AETOS series  
PAE-1000DC-XXXX  
PAE-1000LV-XXXX(H)  
PAE-500DC-XXXX  
PAE-500LV-XXXX(H)  
PAE-250DC-XXXX  
PAE-250LV-XXXX(H)

Capacity: 250 - 2000kg

**Serial number:**

Serial numbers for the individual units are recorded

**Relevant EC directives:**

EC Machine directive 2006/42/EC  
Directive for Electrical Equipment 2006/95/EC  
ROHS directive 2002/95/EC  
WEEE directive 2002/96/EC  
EMC directive 2004/108/EC

**Transposed harmonized  
standards in particular:**

ISO 12100: 2010  
EN 349: 1993 + A1: 2008  
EN 818-1: 1996 + A1: 2008  
EN 818-7: 2002 + A1: 2008  
EN 14492-2: 2008  
EN 60204-32: 1999  
EN 61000-6-2: 2005

**Transposed (either complete or in  
extracts) German standards and  
technical specifications in particular:**

DIN 15018-1: 1984, DIN 15400: 1990, DIN 15404-1: 1989  
BGV D6, BGV D8, BGV D8+

**Quality assurance:**

EN ISO 9001: 2008

**Authorized representative for technical data:**

Prolyte Sales BV, Industriepark 9, 9351 PA Leek, The Netherlands  
www.prolyte.com, www.prolyft.com

**Date of signing:**

01-01-2015

**Signed by:**

  
Michiel van der Zijde  
Product Manager Prolyft



## Prolyft Service Points:

Look at "service.prolyft.com" for the latest update

### Australia:

Design Quintessence  
Unit 72, Turner Street, Port Melbourne  
63-85  
Victoria 3207

### Belarus:

BelCultProject Service  
Kommunisticheskaya 10  
Minsk 220029

### Belgium:

Velleman NV  
Legen Heirweg 33  
Gavere 9890

### China:

Trinity Technology  
Xia Mao 1st21  
Guang Zhou 51425

### Croatia:

Perinic-Sistemi d.o.o.  
Vrhovec 28  
Zagreb 10000

### Denmark:

European Tour Production ApS  
Baadehavngade 42-44  
Copenhagen SV 2450

### Finland:

Hedcom Oy Ab  
P.O box 110  
Helsinki SF-00201

### France:

Axente  
Le Parc De l'Evenement, All 1  
Longjumeau F-91160

### Germany:

Fisher Vertriebsgesellschaft gmbh & co.  
KG  
Bruno Buergel Strasse 11  
Bremen D-28759

### Greece:

Omikron Pro Lighting  
Dervenion 31  
Athens 14451

### Hungary:

D.P.Music Kft.  
Ratz L. 72  
Pest 1119

### Indonesia:

Prolyft - Rajawali  
JI Mendawai I 52  
DKI 12130

### Italy:

AudioSales  
Via Ugo Bianchi 23  
Sorbolo 43058

### Korea, South:

Tongsuh tech  
#2001 bldg.B, Woolim Blue9 Biz.  
Center 240-21  
Seoul 157-861

### Latvia:

Pro 1  
Melluzu str. 1  
Riga LV 1067

### Lebanon:

Litewaves S.a.r.l.  
Lteif Street Haddad Building  
Beirut 1234

### Lithuania:

STS Stage Technical Services  
Aukstaiciu g. 7  
Vilnius LT-11341

### Malaysia:

P.A.P.  
The Highway Centre Lot 59-1 Jalan  
51/205  
Petaling Jaya 46050

### Mexico:

Gonher Pro Audio  
Norte 35 771  
Mexico City 02300

### Netherlands, The:

Prolyft  
Industriepark 9, 5M  
9351 PA Leek

### Netherlands, The:

Relight Productions BV  
Hoge Bergen 2  
4704 RH Roosendaal

### New Zealand:

Metro Productions Ltd  
Thorndon Quay 129-131  
Wellington 6141

### Norway:

MultiTechnic as  
Fernanda Nissensgate 1  
Oslo N-0401

### Philippines:

Stage Riggers  
Katarungan St, Plainview 515  
Metro Manilla 1550

### Poland:

Prolight Sp. z.o.o.  
Ul. 3 Maja 183  
Pruszkow 05-800

### Portugal:

Stagecom  
Rua Salgado Zenha, Lote 6  
Lisabon 2685 332

### Russia:

MF-Group  
Luzhnetskaya naberezhnaya 2/4 bld.  
16  
Moscow 119270

### South Africa:

DWR Distribution  
Block C, Unit 1, Kimbult Industrial Park  
9 Zeiss Road  
Johannesburg 2040

### Spain:

Fresnel SA  
Potosi 40  
Barcelona SP-08030

### Sweden:

Bellalite Ljusdesign AB  
Mörners väg 122  
Kronoberg 35246

### Taiwan:

Starship Engineering Co, Ltd  
Sec 2, Wuchang St., Wanhua District,  
124-2  
Taipei 108

### Thailand:

Dynamic Source co, Ltd.  
Moo 17 Phutthamonthon Sai 2Rd, sala  
Thammasop TheWee Wathana, 26/19  
Bangkok 10170

### Turkey:

Focus Reklam Ve Produksiyon  
Cendere Yolu 27  
Istanbul 34408

### Ukraine:

Lightek  
Galdara Str. 13, office 205  
Odessa 65078

### United Kingdom:

Black Light Ltd  
West Shore Road  
West Shore Trading Estate  
Edinburgh EH5 1QF

### United Kingdom:

Hawthorn Theatrical Ltd  
Crown Business Park 1  
Leicestershire LE 14 3NQ