

**DEX**

60

61

62

63

PROLYTE STAGE DEX





### **Profound material knowledge**

The Stage DEX system is one of the strongest and most versatile staging systems on the market for the building of temporary or demountable stages. Long-term practical experience and sublime production techniques were matched and led to the development of the Stage DEX staging system. The Stage DEX staging system is efficient and lightweight and has a high loading capacity.

### **Reliable constructions**

The Prolyte Stage DEX staging system offers the best possible way to construct a stage that covers all your requirements. Whether you have a wedding party, a business meeting, a special event, a dance night or a dinner party, the Stage DEX adapts flexibly and easily to all types of demands. The Stage DEX system has a broad range of accessories that make all sorts of set ups possible. Prolyte staging systems have earned a reputation as safe and solid constructions that adapt to all types of applications.

### **Adapts easily to your needs**

The Stage DEX staging system consists of an aluminium frame made from a special extruded profile. The plywood top is bolted and glued to this frame to reduce noise and vibration. Several leg types and support frames complete your staging system, along with numerous accessories. This makes the Stage DEX staging system very adaptable for different circumstances. Stage DEX can be transformed fast and easy, practically without the need for tools.

### **Application possibilities:**

- Banquet tables.
- Small stages for Disco Nights.
- Presentation platforms.
- Dance floors.
- Corporate events, stage for speakers.
- Risers, with or without wheels.
- Straight, curved or sloping catwalks.
- Tiered seating areas.
- Multi level floors.

### **User benefits:**

- User friendly design; no tools are needed.
- Low storage volume; compact building height, demountable leg system.
- Lightweight; can be assembled by one person.
- Cost effective; fast, flexible fit for several purposes.
- Integrated safety; complies to all current standardisation directives.

# CONTENT



## STAGE TYPES

top line, basic line

4



## ROTATING STAGE

6



## STAGING MODELS

models and measurements

7



## TECHNICAL SPECIFICATIONS

allowable loading, specs, do/don'ts

8



## LEGS TYPES

standard legs, adjustable legs,  
castor fitted legs and telescope legs

9



## RAMP

10



## EASY FRAME SYSTEMS

easy frame A, B and C

11



## PROBEAM

15

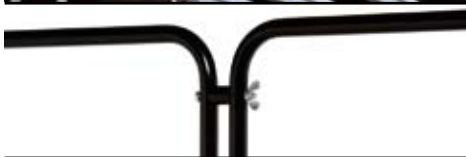

## EASY RAIL

easy rail 30 kg/m and 100 kg/m  
railing systems

16



## EASY STAIR SYSTEMS

adjustable and modular stair systems

19



## PRO EXPO FLOOR

flooring system for exhibition builders

22



## ASSEMBLY AND ACCESSORIES

23



# STAGING TYPES

Photo : PERINIC SISTEMI D.O.O., Zagreb, Croatia  
Project : Career day

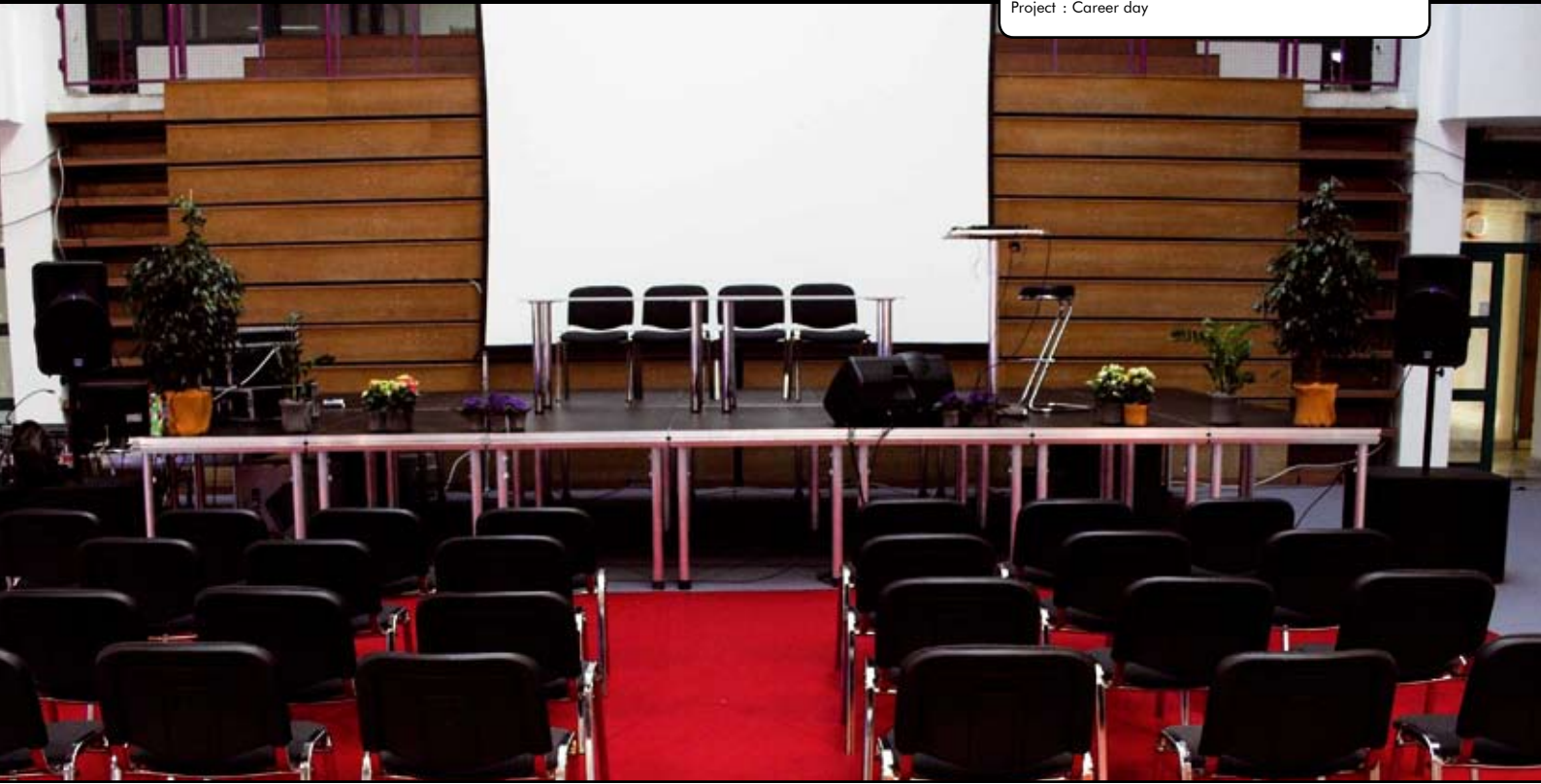

The Stage DEX staging system is made from a special extruded aluminium profile. The plywood top is bolted and glued to this frame to reduce noise and vibration.

**All decks are available in metric as well as imperial sizes.**

**NOW SIMPLY SELECT THE BEST SYSTEM FOR YOUR APPLICATION IN 2 SIMPLE STEPS.**

## 1. Choose your frame

### Top line frame

- Internal reinforcement of corner
- Standard spigot entry on the topside of the deck to attach easy rail system

### Basic line frame

- Internal reinforcement of corner

## 2. Choose your topping

### Top line topping

- Finished, extra durable topping.
- In- and outdoor use.
- Birch plywood, special water resistant quality.
- Anti skidding top layer.

### Basic line topping

- In- and outdoor use.
- Birch plywood, unfinished, indoor use only.
- Birch plywood, clear varnish.
- Birch plywood, black coating.



Birch plywood, special water resistant quality, anti skidding top layer



Top line frame



Birch plywood, unfinished indoor use only



Birch plywood, clear varnish water resistant



Birch plywood, black coating water resistant

Photo : Spijkerman Evenementen, Meppel, The Netherlands  
 Project : Theatertour Ilse de Lange in cooperation with EML

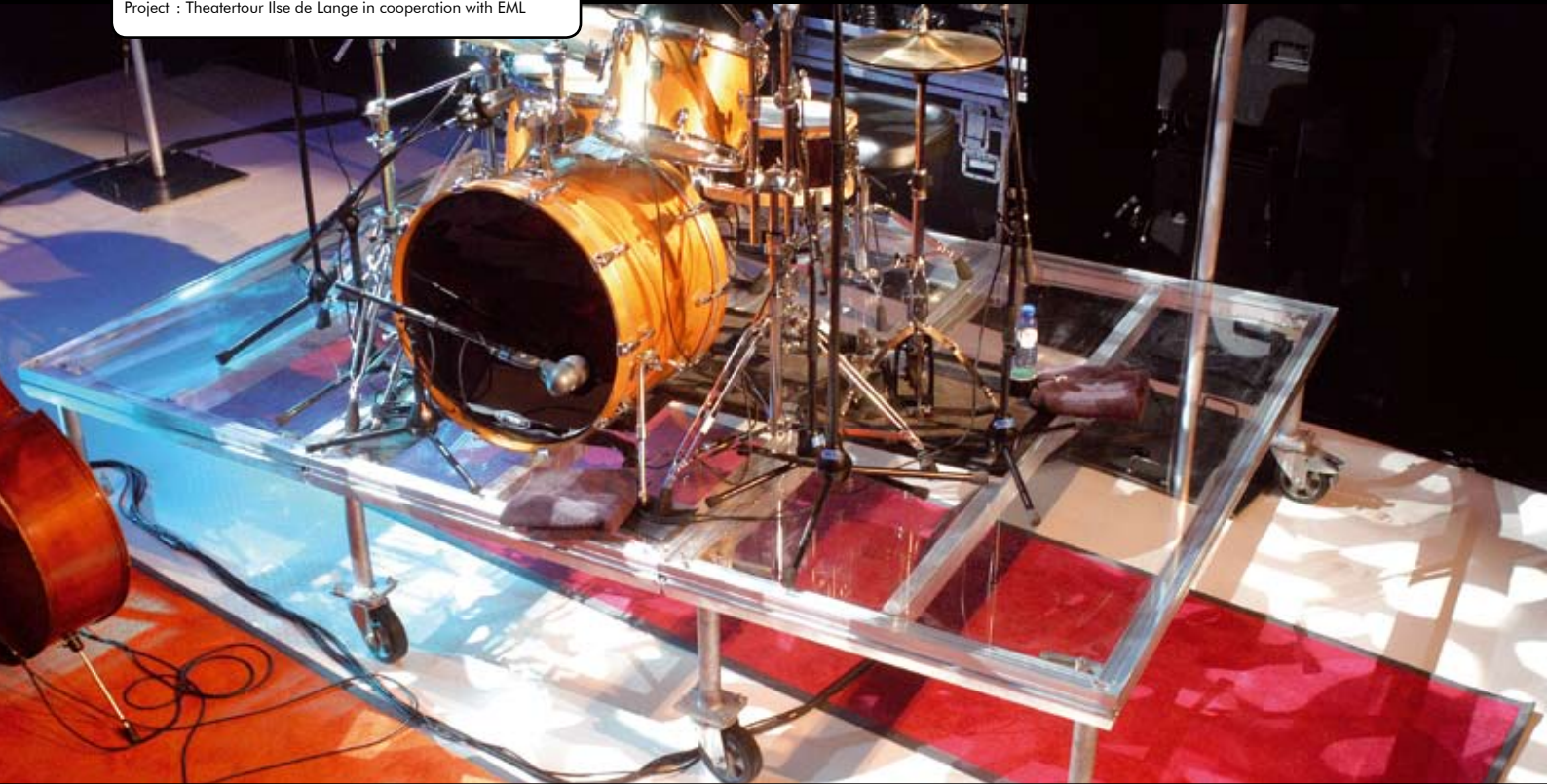

### Special topping

- Luxurious transparent decks for special applications. The transparent topping is made from durable, scratch-resistant polycarbonate.
- High load resistance, 500 kg/m<sup>2</sup>, can be combined with regular Stage DEX.
- Poly carbonate, transparent.
- Poly carbonate, frosted.

For both Stage DEX types Prolyte can supply different types of topping on request. Contact our Customer Service department for more information.

### CLEVER PARTS THAT MAKE THE DIFFERENCE

1. Choose a top line frame to have the advantages of a top based spigot entry, which allow simple and efficient mounting of handrails.



2. The universal leg fitting can hold square as well as round types of legs and fixates with one simple handle. The multi functional profile offers several add on extra's. Refer to the accessories pages.

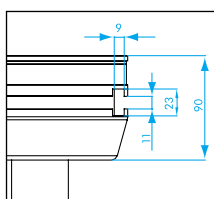

Poly carbonate, frosted  
 Poly carbonate, transparent

# ROTATING STAGE

Photo : Kimix, Belarus  
Project : The Bridal Fashion Show



## ROTATING STAGE

A fully integrated, plug & play revolve system to add some spice to your stage design. The Prolyte rotating stage offers flexible sizes, step less variable speed control and a clever construction that guarantees effortless set up and dismantling.

### System description

The rotating stage consists of 4 basic parts:

- The base frame, incl. screw jacks.
- The central bearing ring.
- Top frames for 2, 4 and 6 m diameter stage, with integrated wheels, motor and controller.
- Plywood topping.

### System advantages

- Lightweight due to aluminium frames.
- Flexible measurements, the modular frames are easy extendable from 2 to 6 m diameter.
- Short building time required, due to clever connection and integrated parts.
- User friendly control due to plug and play motor and control unit.
- All levelling and connection is done from topside.

Technical Specifications Rotating Stage	
Measurements	Available in 2, 4 and 6m. diameter
Height	200 mm, adjustable to 220 mm
Max. Allowed load (UDL)	4000 kg for 2 and 4 m diameter 6000 kg for 6 m diameter
Max. Point load	750 kg (min. bearing surface 200x100 mm)
Max. Turning speed	0,3 m/sec (max. allowable speed as per German guidelines)
Main Power	16A, 200V-240V single phase, 50Hz
Soft start/stop	Frequency controlled motor
Power Outlet	220V / 10A outlet available on stage
Base frame	Steel base frame and central bearing ring Aluminium top frames with integrated wheels
Topping	21 mm plywood unfinished
Tooling	Hexagon key 12 mm, Wrench 12 mm
Set up time	approx. 2 hours



## USE YOUR IMAGINATION

Imagination is the only restriction to the staging solutions that the Stage DEX system offers. Stage DEX can be transformed fast and easy, practically without the need for tools. The Stage DEX comes in a variety of standard sizes and shapes, so every possible stage can be constructed.

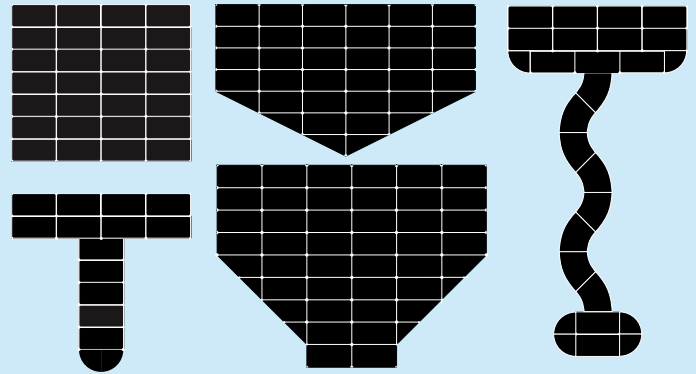

SM-D750-1

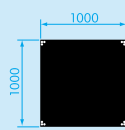

SM-D750-2



SM-D750-3

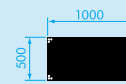

SM-D750-4

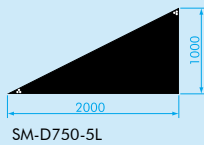

SM-D750-5L

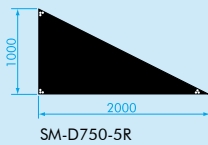

SM-D750-5R

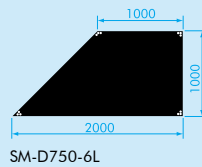

SM-D750-6L

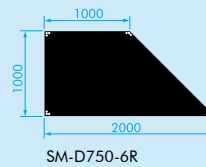

SM-D750-6R

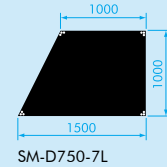

SM-D750-7L

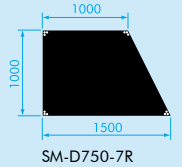

SM-D750-7R

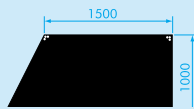

SM-D750-8L

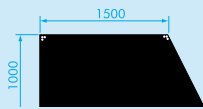

SM-D750-8R

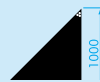

SM-D750-9

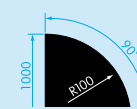

SM-D750-R1

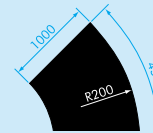

SM-D750-R2

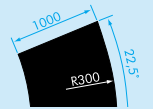

SM-D750-R3

## CIRCULAR STAGES

Polyte is able to fabricate circular stages that are actually based on curved segments, this makes the Stage DEX Staging system quite unique. The curved segments are manufactured with a high degree of accuracy ensuring a perfect fit with no distortion.

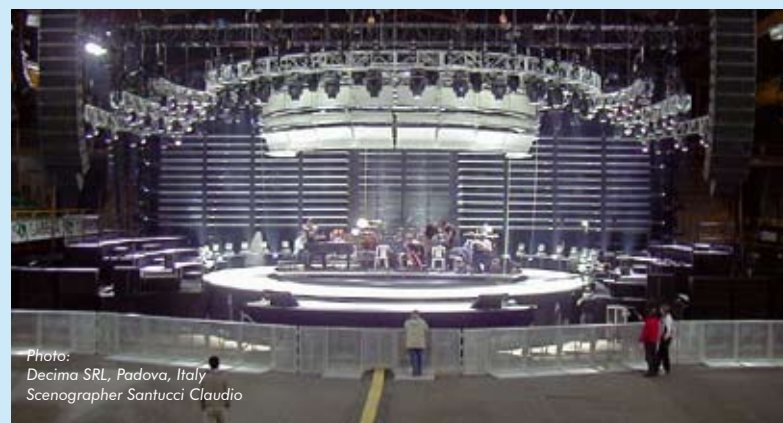

Photo:  
Decima SRL, Padova, Italy  
Scenographer Santucci Claudio

## STANDARDS

Standards that apply to Polyte stages and temporary constructions

EN 13814	Fairground and amusement park machinery and structures – Safety.
EN 13782	Fairground and amusement park machinery and structures – Safety - Tents Safety.
DIN 4113	Parts 1, 2, and 3 Aluminium constructions under predominantly static loading.

DIN 4112	Temporary structures, fairground amusements, directives for dimensioning and construction.
DIN 1055	Action on structures – all Part 4.
DIN 18800	Steel structures.
DIN 15920	Stage and studio set-up: Safety regulations for practicals, ramps, steps, stairs and railings.

# TECHNICAL SPECIFICATIONS

## DEFINITION

At this time there are no strict definitions known for a stage as used in the entertainment market. A stage or stage floor is essentially a temporary raised platform to accommodate performances of any kind at public or private events

## APPLICATION

Stages, stage floors, raised floors and raised seating area's are used in the event, hotel and exhibition market, which can be defined as (but not restricted to) all activities for leisure and sports, arts and cultural performances, amusement, or presentation of products.

Stage Dex - Allowable loading for different leg types					
LEG TYPES	UNIFORMLY DISTRIBUTED LOAD kg/m <sup>2</sup>				
STAGE HEIGHT IN CM	80 cm	100 cm	120 cm	160 cm	180 cm
tube 48,3 x 4 (EN AW 6060 T5)	500	500	350	350	n.a.
tube 48,3 x 3 (EN AW 6082 T6)	750	500	500	350	n.a.
tube 48,3 x 4 (EN AW 6082 T6)	750	750	500	500	350
tube 48,3 x 3 (ST37)	750	750	500	500	500
tube 40 x 40 x 3 (EN AW 6082 T6)	500	500	500	350	n.a.
tube 40 x 40 x 2 (ST 37)	500	500	500	350	350
Telescopic leg	stage height 450mm-1400mm 350-750 kg/m <sup>2</sup>				
n.a. = not allowed					
all data based on a standard deck of 2 x 1m					
Calculated with 1/10 of the vertical load transferred into a horizontal load (conform DIN 4112 / EN 13814)					
Loading types					
uniformly distributed load	750 kg/m <sup>2</sup>				
pointload F1	350 kg				
pointload F2	210 kg				
pointload F3	500 kg				
the pointload should be applied to a minimum area of 50 x 50 mm.					
pointload to be placed as indicated on drawing. 1 pointload total allowed.					

Technical Specifications Stage Dex	
Types	standard, standard arched, basic
Frame	Aluminium (EN AW 6005A T6)
Topping	Plywood
Legs	48,3 x 3 mm (EN AW 6082 T6)
Legs with adjustable feet	48,3 x 3 mm (EN AW 6082 T6), with steel spindle on pvc base
Telescopic leg	48,3 x 4 / 60 x 5 mm (EN AW 6082 T6)
Max. load	750 kg/m <sup>2</sup> UDL
Self weight	37 kg

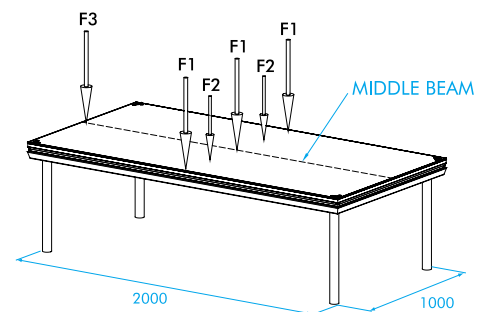

## DO NOT

- Use material in poor condition, the payload might be reduced substantially.
- Apply loads before knowing their exact weight and size.
- Exceed the max. allowable load.
- Use unfinished Stage DEX toppings in outside conditions.
- Exceed the max. building height of the stage or its support frame.
- Use the hang-on profile without reducing the max. allowable payload.
- Build your stage on unstable soil.
- Use Stage DEX elements as ballast for your roof without using the proper support frame.

## DO

- Check if the Stage Floor is properly aligned and completely level.
- Check the application conditions of your stage, the type of use is directly related to safety issues like handrails.
- Brace your staging legs when needed for stability reasons.
- Make sure all stage elements are interconnected.
- Take notice of local regulations for stages and their purposes.
- Store Stage DEX upside down to decrease set-up time.
- Maintain your Stage DEX on regular intervals.
- Inform your crew beforehand on safety procedures in case of emergency situations like evacuation procedures.
- Make sure your construction is properly grounded.

## Need to know more?

Please go to [www.prolyte.com](http://www.prolyte.com) for more technical information on Prolyte Stage DEX systems, manuals and loading tables.

In the Prolyte Black Book (technical background information) we provide more in-depth technical knowledge on stages and stage floors.

## THE STAGE DEX LEG FITTING IS PROOF OF OUR LOW TECH BUT INGENIOUS ENGINEERING SOLUTIONS.

- No tools needed.
- The legs are fitted to the deck frame and are fixed in position by one simple handle.
- Round as well as square legs can be mounted in the leg fitting.

**Notice:** The types and the length of the legs that are used determine the amount of loading that is allowed. Be sure to always check the loading table before you apply any loads to the decks.

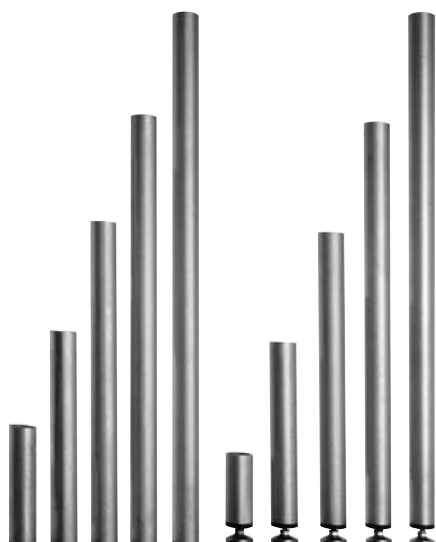

### STANDARD LEGS

Round Aluminium tube 48,3 x 3 mm in heights of 200-1000 mm.  
Code: SM-L-••A

### ADJUSTABLE LEGS

Round Aluminium tube 48,3 x 3 mm in heights of 200-1000 mm, with adjustable feet.  
Code: SM-L-••A-ADJ



### CASTOR FITTED LEGS

Round Aluminium tube 48,3 x 3 mm in heights of 200-1000 mm, with castor.

Code: SM-L-••-CAS-01 = single leg with castor  
SM-L-••-CAS-02 = single leg with castor/brake  
SM-L-••-CAS-03 = double leg with castor  
SM-L-••-CAS-04 = double leg with castor/brake



### TELESCOPIC LEGS

The unique concept of the Prolyte telescopic leg combines adjustable height and high loading capacity.

- Sturdy road proof mechanism.
- Build in tape measure for easy mounting.
- The telescopic leg can support the maximum allowable loading of the Stage DEX, being 750 kg/m<sup>2</sup>.

#### How does it work?

- Release the two M10 hexagon socket head screws or crank handles.
- Extend the leg to its required length.
- Lock the leg at both positions to guarantee optimal grip of the telescopic mechanism.
- Measures on the inside of the profile indicate the total length of your leg and safe using boundaries.
- The rubber cap will prevent any damage to your flooring system.

#### Code:

SM-L-45/60-ADJ  
Telescopic leg 450-600 mm.

SM-L-60/90-ADJ  
Telescopic leg 600-900 mm.

SM-L-90/140-ADJ  
Telescopic leg 900-1400 mm.

# RAMP

Photo : PERINIC SISTEMI D.O.O., Zagreb, Croatia  
Project : F=M



## STAGE DEX RAMP

The Prolyte Stage DEX ramp is developed to fulfil the demands of numerous stage DEX users to be able to broaden the possibilities of the Stage DEX line. The ramp is fully compatible to the complete Prolyte Stage DEX line. The ramp can be used for several applications, like car shows, walkways, fashion catwalks, and passageways for wheelchairs or as a plain ramp to create stage access.

The Stage DEX ramp consists of three basic elements:

- Adjustable legs fitted with stabilizers.
- Standard Stage DEX.
- Aluminium side profiles (SM-RP-BE2).

The allowable loading is 750 kg/m, which is the standard loading on all Stage DEX. In order to accommodate heavy loading, such as cars, the side profiles are designed to absorb the forces resulting from such point loading. The standard sloping angle is 7,5 degree, but can be varied from 0-22 degree by adjusting the plate connected to the legs. This adjustment guarantees the resulting forces from the loading to be transferred at a correct angle into the leg.

Notches on top of the profiles keep the DEX in place, once the ramp is build. The first and last DEX are connected to the DEX of the sloping part of the ramp by a standard coupling profile.

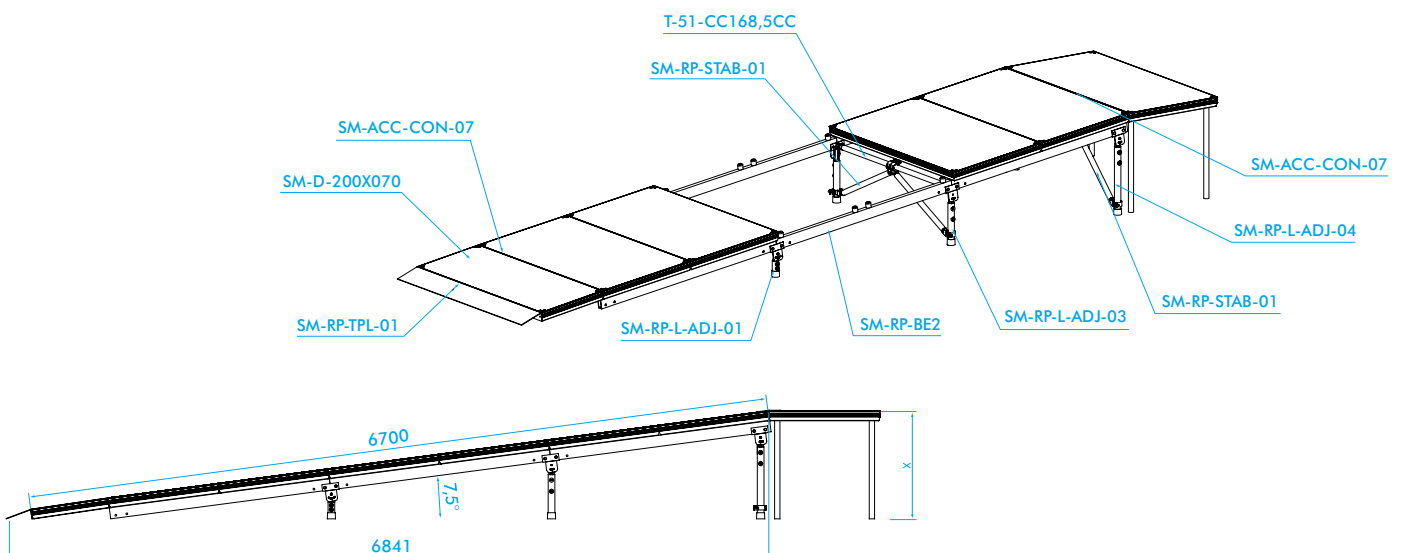

Photo : Amsterdam Arena  
Project : Stage frame A



For many applications you need more than a couple of legs to support your stage. For any stage floor build above the height of 100cm, using legs would seriously affect the loading capacity of your stage. Stage DEX offers several solutions for this purpose. The Easy frame A, B and C are support systems that are easy to build and require little production time.

## EASY FRAME A

### System Description

Support frame suitable for indoor use with a variable height of 1000 to 2700 mm. The top and bottom frames are connected through an internal tube system with pre-fabricated holes at each 50 mm. These holes make it possible to vary the height from 1000 mm to 2700 mm in steps of 50 mm. Adjustable feet, with integrated screw jacks, in the bottom frame, make it possible to level the stage at an exact position. By using the top frame only, a minimum stage height of 1000 mm can be obtained.

### Advantages

- Crosswise corridors facilitating free under stage access.
- The maximum allowable load of 750 kg/m<sup>2</sup> and 10% horizontal load are guaranteed.
- Standard stage elements provide your stage floor.
- Outside stage measurement is outside support construction.
- Fast assembly, no tools and a minimum amount of loose parts.
- Low self weight.



**Step 1:**  
Place bottom frames (SM-F-A-BF1) where wanted. Connect braces (SM-F-A-BR-050) to bottom frames. The braces are available in lengths of 500 mm, 1000 mm and 2000 mm.

**Step 2:**  
Insert the inside leg (SM-F-A-IL3) into the bottom frame and connect with L-pin. Four legs per frame are needed. The length is 1400 mm. The SM-F-A-IL1 (800 mm) and IL2 (1000 mm) can be used without bottom frame and attach directly to the top frame. Two (double) legs are needed per frame.

**Step 3:**  
Place the top frames on the inside legs and connect with L-pin. Connect the compression braces (SM-F-A-BRC-050) where needed to the top and bottom frames. The compression braces are available in lengths of 500 mm, 1000 mm and 2000 mm.

**Step 4:**  
Place the decks on the special knobs on top of the top frames. Make sure your first section is 100% level.

**Step 5:**  
Interconnect the complete frames with the supporting beams (SM-F-A-BE-1) to achieve a free span between the supporting frames. These beams are available in lengths of 1088 mm and 2089 mm (for 1 of 2m. decks). Place the decks on the special knobs on top of these beams. Level the complete stage by means of the adjustable feet in the bottom frames.



## EASY FRAME B

### System Description

Support frame suitable for out- and indoor use. The frame racks are available in several heights and in lengths. The frames connect to the legs with a standard 4-way connection by means of a locking pin. Due to the closed topside, one technician only can do the assembly. After positioning, the frames stand free, without toppling over. Spindle feet, placed in the bottom of the frames, make it possible to level the stage at an exact position and to vary the height of your stage floor.

### Code:

SM-F-B-R• 00100, rack 1000 mm height, minimum stage floor height variable between 1200-1600 mm.

SM-F-B-R• 00150, rack 1500 mm height, minimum stage floor height variable between 1700-2100 mm.

SM-F-B-R• 00200, rack 2000 mm height, minimum stage floor height variable between 2200-2600 mm.

### Advantages

- Interconnected framework can act as ballast systems for roof constructions.
- Can absorb horizontal forces resulting from eventual wind forces on the roof.
- Interfaces for all Prolyte roof systems available.
- Fit for various brands of staging by using special adapters to secure your decks.
- The maximum allowable load of 750 kg/m<sup>2</sup> and 10% horizontal load are guaranteed.
- Standard stage elements provide your stage floor.
- Fast assembly, no tools and a minimum amount of loose parts.

### Ballast system

Stages are often used in combination with temporary roof structures. If used in the right way, the weight of your stage floor can act as a ballast system for the roof construction.

The Easy frame B support system is thus constructed that the complete stage floor is interconnected. If the stage is lifted at one end, the complete stage will be lifted. Only constructions that comply with these criteria may act as ballast system for roof constructions. Apart from this fact the Easy frame B is suitable to absorb the horizontal forces resulting from the base sections of the roof towers. Prolyte can supply interfaces for all Prolyte roof systems.

## EASY FRAME B



**Step 1:**  
Place the leg with 4-way joint (SM-F-B-L....) where wanted. The leg is available in lengths of 1000mm, 1500mm and 2000mm.

**Step 2:**  
Connect the frame rack (SM-F-B-R....) to the leg and fix with the L-pin. The ladder frames connect to the 4-way joint by means of a pen/fork connection which is closed on the top side (the fork "rests" on the pen). After positioning the parts can stand free, without toppling over. This makes the assembly of the locking pin easy.

**Step 3:**  
Place the deck to frame adapter (SM-F-B-ADAP-01) in the leg fittings of your deck.

**Step 4:**  
Place the decks on top of the assembled frames. Level the stage by means of the spindle feet in the legs.



### Dex to frame adapter

In order to safely mount the decks to the Easy Fame B system, Prolyte has developed the DEX to Frame adapter. This adapter is mounted in the leg connection and prevents any horizontal movement of the stage decks.



(SM-F-B-ADAP-01)

# EASY FRAME SYSTEMS; EASY FRAME C

Photo : Prolyte Products BV, Marcel Meijer  
Project : Concert Jan Smit



## EASY FRAME C

### System Description

From multi level stage to seating area or tribune in one go. Based on customer experience, Prolyte wanted this new support frame to be as flexible and multi-purpose in use as possible.

### Economic investment

The Stage DEX EASY FRAME C can be used for flat stages as well as raised platforms or bleachers. This makes the initial investment very economic, since only one system can be purchased for several applications. The very quick assembly also diminishes building times. The free corridors, which can be created under the stage, allow for handy storage space for your empties or are the ideal location for dimmer city or other use.

### Easy does it

The set up of an EASY FRAME C is practical and fast and requires only one tool. Due to lightweight material, only one technician is needed to handle each part.

There are two basic types of EASY FRAME C; Sub frame 1 varies in height between 100-150 cm, Sub frame 2 varies between 160-270 cm. All intermediate steps are either standard or tailor made by means of the hole distance in the inside legs. Optional screw jacks or castors give you the opportunity to build a rolling stage as well. Standard stage DEX are fitted to the top of the EASY FRAME C system with a stage DEX adapter, which fixes the DEX horizontally as well as vertically.

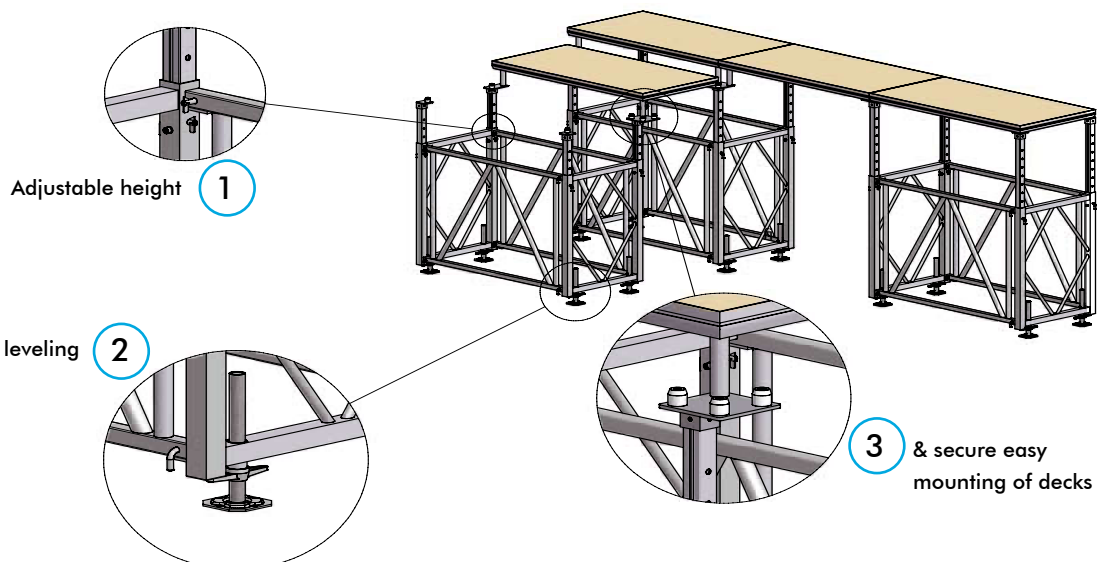

Photo : Prolyte Sales, Spijkerman evenementen  
Project : Concert at Sea



Probeam Main Beam Probeam Cross Beam

**System Description**

PROBEAM offers an economic and clever solution that uses the benefits of both scaffolding and Stage DEX staging systems. The PROBEAM main beam has wedge head couplers on both ends that connect simply by sliding the wedge head over the rosette and inserting the wedge into the hole. The PROBEAM cross beam has extended support ridges, to fit the PROBEAM main beam. Strength and high stability of the PROBEAM guarantees symmetrical and fool proof building.

**System details**

- PROBEAM main beam available in lengths of 1000 mm, 2000 m and 1036 mm and 2072 mm.
- PROBEAM cross beam available in lengths of 1000 mm, 2000 m and 1036 mm and 2072 mm.
- The main and cross beams can be ordered without wood, with basic line wood black or with a top line wooden inlay.
- Covers can be ordered in 3-way and 4-way version, with or without centre hole.

**Simple, Flexible, Convertible**

The PROBEAM is designed for three different applications:

1. The PROBEAM converts the scaffolding system measurements (2072 mm) into the metric stage DEX system, to create a floor on scaffolding size. The PROBEAM is fitted with a wooden inlay to overcome the 72 mm difference.
2. By adding a special lid to the PROBEAM, you can create a stage DEX floor on a metrical 2000 mm x 2000 mm scaffolding system.
3. The PROBEAM system combined with a wooden inlay can be used as supporting frame when normal plywood is used as flooring system.

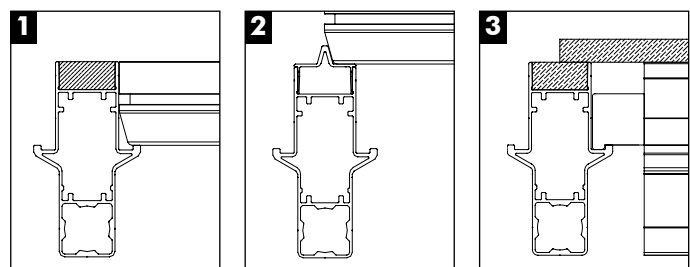
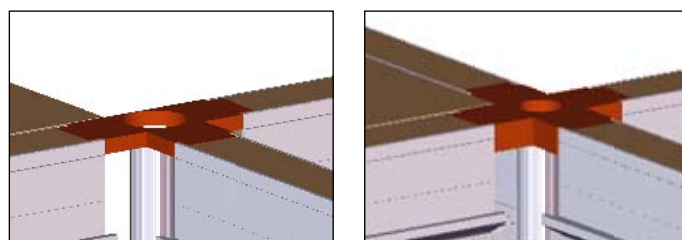

# EASY RAIL

Photo : Metro Productions LTD New Zealand.  
Project : King Kong premiere in Wellington.



## EASY RAIL

### System Description

Handrails and other accessories from the Easy rail range can easily be attached to the decks by inserting a spigot in a pre-bolted hole on each corner of the deck. This makes it possible to assemble the rails after the decks are built, being completely independent from the sides or underlying constructions of the stage.

For the basic line decks Prolyte has developed special adapters for the spigots, which slide into the side profiles of the decks. The Easy rail comes in two different versions, both in compliance with the applicable standards (DIN 4112 and DIN 1592-0/11).



## EASY RAIL 30 kg/m

The light duty version of the easy rail can resist a horizontal loading of 30 till 60 kg/m. This railing type can be used for stages or areas with no public access. This is the case for most commonly used stages. For top line decks the railing can be easily mounted on top of the decks by simply bolting a 26 mm spigot to the pre-drilled hole. The railing is available in a fixed and an adjustable type.

## Fixed rail:

SM-RAIL-L100, length 1000 mm.

SM-RAIL-L200, length 2000 mm.

## Adjustable rail:

SM-RAIL-L85/140, adjustable from 850 to 1400 mm.

SM-RAIL-L140/210, adjustable from 1400 to 2100 mm.

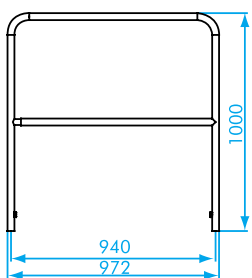

Easy Rail railing. SM-RAIL-L100.

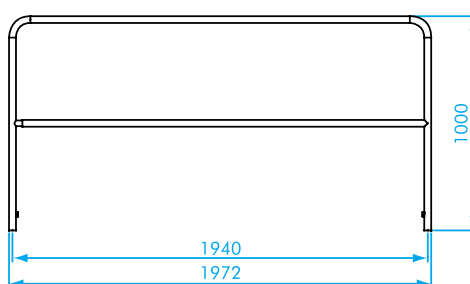

Easy Rail railing. SM-RAIL-L200.

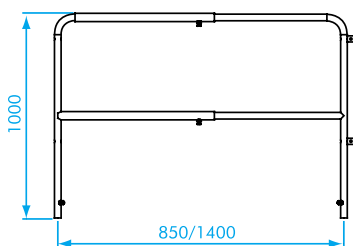

Easy Rail railing. SM-RAIL-L85/140.

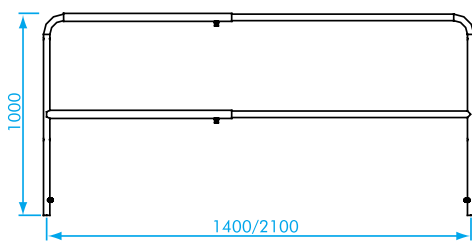

Easy Rail railing. SM-RAIL-L140/210.

## Accessories:

SM-RAIL-ATT-01, Spigot 26 mm for top line deck.

SM-RAIL-ATT-04, Adaptor with spigot for basic line deck.

SM-RAIL-CON, railing connector.



SM-RAIL-CON



SM-RAIL-ATT-04



# EASY RAIL

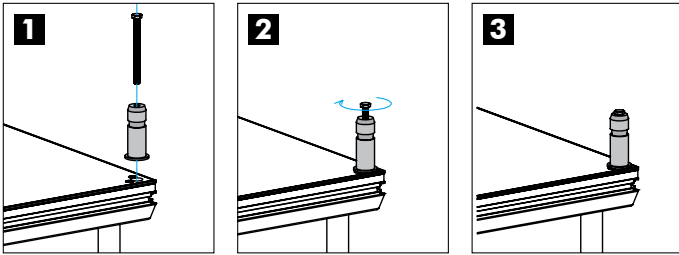

Spigot attachment: 30 kg rail on top line only!

Spigot  
SM-RAIL-ATT-01



## EASY RAIL 100 kg/m

The heavy-duty version of the easy rail can resist a horizontal loading of 100 till 200 kg/m. This railing type can be used in all circumstances, whether your stage has public access or not, the railing is in compliance with the applicable regulations.

The railing can be easily mounted on top of the decks by simply bolting a 40 mm spigot to the pre-drilled hole, hereby using the special railing adaptor.

The railing adaptor has an extra M12 hole drilled in front of the spigot hole. An extra spigot can be bolted in place here, to provide a connection for a corner rail. This type of rail can only be used in combination with top line decks.

### Railing lengths:

SM-RAIL-H-L100, length 1000 mm.  
SM-RAIL-H-L200, length 2000 mm.

### Corner pieces:

SM-RAIL-H-L093C, length 930 mm.  
SM-RAIL-H-L193C, length 1930 mm.

### Accessories:

SM-RAIL-ATT-02,  
Spigot 40mm for top line deck.  
SM-RAIL-ATT-03,  
Adaptor for 100kg/m rail for top line deck.

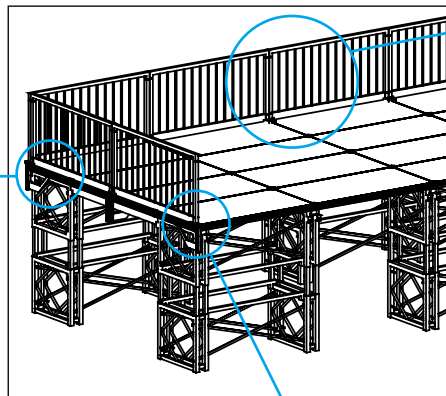
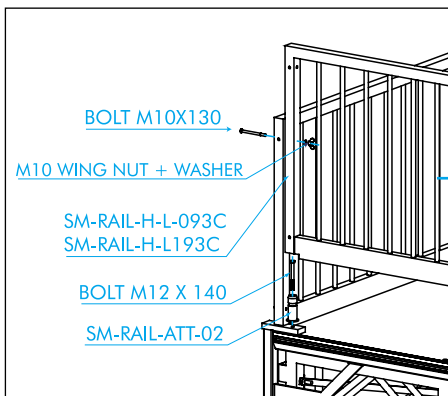

Spigot attachment:  
100 kg rail on top  
line only

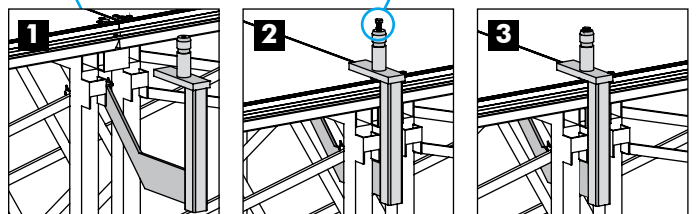
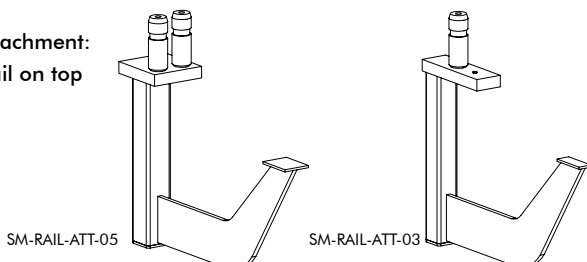

Photo : Diep Triest, Those were the days



## ADJUSTABLE STAIR

### System Description

This unique, fully adjustable, staircase consists of separate units, which can be combined to a staircase between 1 m. minimum and 3,2 m maximum height.

The units are based on four main beams of 60 x 6 mm tube to which the stair steps are connected. The stair steps are flexible and have a varying angle of 45 till 60 degree.

The adjustable stair is designed for a maximum loading of 500 kg/m<sup>2</sup>.

### Basic Elements:

#### Top side:

SM-STAIR-500, basic element with 6 steps. The upper step aligns with your stage floor. This basic element is connected to the stage by means of a profile that is bolted to the stage with a T-head bolt M10 x 20 mm which is placed in the stage DEX profile.

#### Bottom side:

The SM-STAIR-510 base section. Connects to the stair elements by means of a CCS7 coupler combined with the CCS7 hinge (CCS7-H-FM-90).

### Step units:

To elongate the basic element, extra step units can be mounted, these units range from 1 till 5 steps. Several units can be coupled, to reach the maximum allowed height. The extra units are connected using the standard CCS7 coupling system.

SM-STAIR-501, 1 STEP BEAM.

SM-STAIR-502, 2 STEP BEAM.

SM-STAIR-503, 3 STEP BEAM.

SM-STAIR-504, 4 STEP BEAM.

SM-STAIR-505, 5 STEP BEAM.

### Handrails:

Mounting the handrails completes the staircase. The railing can be combined from three parts:

- SM-STAIR-520 is the adjustable basic part, can be coupled, to cover the full height of your stair.
- SM-STAIR-521 is the rounded end part.
- SM-STAIR-522 is rectangular end part to which another railing can be coupled.

The railing parts can only be mounted on the SM-STAIR-500 and the SM-STAIR-505.

The railing is mounted to the main tube using the standard spigot (SM-RAIL-ATT-01), which is bolted to the tube using a M12 x 200 mm bolt.

# EASY STAIR SYSTEMS

Photo : Belcult Project, Belarus  
Project : Palace of the Republic, ST roof with Easy frame B

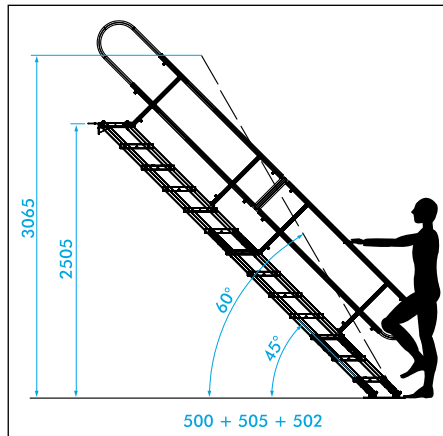
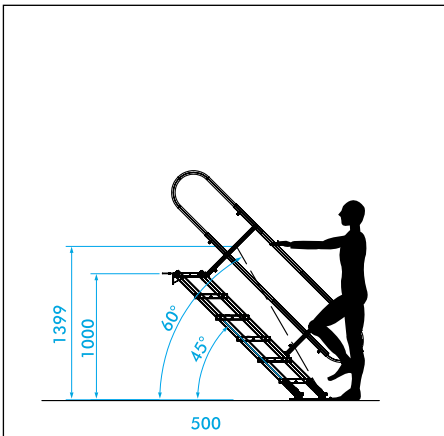
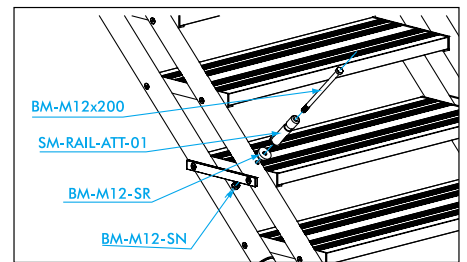
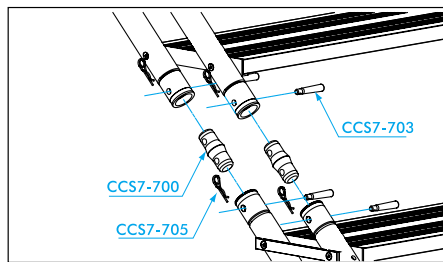
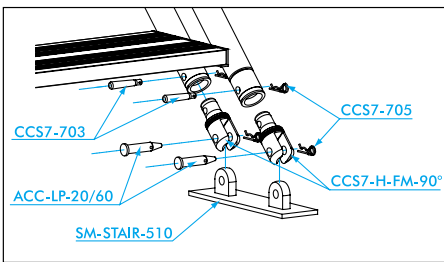

## STAIR HEIGHTS USING DIFFERENT COMBINATIONS

all measurements in mm	500	500+501	500+502	500+503	500+504	500+505
A (stair angle 45 degree)	1000	1344	1537	1731	1924	2118
B (stair angle 60 degree)	1399	1636	1873	2110	2346	2584

all measurements in mm	500+ 505+ 501	500+ 505+ 502	500+ 505+ 503	500+ 505+ 504	500+ 505+ 505
A (stair angle 45 degree)	2311	2505	2699	2891	3075
B (stair angle 60 degree)	2829	3065	N/A	N/A	N/A

max. allowable stair height 3,2 m.

# EASY STAIR SYSTEMS

Photos : Metro Productions LTD, New Zealand  
Project : King Kong Premiere, Wellington, New Zealand



## MODULAR STAIR

### System Description

Separate stair units can be combined to a stair of any desired height in steps of 20 cm, by simply bolting them together. The units can be connected to both sides, which makes it possible to create a staircase of several heights as well as different widths.

The railing can be connected to the sides of the stairs, but also in between the steps, thereby creating the possibility to have a separate up and down staircase.

The measurements of the individual stair units are: 910 x 225 mm.

Each stair unit has an angular profile to one side, this makes it possible to fit the stairs directly to the DEX to create an even level. The stair unit can be mounted using the T-bolts.

The SM-STAIR-CON-01 special clamp is available to mount stair units to the DEX legs.

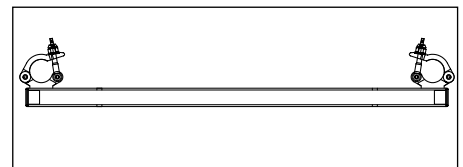

SM-STAIR-CON-01



# PRO EXPO FLOOR



## System Description

The Pro Expo Floor is a floor covering system for exhibition builders and other applications where a secondary flooring or integrated floor planning is needed. Not only is the Pro Expo Floor suited to cover cabling or drainage systems underneath the stand area, further it increases the sound insulation and offers a neat and clean look to your stand or performance area. The Pro Expo floor is fast, easy and efficient. User demands and clever product design are combined in this simple, but effective floor covering system.

## Advantages:

- Anti skidding and water resistant material through use of phenol coated wire mesh plywood.
- High load bearing of 3000 kg/m<sup>2</sup>, through sandwich panel construction.
- Removable, adjustable and lightweight feet, no additional parts needed.
- Foolproof assembly, minimum amount of different parts.
- Lightweight system, can be build by one person only.
- Limited amount of tooling necessary.
- Flexible use through clever hole pattern (25 different feet positions per unit), several lay-out patterns possible.
- Fast and easy levelling possible, through topside adjustable feet spindle.
- Compact transportation and storage volume.

Technical Specification Pro Expo Floor	
top layer	3,6mm plywood with 120 gr wire mesh phenol coating
kernel	plywood honeycomb structure
bottom layer	wire mesh plywood 120 gr, 3,6 mm
sides	40 mm pinewood
total panel thickness	40 mm
weight per unit	8 kg
measurements full unit	997 x 997 mm
hole pattern for feet positioning	included
max. allowed load (UDL)	3000 kg/m <sup>2</sup>
max. point load (min. bearing surface 200x200 mm)	1500 kg
fire resistance	DIN 4102 B2
feet	glass fibre reinforced PA
feet weight	300 gr
feet min-max size (inside)	60-105 mm
feet min-max size (outside)	100-145 mm
tools needed	hexagon key 6

Available sizes	
full unit	997 x 997 mm
half unit	997 x 498 mm
quarter unit	498 x 498 mm
transit unit (for lead through of cabling and drainage)	997 x 997 mm + 200 mm feed hole
diagonal units available on request	

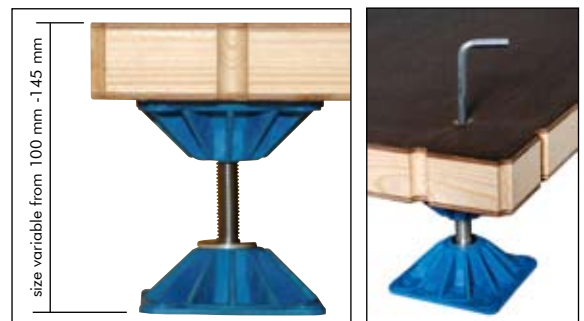

## DEX LEVELLER

Use the DEX leveller to keep your stage system exactly level and to prevent any vertical movement between the decks. Simply slide the cube into the side profile of the decks. Once the adjoining deck is placed the DEX leveller keeps both decks at precisely the same height.

A safe and even stage floor, free from tripping hazards, is the result. The DEX levellers can be delivered in several lengths on request.

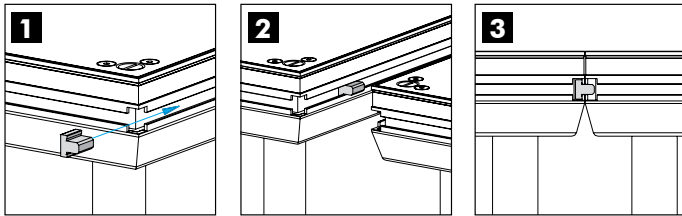

## DEX CONNECTOR

The DEX Connector not only keeps your stage floor exactly level, but connects the decks as well. The DEX Connector slides into the side of the profile and is fixed with the aid of a simple hex key; it can be used in combination with the DEX Leveller. The DEX Connector is specially designed for those circumstances where the leg-to-leg clamp cannot be mounted, like:

- Low stages. There are no legs or the legs are too short to be able to mount the clamp.
- Angular or curved stages. The centre-to-centre distance of the legs at the angular corners of the stage is too large to mount the clamp.



## COUPLING PROFILE

The coupling profile is an easy method of coupling your Stage DEX system and still be able to rake them at a certain angle. This offers the ideal solution for building ramps, sloping walkways or passageways for wheelchairs. The profile slides into the side of the decks; the adjoining deck is safely attached. The maximum raking angle is 30 degrees.



(SM-ACC-CON-03)

## DEX LEG FIXATION

SM-ACC-CON-09

Steel bracket to position stage and keep leg in place. For tiered seating or multi level stages.

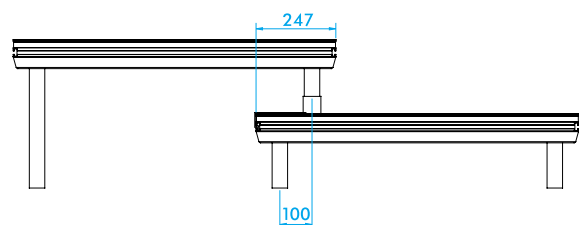

## ASSEMBLY AND ACCESSORIES

### DEX ADAPTOR

A unique adaptor with two special knobs that can be fitted to different types of truss or other support structures, thereby creating the possibility to mount your stage DEX floor on several types of constructions. Mount the adaptor on the support structure and place the decks on the special knobs.

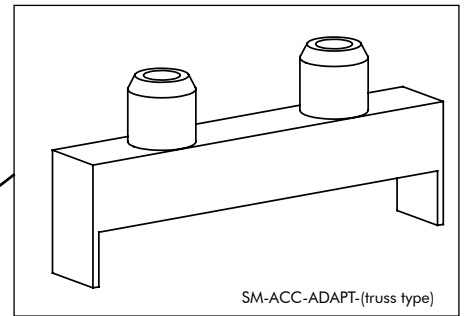
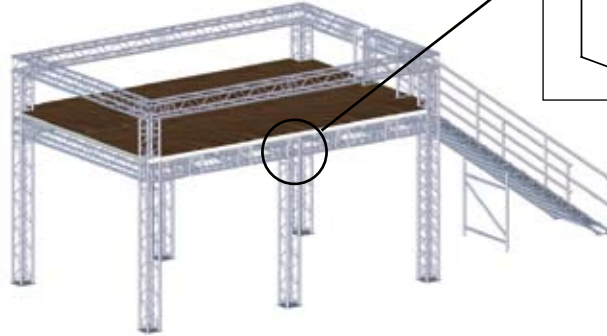

### COMBI-LEG ADAPTER

(SM-L-ACC-03/04)

The adapter mounts into the leg fitting on the one side and will slide into the leg on the other.

The SM-L-ACC-03 reduces 4 leg positions to 1 leg.

The SM-L-ACC-04 reduces 2 leg positions to 1 leg.

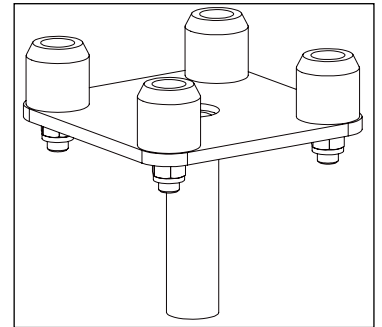
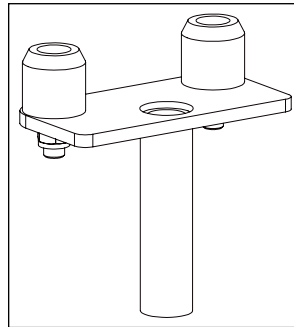

**PLEASE NOTE THAT USING THE COMBI-LEG ADAPTER SERIOUSLY REDUCES YOUR LOADING CAPACITY!**

### LEG-TO-LEG CLAMP

Apart from the SM-ACC-CLP-01, the leg-to-leg clamp that mounts on two legs, Prolyte has designed the SM-ACC-CLP-02, which mounts on four legs. Both clamps are easily mounted; tools are not necessary.

The clamps absorb the horizontal forces on the stage floor and guarantees a close fit of the decks.

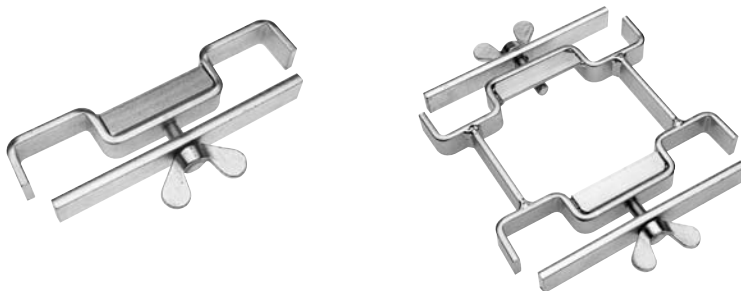

### DEX TO FRAME ADAPTER

In order to safely mount the decks to the Easy Fame B system, Prolyte has developed the DEX to Frame adapter. This adapter is mounted in the leg connection and prevents any horizontal movement of the stage decks.



(SM-F-B-ADAP-01)

**DEX-TO-DEX CLAMP**

(SM-ACC-CLP-03)

After your decks are mounted to the legs or support structure, they can be connected to each other by means of this clamp, thereby providing a sturdy connection between the decks.

Using the clamp will prevent any unwanted vertical movement of your stage floor and will absorb the horizontal loading applied to the decks.

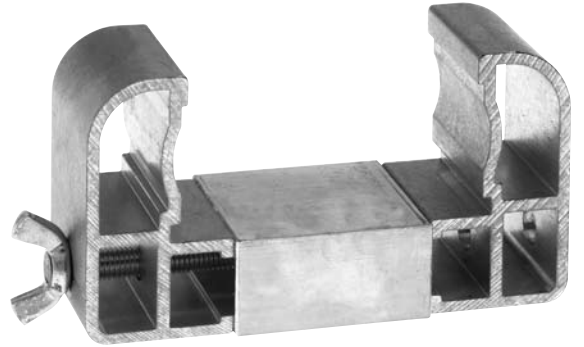

(SM-CT-ATT-01)

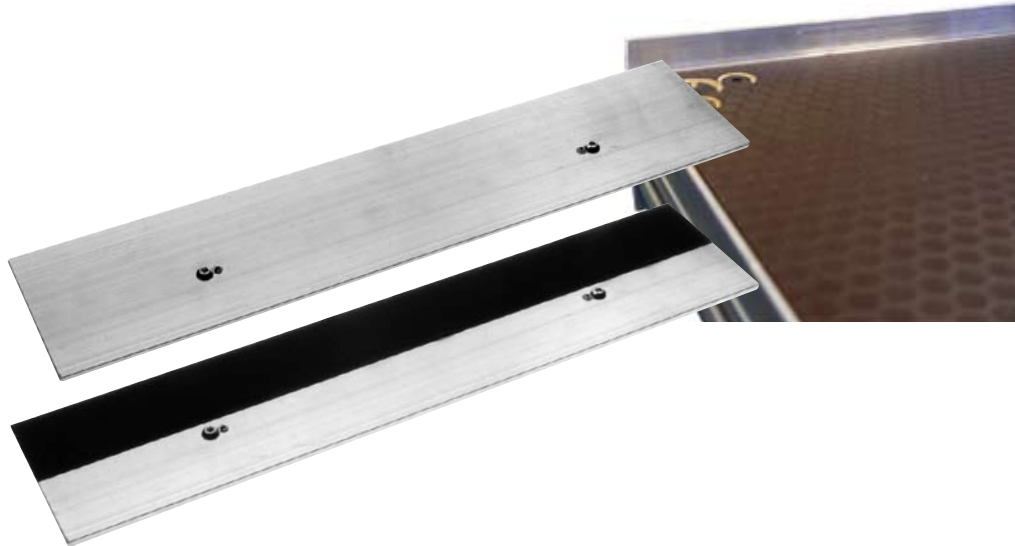

**CURTAIN PROFILE**

Prolyte has developed a profile that has a double function. It can act as toe board as well as skirting profile. The profile slides into the side of the deck and can be fixed in place if needed. The profile can be mounted in two positions; the topside is even with the deck or the topside protrudes about 20 mm above the deck, thereby creating a sufficient toe board. A Velcro strip is delivered with the profile and can be used to attach the curtains to the profile. The curtain profile is available in lengths of 470 mm, 970 mm and 1970 mm.

**CURTAINS**

Straight or pleated curtains for the curtain profile are available in several lengths of 2000 mm to 6000 mm and heights of 200 mm to 2000 mm.

**T-HEAD BOLT**

The T-head bolt can be placed in the side profile of the deck. The bolt can be used to attach anything that can be bolted in place, from panels and signs to set pieces to special accessories, etc. The bolts are available in several lengths.



(SM-SP-T-BOLT-40)



## **PROLYTE** PRODUCTS

### **PROLYTE PRODUCTS GROUP**

Industriepark 9 - NL-9351 PA Leek

tel.: +31 (0)594 85 15 15

fax: +31 (0)594 85 15 16

e-mail: [info@prolyte.com](mailto:info@prolyte.com)

website: [www.prolyte.com](http://www.prolyte.com)