

For Customer in China

根据中华人民共和国信息产业部第39号令《电子信息产品污染控制管理办法》及标准中要求的“有毒有害物质或元素名称及含量”等信息，本产品相关信息请参考以下链接：
<http://pro.sony.com.cn>

SONY®

4-164-464-11(1)

Solid-State Memory Camcorder

Operating Instructions

Before operating the unit, please read this manual thoroughly and retain it for future reference.

PMW-350K
PMW-350L

出版日期：2009年11月

Printed on recycled paper.

<http://www.sony.net/>
Printed in Japan

XDCM EX
CINEALTA

SXS
Exmor
FULL HD 3CMOS

i
HDMI

© 2009 Sony Corporation

WARNING

To reduce the risk of fire or electric shock, do not expose this apparatus to rain or moisture.

To avoid electrical shock, do not open the cabinet. Refer servicing to qualified personnel only.

Important Safety Instructions

- Read these instructions.
- Keep these instructions.
- Heed all warnings.
- Follow all instructions.
- Do not use this apparatus near water.
- Clean only with dry cloth.
- Do not block any ventilation openings. Install in accordance with the manufacturer's instructions.
- Do not install near any heat sources such as radiators, heat registers, stoves, or other apparatus (including amplifiers) that produce heat.
- Do not defeat the safety purpose of the polarized or grounding-type plug. A polarized plug has two blades with one wider than the other. A grounding-type plug has two blades and a third grounding prong. The wide blade or the third prong are provided for your safety. If the provided plug does not fit into your outlet, consult an electrician for replacement of the obsolete outlet.
- Protect the power cord from being walked on or pinched particularly at plugs, convenience receptacles, and the point where they exit from the apparatus.
- Only use attachments/accessories specified by the manufacturer.
- Refer all servicing to qualified service personnel. Servicing is required when the apparatus has been damaged in any way, such as power-supply cord or plug is damaged, liquid has been spilled or objects have fallen into the apparatus, the

apparatus has been exposed to rain or moisture, does not operate normally, or has been dropped.

WARNING

Excessive sound pressure from earphones and headphones can cause hearing loss. In order to use this product safely, avoid prolonged listening at excessive sound pressure levels.

For the customers in the U.S.A.

This equipment has been tested and found to comply with the limits for a Class A digital device, pursuant to Part 15 of the FCC Rules. These limits are designed to provide reasonable protection against harmful interference when the equipment is operated in a commercial environment. This equipment generates, uses, and can radiate radio frequency energy and, if not installed and used in accordance with the instruction manual, may cause harmful interference to radio communications. Operation of this equipment in a residential area is likely to cause harmful interference in which case the user will be required to correct the interference at his own expense.

You are cautioned that any changes or modifications not expressly approved in this manual could void your authority to operate this equipment.

All interface cables used to connect peripherals must be shielded in order to comply with the limits for a digital device pursuant to Subpart B of Part 15 of FCC Rules.

This device complies with Part 15 of the FCC Rules. Operation is subject to the following two conditions: (1) this device may not cause harmful interference, and (2) this device must accept any interference received, including interference that may cause undesired operation.

For the customers in Canada

This Class A digital apparatus complies with Canadian ICES-003.

For the customers in Europe

This product with the CE marking complies with the EMC Directive issued by the Commission of the European Community. Compliance with this directive implies conformity to the following European standards:

- EN55103-1: Electromagnetic Interference(Emission)
- EN55103-2: Electromagnetic Susceptibility(Immunity)

This product is intended for use in the following Electromagnetic Environments: E1 (residential), E2 (commercial and light industrial), E3 (urban outdoors), E4 (controlled EMC environment, ex. TV studio).

The manufacturer of this product is Sony Corporation, 1-7-1 Konan, Minato-ku, Tokyo, Japan.

The Authorized Representative for EMC and product safety is Sony Deutschland GmbH, Hedelfinger Strasse 61, 70327 Stuttgart, Germany.

For the State of California, USA only

Perchlorate Material - special handling may apply, See

www.dtsc.ca.gov/hazardouswaste/perchlorate

Perchlorate Material : Lithium battery contains perchlorate.

For the customers in Taiwan only



廢電池請回收

AVERTISSEMENT

Afin de réduire les risques d'incendie ou d'électrocution, ne pas exposer cet appareil à la pluie ou à l'humidité.

Afin d'écartier tout risque d'électrocution, garder le coffret fermé. Ne confier l'entretien de l'appareil qu'à un personnel qualifié.

AVERTISSEMENT

Une pression acoustique excessive en provenance des écouteurs ou du casque peut provoquer une baisse de l'acuité auditive.

Pour utiliser ce produit en toute sécurité, évitez l'écoute prolongée à des pressions sonores excessives

Pour les clients au Canada

Cet appareil numérique de la classe A est conforme à la norme NMB-003 du Canada.

Pour les clients en Europe

Ce produit portant la marque CE est conforme à la Directive sur la compatibilité électromagnétique (EMC) émise par la Commission de la Communauté européenne.

La conformité à cette directive implique la conformité aux normes européennes suivantes :

- EN55103-1 : Interférences électromagnétiques (émission)
- EN55103-2 : Sensibilité électromagnétique (immunité)

Ce produit est prévu pour être utilisé dans les environnements électromagnétiques suivants : E1 (résidentiel), E2 (commercial et industrie légère), E3 (urbain extérieur) et E4 (environnement EMC contrôlé, ex. studio de télévision).

Le fabricant de ce produit est Sony Corporation, 1-7-1 Konan, Minato-ku, Tokyo, Japon.

Le représentant autorisé pour EMC et la sécurité des produits est Sony Deutschland GmbH, Hedelfinger Strasse 61, 70327 Stuttgart, Allemagne.

WARNUNG

Um die Gefahr von Bränden oder elektrischen Schlägen zu verringern, darf dieses Gerät nicht Regen oder Feuchtigkeit ausgesetzt werden.

Um einen elektrischen Schlag zu vermeiden, darf das Gehäuse nicht geöffnet werden. Überlassen Sie Wartungsarbeiten stets nur qualifiziertem Fachpersonal.

WARNUNG

Zu hoher Schalldruck von Ohrhörern und Kopfhörern kann Gehörschäden verursachen.

Um dieses Produkt sicher zu verwenden, vermeiden Sie längeres Hören bei sehr hohen Schalldruckpegeln.

Für Kunden in Europa

Dieses Produkt besitzt die CE-Kennzeichnung und erfüllt die EMV-Richtlinie der EG-Kommission.

Angewandte Normen:

- EN55103-1: Elektromagnetische Verträglichkeit (Störaussendung)
- EN55103-2: Elektromagnetische Verträglichkeit (Störfestigkeit)

Für die folgenden elektromagnetischen Umgebungen: E1 (Wohnbereich), E2 (kommerzieller und in beschränktem Maße industrieller Bereich), E3 (Stadtbereich im

Freien) und E4 (kontrollierter EMV-Bereich, z.B. Fernsehstudio).

Der Hersteller dieses Produkts ist Sony Corporation, 1-7-1 Konan, Minato-ku, Tokyo, Japan.

Der autorisierte Repräsentant für EMV und Produktsicherheit ist Sony Deutschland GmbH, Hedelfinger Strasse 61, 70327 Stuttgart, Deutschland.

Table of Contents

Foreword	10
Before Use.....	10

Chapter 1 : Overview

Features	11
Using the CD-ROM	12
Reading the CD-ROM Manuals.....	12
System Requirements for Using the Applications	13
Software Installation	13
Locations and Functions of Parts and Controls.....	14
Power Supply	14
Accessory Attachments.....	14
Operating and Connectors Section.....	16
Monochrome LCD Panel	25
Auto Focus Lens (Supplied with the PMW-350K).....	26
Viewfinder.....	27
Viewfinder Screen Display.....	29

Chapter 2 : Preparations

Preparing a Power Supply	33
Using a Battery Pack.....	33
Using AC Power	34
Attaching the Viewfinder	35
Attaching the Supplied Viewfinder.....	35
Adjusting the Viewfinder Position.....	35
Adjusting the Viewfinder Angle	36
Lifting Up the Viewfinder Barrel and Eyepiece	36
Adjusting the Viewfinder Focus and Screen.....	37
Using the BKW-401 Viewfinder Rotation Bracket	37
Attaching a 5-inch Electronic Viewfinder	38
Setting the Area of Use	40
Setting the Date/Time of the Internal Clock	41
Mounting and Adjusting the Lens.....	41
Adjusting the Flange Focal Length.....	42

Preparing the Audio Input System	43
Connecting a Microphone to the MIC IN Connector.....	43
Connecting Microphones to the AUDIO IN Connectors.....	44
Attaching a UHF Portable Tuner (for a UHF Wireless Microphone System)	45
Tripod Mounting	46
Connecting a Video Light	47
Using the Shoulder Strap	48
Adjusting the Shoulder Pad Position	49

Chapter 3 : Adjustments and Settings

Setting the Video Format	50
Changing the Video Format	51
Adjusting the Black Balance and the White Balance	51
Adjusting the Black Balance	51
Adjusting the White Balance	52
Setting the Electronic Shutter.....	55
Shutter Modes	55
Selecting the Shutter Mode and Shutter Speed	55
Changing the Reference Value for Automatic Iris Adjustment	57
Zooming	58
Switching between Zoom Modes.....	58
Using Manual Zoom	58
Using Servo Zoom	58
Adjusting the Focus	58
Adjusting in Full MF Mode	58
Adjusting in MF Mode.....	59
Adjusting in AF Mode	59
Using Macro Mode	59
Adjusting the Audio Level	60
Manually Adjusting the Audio Levels of the Audio Inputs from the AUDIO IN CH1/CH2 Connectors.....	60
Manually Adjusting the Audio Level of the MIC IN Connector....	60
Recording Audio on Channels 3 and 4	61
Setting the Time Data.....	62
Setting the Timecode.....	62
Setting the User Bits.....	63
Synchronizing the Timecode.....	63

Checking Camcorder Settings and Status Information (Status Screens)	65
---	----

Chapter 4 : Shooting

Handling S×S Memory Cards.....	67
About S×S Memory Cards	67
Loading and Ejecting S×S Memory Cards	68
Selecting the S×S Memory Card to Use	69
Formatting (Initializing) S×S Memory Cards	69
Checking the Remaining Recording Time	70
Restoring S×S Memory Cards	70
Basic Operations	71
Playing Recorded Clips	72
Deleting Recorded Clips	73
Advanced Operations	73
Recording Shot Marks.....	73
Setting OK Marks	73
Starting to Record from Pre-stored Video (Picture Cache Function)	74
Recording Time-lapse Video (Interval Rec Function).....	75
Shooting Stop Motion Animations (Frame Rec Function)	77
Shooting with Slow & Quick Motion	78
Framing Shots with the Freeze Mix Function.....	79

Chapter 5 : Clip Operations

Clip Playback	80
Thumbnail Screen	80
Playing Clips	82
Using Thumbnails to Search Inside Clips	83
Thumbnail Operations	84
THUMBNAIL Menu Configuration	84
Basic THUMBNAIL Menu Operations	85
Changing the Thumbnail Screen Type.....	85
Displaying Clip Properties	86
Adding and Deleting OK Marks (HD Mode Only)	87
Copying Clips	87
Deleting Clips.....	88
Displaying the Expand Thumbnail Screen.....	88
Displaying the Shot Mark Thumbnail Screen (HD Mode Only)	89
Adding and Deleting Shot Marks (HD Mode Only).....	90
Changing Clip Index Pictures (HD Mode Only).....	90

Chapter 6 : Menu and Detailed Settings

Setup Menu Organization and Levels.....	92
Setup Menu Organization	92
Setup Menu Levels.....	92
Basic Setup Menu Operations	94
Menu List.....	96
OPERATION Menu.....	96
PAINT Menu.....	109
MAINTENANCE Menu	115
FILE Menu	127
Assigning Functions to Assignable Switches	131
Functions that can be assigned to the ASSIGN. 0 switch.....	131
Functions that can be assigned to the ASSIGN. 2 switch.....	132
Functions that can be assigned to the ASSIGN. 1 and 3 switches, the ASSIGNABLE 4 and 5 switches, and the COLOR TEMP. button	132
Functions that can be assigned to the RET button on the lens.....	134

Chapter 7 : Saving and Loading User Setting Data

Saving and Loading Settings.....	135
Saving Setting Data.....	135
Loading Setting Data.....	136
Resetting a File after Changing Its Contents.....	136
Saving and Loading Scene Files	137
Saving Scene Files	137
Loading Scene Files	137
Saving and Loading Lens Files.....	138
Setting Lens File Data.....	138
Saving Lens Files	138
Loading Lens Files	138
Loading Lens Files Automatically	139

Chapter 8 : Connecting External Devices

Connecting External Monitors	140
Operating Clips with a Computer.....	142

Connecting an External Device (i.LINK Connection).....	144
Recording the Camera Picture on an External Device.....	144
Nonlinear Editing	145
Recording External Input Signals	145

Chapter 9 : Maintenance

Testing the Camcorder	147
Maintenance	147
Cleaning the Viewfinder	147
Note about the Battery Terminal	147
Operation Warnings.....	148

Appendix

Important Notes on Operation	155
Exchanging the Battery of the Internal Clock	157
Specifications.....	157
General	157
Camera Block.....	158
Audio Block	158
Display	158
Media Block	158
Inputs/Outputs	159
Lens Block (PMW-350K only).....	159
Supplied Accessories	159
Recommended Additional Equipment	160
Chart of Optional Components and Accessories	162
About i.LINK	163
MPEG-2 Video Patent Portfolio License	164
Index.....	165

Foreword

Before Use

After purchasing the PMW-350K/350L Solid-State Memory Camcorder, before operating, it is necessary to set the area of use.

(Unless this setting is made, the camcorder will not operate.)

For details of these settings, see “Setting the Area of Use” (page 40).

Note

Before attaching/removing optional components or accessories to/from the PMW-350K/350L (referred to as “the camcorder”), be sure to turn the power of the camcorder off.

Chapter 1 Overview

Features

$2/3$ -type full-HD (1920 × 1080) CMOS image sensors

The PMW-350K/350L Solid-State Memory Camcorder is provided with three newly developed $2/3$ -type “Exmor” CMOS image sensors with approximately 207 million effective pixels, for full HD resolution (1920 × 1080). The new image sensor technology enables the capture of very high-quality images, with a sensitivity of F12 (59.94i) / F13 (50i) and an SN ratio of 59 dB.

S×S memory cards as recording media

Using S×S memory cards, the camcorder offers nonlinear capabilities such as instant random access and file-based operation.

Light weight, low power consumption

Design features such as CMOS image sensors, custom video signal processing ICs, and S×S memory card recording enable fanless operation and power consumption of 15 W or less. The camcorder’s light weight (3.2 kg (7 lb 0.88 oz)) and low center of gravity make it easy to carry on the shoulder while ensuring superior stability.

HD recording using the “MPEG-2 Long GOP” codec

The camcorder records 1920 × 1080, 1440 × 1080, and 1280 × 720 HD images using “MPEG-2 Long GOP” codec compression. It offers a choice of bit rates: either 35 Mbps (HQ mode) or 25 Mbps (SP mode).

By utilizing an efficient compression format, the camcorder records high-quality HD images for long recording time of approx. 100 minutes at 35 Mbps (HQ mode) or approx. 140 minutes at 25

Mbps (SP mode) on a single 32-GB S×S memory card.

Multi-format support

The camcorder supports interlace format recording (1080/59.94i or 1080/50i), progressive format recording (1080/29.97P, 1080/23.98P, 720/59.94P, 720/29.97P, 720/23.98P, or 1080/25P, 720/50P, 720/25P), thus offering the flexibility needed for worldwide HD recording. (For 23.98P, native frequency recording is possible.)

It also supports recording and playback of SD signals (both NTSC and PAL). The camcorder has an optional capability to record and play back SD signals in DVCAM-AVI format (option ¹⁾), and can output HD signals down-converted to SD.

1) CBK-DV01

A special auto focus lens

The camcorder is provided with the $2/3$ -type auto focus lens, which ensures high-quality shooting in all situations from wide angle to telephoto (PMW-350K only).

A variety of functions for improved performance under various shooting conditions

- Picture Cache function
- Optical ND filters and electrical CC filters
- Hyper gamma
- Slow shutter function
- Frame Recording function
- Time lapse function (interval recording)
- Slow & quick motion function
- Freeze mix function
- Focus magnification function
- Image inversion function
- Assignable switches
- 3.5-inch high-resolutin color LCD viewfinder
- Remote control

Inherits unique features of XDCAM EX series

The camcorder inherits the workflow features of the XDCAM EX series, including thumbnail display and metadata management, and improves them by introducing an improved man-machine interface.

XDCAM EX web sites

For information on XDCAM EX, visit the following web sites:

United States

<http://www.sony.com/xdcamex>

Canada

<http://www.sony.ca/xdcamex>

Europe, Middle East, Africa, and Russia

<http://www.sonybiz.net/xdcamex>

Latin America

<http://www.sonypro-latin.com/xdcamex>

Australia

<http://www.sony.com.au/xdcamex>

Asia (except Korea, China, and Japan)

<http://pro.sony-asia.com>

Korea

<http://bp.sony.co.kr/xdcamex>

China

<http://pro.sony.com.cn/minisite/XDCAMEX>

Japan

<http://www.sony.co.jp/XDCAMEX>

Using the CD-ROM

Two CD-ROMs are supplied with the camcorder. The CD-ROM labeled “Manuals for Solid-State Memory Camcorder” contains the PDF files of the Operating Instructions and Supplement for the camcorder (Japanese, English, French, German, Italian, Spanish and Chinese).

The CD-ROM labeled “Utility Software for Solid-State Memory Camcorder and Recorder” contains the following software:

S×S Device Driver Software

Driver for using S×S memory cards with a computer having an ExpressCard slot. Information on installation of the software is included in the ReadMe (Japanese, English, French, German, Italian, Spanish, and Chinese) in PDF format.

XDCAM EX Clip Browsing Software

Application program for operating clips recorded with XDCAM EX-series models on a computer. Information on installation and operations of the software is included in the User’s Guide (Japanese, English, French, German, Italian, Spanish, and Chinese) in PDF format.

Reading the CD-ROM Manuals

Preparations

The following program must be installed on your computer in order to read the operation manuals contained on the CD-ROM.

Adobe Reader Version 6.0 or higher

Memo

If Adobe Reader is not installed, you can download it from the following URL:

<http://www.adobe.com/>

Adobe and Adobe Reader are trademarks of Adobe Systems Incorporated in the United States and/or other countries.

To read the documents

Do the following:

1 Insert the CD-ROM in your CD-ROM drive.

A cover page appears automatically in your browser.

If it does not appear automatically in the browser, double-click on the index.htm file on the CD-ROM.

2 Select and click on the manual that you wish to read.

This opens the PDF file.

Memo

The files may not be displayed properly, depending on the version of Adobe Reader. In such a case, install the latest version you can download from the URL mentioned in “Preparations” above.

Note

If you have lost or damaged the CD-ROM, you can purchase a new one to replace it. Contact a Sony service representative.

System Requirements for Using the Applications

The following operating conditions are recommended for using the software recorded on the CD-ROM:

S×S Device Driver Software

Applicable hardware

Computer conforming to ExpressCard/34 or ExpressCard/54

OS

Microsoft Windows XP SP2 or later, Microsoft Windows Vista, Microsoft Windows 7, or Mac OS X v10.4.9 or later

For support information on the driver, refer to the following URL:

<http://www.sony.net/S×S-Support/>

XDCAM EX Clip Browsing Software

For the operating requirements, visit the web sites shown in “XDCAM EX web sites” (page 12) or

refer to the User’s Guide contained in the CD-ROM.

Software Installation

Do the following to install the software on the CD-ROM on your computer:

1 Insert the CD-ROM in your CD-ROM drive.

A cover page appears automatically in your browser.

If it does not appear automatically in the browser, double-click on the index.htm file on the CD-ROM.

2 Select and click on the software that you wish to install.

The installer for the software starts up.

Follow the displayed instructions:

For details, refer to the User’s Guide or ReadMe of the software.

Uninstalling an application program

Windows computer

Choose “Start,” “Control Panel” then “Add or Remove Programs” and specify the program to be deleted.

Macintosh computer

Drop the folder of the software (default: /Application/XDCAM EX Clip Browser) into Trash.

Locations and Functions of Parts and Controls

Power Supply

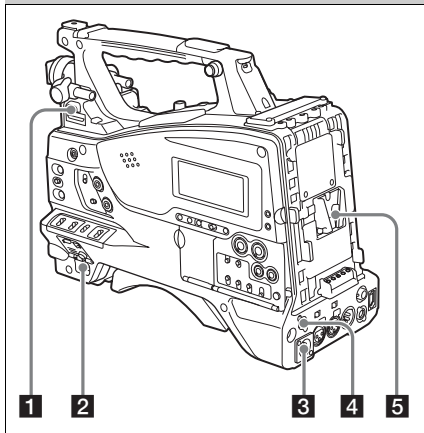

1 LIGHT switch

Determines how a video light connected to the LIGHT connector (*see page 15*) is turned on and off.

AUTO: When the POWER switch of the video light is in the on position, the video light is turned on automatically while the camcorder is recording.

MANUAL: You can turn the video light on or off manually, using its own switch.

Note

When the camcorder is set for recording in Picture Cache mode, it is not possible to turn on the light before operation to start recording is carried out (or while data is being stored in memory).

2 POWER switch

Turns the main power supply on and off.

3 DC IN (DC power input) connector (XLR type, 4-pin, male)

To operate the camcorder from an AC power supply, connect an optional DC power cord to this terminal and then connect the cord to the DC output terminal of the BC-L70, BC-M150, or another battery charger.

4 DC OUT 12V (DC power output) connector (4-pin, female)

Supplies power for an optional WRR-860A/861/862 UHF Synthesized Diversity Tuner (maximum 0.5 A).

Do not connect any equipment other than the UHF synthesized diversity tuner.

5 Battery attachment shoe

Attach a BP-GL95/GL65/L80S/L60S Battery Pack. Alternatively, you can attach an AC-DN2B/DN10 AC Adaptor to operate the camcorder on AC power supply.

For details, see "Preparing a Power Supply" (page 33).

For details, see "Attaching a UHF Portable Tuner (for a UHF Wireless Microphone System)" (page 45).

Note

For your safety, and to ensure proper operation of the camcorder, Sony recommends the use of the following battery packs: BP-GL95, BP-GL65, BP-L60S, and BP-L80S.

Accessory Attachments

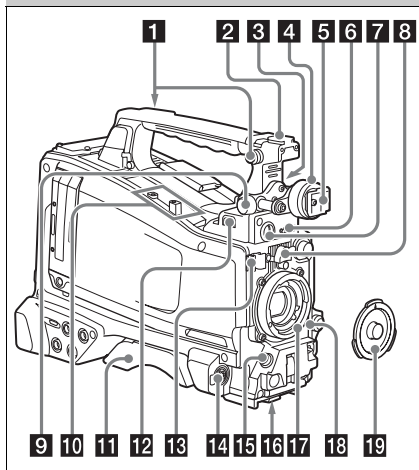

1 Shoulder strap fitting

Attach the supplied shoulder strap (*see page 48*).

2 Light fitting shoe

Attach an optional accessory such as a video light (*see page 47*).

3 Viewfinder front-to-back positioning lever

To adjust the viewfinder position in the front-to-back direction, loosen this lever and the LOCK knob. After adjustment, retighten this lever and the LOCK knob.

4 Viewfinder left-to-right positioning ring

Loosen this ring to adjust the left-to-right position of the viewfinder (*see page 35*).

5 Viewfinder fitting shoe

Attach the viewfinder.

6 VF (viewfinder) connector (26-pin, rectangular)

Connect the cable of the supplied viewfinder.

7 VF (viewfinder) connector (20-pin, round)

Connect the cable of the optional DXF-51 or DXF-20W viewfinder.

For connecting the DXF-51, optional parts are required. Consult a Sony service representative for information about connecting the DXF-51.

8 Lens mount securing rubber

After locking the lens in position using the lens locking lever, fit this rubber over the lower of the two projections. This fixes the lens mount, preventing it from coming loose.

9 Viewfinder front-to-back positioning knob (LOCK knob)

Loosen this knob to adjust the front-to-back position of the viewfinder (*see page 35*).

10 Fitting for optional microphone holder

Fit an optional CAC-12 Microphone Holder (*see page 44*).

11 Shoulder pad

Raise the shoulder pad fixing lever to adjust the position in the front-to-rear direction. Adjust the position for maximum convenience when operating the camcorder on your shoulder (*see page 49*).

12 LIGHT (video light) connector (2-pin, female)

A video light with a maximum power consumption of 50 W, such as the Anton Bauer Ultralight 2 or equivalent can be connected (*see page 47*).

13 Lens cable clamp

Clamp a lens cable.

14 MIC IN (microphone input) (+48 V) connector (XLR type, 5-pin, female)

Connect a stereo microphone to this connector. The power (+48 V) is supplied via this connector.

15 LENS connector (12-pin)

Connect a lens cable to this connector.

Note

When connecting or disconnecting the lens cable to this connector, power off the camcorder first.

16 Tripod mount

When using the camcorder on a tripod, attach the tripod adaptor (optional).

17 Lens mount (special bayonet mount)

Attach the lens.

Consult a Sony service representative for information about available lenses.

18 Lens locking lever

After inserting the lens in the lens mount, rotate the lens mount ring with this lever to lock the lens in position.

After locking the lens, be sure to use the lens mount securing rubber to prevent the lens from becoming detached.

19 Lens mount cap

Remove by pushing up the lens locking lever. When no lens is mounted, keep this cap fitted for protection from dust.

Operating and Connectors Section

Front

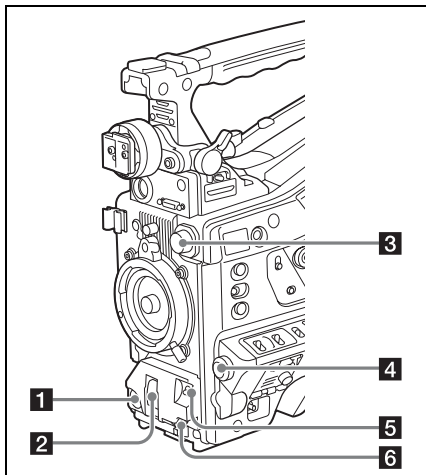

1 REC START (recording start) button

Press to start recording. Press it again to stop recording. The effect is the same as that of the REC button on the lens.

2 SHUTTER selector

Set to ON to use the electronic shutter. Push to SELECT to switch the shutter speed or shutter mode setting. When this switch is operated, the new setting appears on the viewfinder screen for about three seconds.

For details, see “Setting the Electronic Shutter” (page 55).

3 FILTER selector

Switches between four ND filters built into this camcorder.

When this selector is used, the new setting appears on the viewfinder screen for about three seconds.

FILTER selector setting	ND filter
1	CLEAR
2	$1/4$ ND (attenuates light to approximately $1/4$)
3	$1/16$ ND (attenuates light to approximately $1/16$)

You can change a MAINTENANCE menu setting so that different white balance settings can be stored for different FILTER selector positions. This allows you to automatically obtain optimum white balance for the current shooting conditions in linkage with the filter selection.

For details, see “Adjusting the White Balance” (page 52).

4 MENU knob

Changes the item selection or a setting within the menu (*see page 94*).

5 AUTO W/B BAL (automatic white/black balance adjustment) switch

Activates the automatic white/black balance adjustment functions.

WHITE: Adjust the white balance automatically.

If the WHITE BAL switch (*see page 18*) is set to A or B, the white balance setting is stored in the corresponding memory. If the WHITE BAL switch is set to PRST, the automatic white balance adjustment function does not operate.

BLACK: Adjust the black set and black balance automatically.

You can use the AUTO W/B BAL switch even when the ATW (Auto Tracing White Balance) function is operating.

If you push the switch to the WHITE side once more during the automatic white balance adjustment, the adjustment is cancelled and the white balance setting returns to the original setting.

If you push the switch to the BLACK side once more during the automatic black balance adjustment, the adjustment is cancelled and the black balance setting returns to the original setting.

6 MIC (microphone) LEVEL control

Adjusts the input level of audio channels 1, 2, 3 and 4 (*see page 60*).

Right side (near the front)

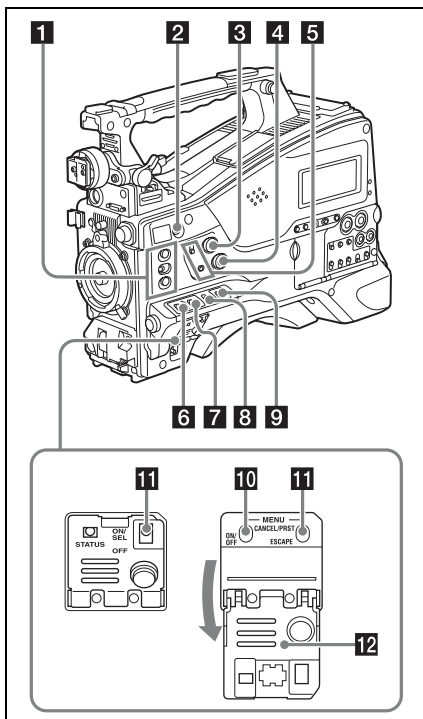

1 ASSIGN. (assignable) 1/2/3 switches

You can assign the desired functions to these switches on OPERATION > Assignable SW in the setup menu (see page 131). EZ Mode is assigned to the ASSIGN. 1 switch, and Off is assigned to the ASSIGN. 2/3 switches as the factory default setting.

The ASSIGN.1/3 switches are provided with an indicator to show whether a function is assigned to the switch (ON) or not (OFF).

2 COLOR TEMP. (color temperature) button

Press to light the button and change the color temperature for shooting (factory default setting). You can use this as an assignable switch (see page 131).

3 ALARM (alarm tone volume adjustment) knob

Controls the volume of the warning tone that is output via the built-in speaker or optional earphones. When the knob is turned to the minimum position, no sound can be heard. However, if MAINTENANCE > Audio > Min Alarm Volume in the setup menu is set to [Set], the alarm tone is audible even when this volume control is at the minimum position.

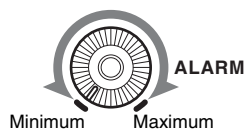

4 MONITOR (monitor volume adjustment) knob

Controls the volume of the sound other than the warning tone that is output via the built-in speaker or earphones. When the knob is turned to the minimum position, no sound can be heard.

5 MONITOR (audio monitor selection) switches

By means of combinations of the two switches, you can select audio that you want to hear through the built-in speaker or earphones.

Position of down-side switch: CH-1/2

Position of up-side switch	Audio output
CH-1/CH-3	Channel 1 audio
MIX	Channels 1 and 2 mixed audio (stereo) ^{a)}
CH-2/CH-4	Channel 2 audio

Position of down-side switch: CH-3/4

Position of up-side switch	Audio output
CH-1/CH-3	Channel 3 audio
MIX	Channels 3 and 4 mixed audio (stereo) ^{a)}
CH-2/CH-4	Channel 4 audio

a) By connecting stereo headphones to the EARPHONE jack, you can hear the audio in stereo. (Under MAINTENANCE > Audio in the setup menu, Headphone Out must be set to STEREO.)

6 ASSIGN. (assignable) 0 switch

You can assign the desired function to this switch on OPERATION >Assign SW in the setup menu (see page 132).

Off is assigned to this switch when the camcorder is shipped from the factory.

This is a momentary type switch. Each press of the switch turns the function assigned to this switch on or off.

7 GAIN selector

Switches the gain of the video amplifier to match the lighting conditions during shooting. The gains corresponding to the L, M, and H settings can be selected on OPERATION >Gain Switch in the setup menu (see page 104). (The factory settings are L=0 dB, M=6 dB, and H=12 dB.)

When this switch is adjusted, the new setting appears on the viewfinder screen for about three seconds.

8 OUTPUT/DCC (output signal/dynamic contrast control) switch

Switches the video signal output from the camera module, between the following two.

BARS: Output the color bar signal.

CAM: Output the video signal being shot. When this is selected, you can switch DCC¹⁾ on and off.

1) **DCC (Dynamic Contrast Control):** Against a very bright background with the iris opening adjusted to the subject, objects in the background will be lost in the glare. The DCC function will suppress the high intensity and restore much of the lost detail and is particularly effective in the following cases.

- Shooting people in the shade on a sunny day
- Shooting a subject indoors, against a background through a window
- Any high contrast scene

9 WHITE BAL (white balance memory) switch

Controls adjustment of the white balance.

PRST: Adjust the color temperature to the preset value (the factory default setting: 3200K).

Use this setting when you have no time to adjust the white balance.

A or B: Recall the white balance adjustment settings already stored in A or B. Push the AUTO W/B BAL switch (see page 16) on the WHITE side, to automatically adjust the white balance, and save the adjustment

settings in memory A or memory B.

B (ATW¹⁾): When this switch is set to B and OPERATION >White Setting >White Switch is set to [ATW] in the setup menu, ATW is activated.

You can use the AUTO W/B BAL switch even when ATW is in use.

When this switch is adjusted, the new setting appears on the viewfinder screen for about three seconds.

1) **ATW (Auto Tracing White Balance):** The white balance of the picture being shot is adjusted automatically for varying lighting conditions.

10 MENU ON/OFF switch

To use this switch, open the cover.

This switch is used to display the menu on the viewfinder screen or the test signal screen. Each time the switch is pushed down, the menu screen is turned on and off.

The function of this switch is the same as that of the MENU button in the thumbnail screen operations section.

**11 STATUS ON/SEL/OFF (menu display on/page selection/display off) switch
MENU CANCEL/PRST (preset) /
ESCAPE switch**

When the menu is not displayed, this switch functions as the STATUS ON/SEL/OFF switch. When the menu is displayed, the switch functions as the MENU CANCEL/PRST/ESCAPE switch. (To use the MENU CANCEL/PRST/ESCAPE switch, open the cover.)

Use the STATUS ON/SEL/OFF switch in the following way.

ON/SEL: Each time this switch is pushed upward, a window to confirm the menu settings and status of the camcorder appears on the viewfinder screen (see page 65). The window consists of five pages, which are switched each time the switch is pushed upward. Each page is displayed for about 10 seconds.

OFF: To clear the page immediately after display, push this switch down to the OFF position.

Use the MENU CANCEL/PRST/ESCAPE in the following way.

CANCEL/PRST: Pushing this switch up to this position after a setting is changed in the setup menu displays the message to confirm whether the previous settings are cancelled. Pushing this switch up to this position again cancels the previous settings.

Pushing this switch up to this position before a setting is changed in the setup menu or after a setting change is cancelled in the setup menu displays the message to confirm whether the setting is reset to the initial value.

Pushing this switch up to this position again resets the settings to the initial value.

ESCAPE: Use this switch when the menu page, which has a hierarchical structure, is opened. Each time the switch is pushed to this position, the page returns to one stage higher in the hierarchy.

12 Cover

Open this cover to use the MENU ON/OFF switch or the MENU CANCEL/PRST/ESCAPE switch.

Right side (near the rear)

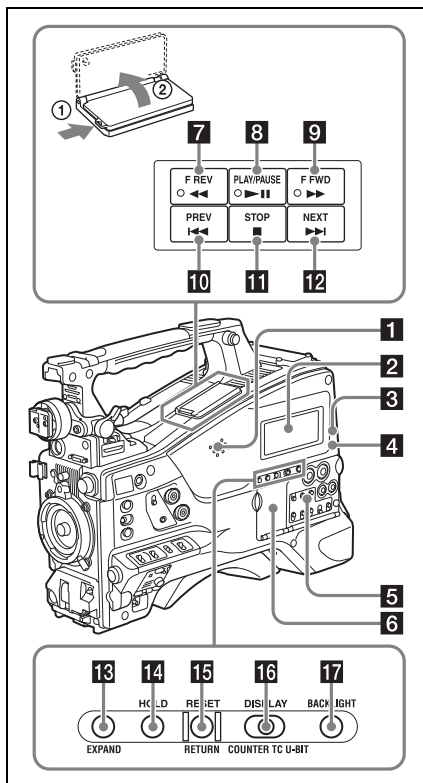

1 Built-in speaker

The speaker can be used to monitor E-E¹⁾ sound during recording, and playback sound during playback. The speaker also sounds alarms to reinforce visual warnings (*see page 148*).

If you connect earphones to the EARPHONE jack, the speaker output is suppressed automatically.

1) **E-E:** Abbreviation of “Electric-to-Electric”. In E-E mode, video and audio signals input to the camcorder are output after passing through internal electric circuits only. This can be used to check input signals.

2 Monochrome LCD panel

Displays remaining battery capacity, remaining media capacity, audio levels, time data, and so on (*see page 25*).

3 WARNING indicator

Lights up or flashes when an abnormality occurs (*see page 148*).

4 ACCESS lamp

Lights up when data is written to or read from the recording media.

5 Protection cover of the audio control section

Open to access the audio control section (*see page 21*).

6 Protection cover of the thumbnail screen operations section

Open to access the thumbnail screen operations section (*see page 21*).

7 F REV (fast reverse) button and indicator

This plays back at high speed in the reverse direction. The playback speed changes in the order $\times 4 \rightarrow \times 15 \rightarrow \times 24$ with each press of the button. The indicator lights during high-speed playback in the reverse direction.

8 PLAY/PAUSE button and indicator

Press this button to view play back video images using the viewfinder screen or the LCD monitor. The indicator lights during playback.

Press this button again during playback to pause, outputting a still image. At this time the indicator flashes at a rate of once per second.

Pressing the F REV or F FWD button during playback or pause starts high speed playback in the forward or reverse direction.

9 F FWD (fast forward) button and indicator

This plays back at high speed in the forward direction. The playback speed changes in the order $\times 4 \rightarrow \times 15 \rightarrow \times 24$ with each press of the button. The indicator lights during high-speed playback in the forward direction.

10 PREV button

This jumps to the first frame of the current clip. If you press this together with the F REV button, the jump is to the first frame of the first recorded clip on the recording media.

If you press this button twice in rapid succession, the jump is to the first frame of the last preceding

clip (or the first frame of the current clip when no preceding clips exist).

11 STOP button

Press this button to stop playback.

12 NEXT button

This jumps to the first frame of the next clip. If you press this together with the F FWD button, the jump is to the first frame of the last recorded clip on the recording media.

13 EXPAND (expand function) button

If you press this button when the thumbnail screen is displayed, the duration of the selected clip is divided into fractions, and the first frame of each of the divisions is shown in a further thumbnail display (expand function). For an HD recorded MP4 clip, its duration is divided into 12. If an SD recorded AVI clip comprises multiple files, the divisions are displayed for the individual files.

For MP4 clips, each time you press this button the division is repeated. Hold down the SHIFT button and press this button to step back through the division process.

14 HOLD (display hold) button

Pressing this button instantly freezes the time data displayed in the monochrome LCD panel. (The timecode generator continues running.) Pressing this button again releases the hold.

For details of the counter display, see page 25.

15 RESET/RETURN button

Resets the value shown in the time counter display in the monochrome LCD panel. According to the settings of the PRESET/REGEN/CLOCK switch (*see page 22*) and the F-RUN/SET/R-RUN switch (*see page 21*), this button resets the display as follows.

Settings of switches	To reset
DISPLAY switch: COUNTER	Counter to 0:00:00:00
DISPLAY switch: TC	Timecode to 00:00:00:00
PRESET/REGEN/ CLOCK switch: PRESET	
F-RUN/SET/R-RUN switch: SET	

Settings of switches	To reset
DISPLAY switch:	User bits data ^{a)} to 00 00 00
U-BIT	00
PRESET/REGEN/ CLOCK switch:	
PRESET	
F-RUN/SET/R-RUN switch: SET	

- a) Of the timecode bits for every frame recorded on the media, those bits which can be used to record useful information for the user such as scene number, shooting place, etc.

For details, see "Setting the Time Data" (page 62).

This button returns to the previous screen when pressed during thumbnail screen display, expand thumbnail screen display, or shot mark thumbnail screen display.

16 DISPLAY switch

This cycles the data displayed in the time counter display in the monochrome LCD panel through the sequence COUNTER, TC, and U-BIT (see page 25).

COUNTER: Display the elapsed recording/playback time (hours, minutes, seconds, frames).

TC: Display timecode.

U-BIT: Display user bits data.

17 BACKLIGHT button

Turns the backlight of the monochrome LCD on and off. The backlight of the monochrome LCD panel will be turned on when the camcorder is powered on for the first time after shipped from the factory.

Thumbnail screen operations section and audio control section

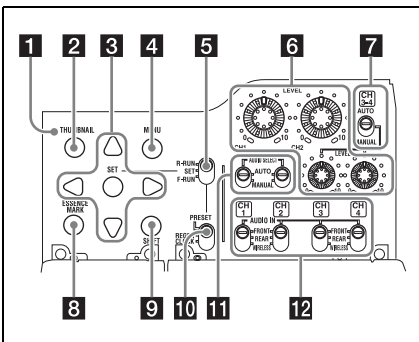

1 THUMBNAIL indicator

This lights when thumbnail screen is displayed.

2 THUMBNAIL button

Press this button to display the thumbnail screen (see page 80) and to carry out a thumbnail operation.

Press once more to return to the original display.

3 SET (set) button and arrow buttons

Use these buttons to make timecode and user bit settings, and for thumbnail screen operations (see page 85).

When the menu is displayed, press this button to select an item or to confirm the setting change.

4 MENU button

Each press of this button turns the setup menu display on and off.

The function of this button is the same as that of the MENU ON/OFF switch.

5 F-RUN/SET/R-RUN (free run/set/recording run) switch

Selects the operating mode of the internal timecode generator. The operating mode is set as explained below, depending on the position of the switch.

F-RUN: Timecode keeps advancing, regardless of whether the camcorder is recording. Use this setting when synchronizing the timecode with external timecode.

SET: Sets the timecode or user bits.

R-RUN: Timecode advances only during recording. Use this setting to have a consecutive timecode on the recording media.

For details, see “Setting the Timecode” (page 62) and “Setting the User Bits” (page 63).

6 LEVEL CH-1/CH-2/CH-3/CH-4 (audio channel 1/2/3/4 recording level) knobs

Adjust the audio levels to be recorded on channels 1, 2, 3, and 4 when the AUDIO SELECT CH-1/CH-2 and AUDIO SELECT CH 3-4 switches are set to MANUAL.

7 AUDIO SELECT CH 3-4 (audio channel 3/4 adjustment method selection) switch

Select the audio level adjustment method for each of audio channels 3 and 4.

AUTO: Automatic adjustment

MANUAL: Manual adjustment

8 ESSENCE MARK button

By pressing this button when the thumbnail display of a clip is on the screen, you can view the following thumbnail display of the shot-marked frames of that clip, depending on the item selected in a list displayed on the screen.

Shot Mark1: Thumbnail display of the frames marked with Shot Mark 1

Shot Mark2: Thumbnail display of the frames marked with Shot Mark 2

Shot Mark: Thumbnail display of the frames marked with either Shot Mark 1 or Shot Mark 2

9 SHIFT button

Use this in combination with other buttons.

10 PRESET/REGEN (regeneration)/CLOCK switch

Selects the type of timecode to record.

PRESET: Record new timecode on the media.

REGEN: Record timecode continuous with the existing timecode recorded on the media.

Regardless of the setting of the F-RUN/SET/R-RUN switch, the camcorder operates in R-RUN mode.

CLOCK: Record timecode synchronized to the internal clock. Regardless of the setting of the F-RUN/SET/R-RUN switch, the camcorder operates in F-RUN mode.

11 AUDIO SELECT CH-1/CH-2 (audio channel 1/2 adjustment method selection) switches

Select the audio level adjustment method for each of audio channels 1 and 2.

AUTO: Automatic adjustment

MANUAL: Manual adjustment

12 AUDIO IN CH-1/CH-2/CH-3/CH-4 (audio channel 1/2/3/4 input selection) switches

Select the audio input signals to be recorded on audio channels 1, 2, 3 and 4.

FRONT: Audio input signals from the microphone connected to the MIC IN connector

REAR: Audio input signals from an audio device connected to the AUDIO IN CH1/CH2 connectors

WIRELESS: Audio input signals from the UHF portable tuner if it is installed

Left side and upper section

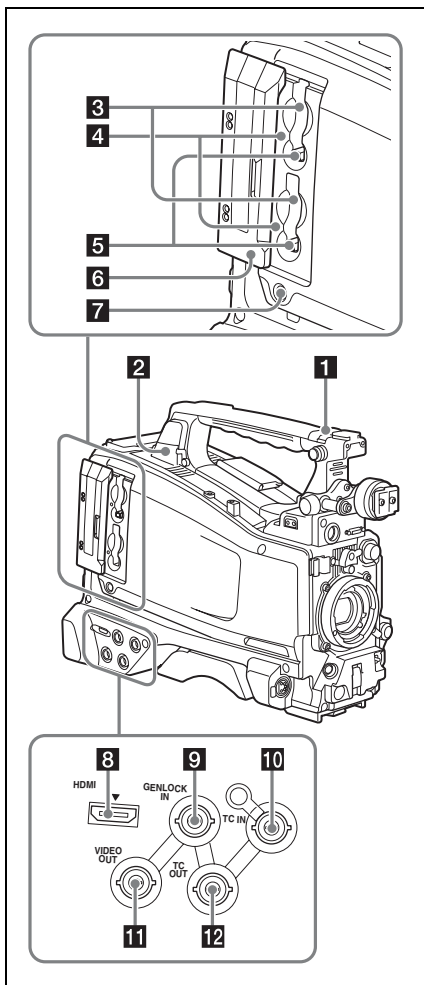

1 ASSIGNABLE 4/5 switches

You can assign the desired functions to these switches on OPERATION > Assignable SW in the setup menu (see page 132).

Off is assigned to these switches when the camcorder is shipped from the factory.

2 USB connector

Used to put this camcorder into USB connection mode and use it as an external storage device for a computer. When a computer without ExpressCard slot is connected to this connector, every memory card inserted in the camcorder is recognized as a drive for that computer.

3 SxS memory card slots

These two slots (A and B) can receive SxS memory cards or other recording media (see page 68).

4 ACCESS lamps

Indicate the state of slots A and B (see page 68). You can check whether the lamps are lit even when the slot cover is closed.

5 EJECT buttons

To remove the recording media from the slot, press the EJECT button to release the lock, then press the button once more. This makes the media come out of the slot partially (see page 69).

6 Slot cover

Slide to the left and right to open and close.

7 SLOT SELECT (SxS memory card select) button

When SxS memory cards are loaded in both card slots A and B, press this button to select the card you want to use (see page 69).

8 HDMI output connector

Outputs HDMI signals for video monitoring. When a video monitor provided with an HDMI signal input connector is connected to this connector, you can monitor picture being shot (camera picture) or playback picture.

9 GENLOCK IN (genlock signal input) connector (BNC type)

This connector inputs a reference signal when the camcorder is to be genlocked or when timecode is to be synchronized with external equipment. (Genlock for the camera module supports horizontal sync signals only.) Use MAINTENANCE > GENLOCK in the setup menu to adjust the genlock H-phase (phase of horizontal sync signal).

10 TC IN (timecode input) connector (BNC type)

To apply an external lock to the timecode of the camcorder, input the reference timecode.

For details, see “Setting the Timecode” (page 62).

11 VIDEO OUT connector (BNC type)

Outputs video signals for monitoring. The output signals can be selected either composite video or HD-Y depending on the setting of OPERATION >Input/Output >Output&i.LINK in the setup menu.

12 TC OUT (timecode output) connector (BNC type)

To lock the timecode of an external VTR to the timecode of this camcorder, connect this connector to the external VTR’s timecode input connector.

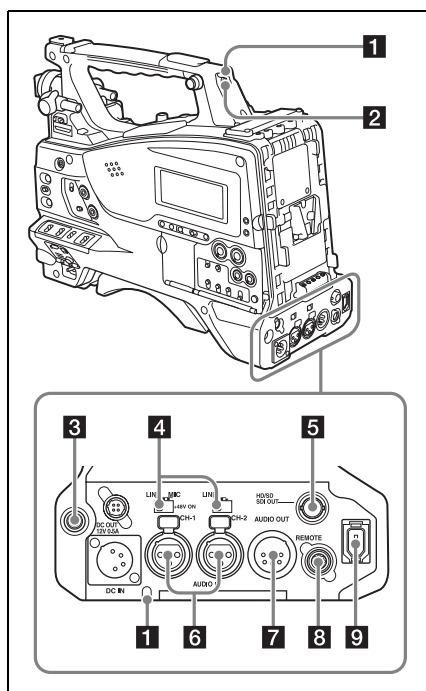
Rear**1 TALLY (back tally) indicators (red)**

Light up during recording. They will not light if the TALLY switch is set to OFF. These indicators also flash to indicate warnings (see page 20). The tally indicator on the front of the viewfinder and the REC indication on the viewfinder screen light or flash in the same manner.

For details, see “Operation Warnings” (page 148).

2 TALLY switch

Set to ON to activate the TALLY indicator function.

3 EARPHONE jack (stereo, minijack)

You can monitor the E-E sound during recording and playback sound during playback. When an alarm is indicated, you can hear the alarm sound through the earphone. Plugging an earphone into the jack automatically cuts off the built-in speaker.

You can select monaural or stereo on MAINTENANCE >Audio in the setup menu.

4 AUDIO IN selectors

Select the audio source you connect to the AUDIO IN CH1/CH2 connectors.

LINE: When connecting a stereo amplifier or other external audio signal source

MIC: When connecting a microphone that does not require 48 V power supply

+48V: When connecting a microphone that requires 48 V power supply

5 HD/SD SDI OUT connector (BNC type)

Outputs an HD SDI or SD SDI signal (with embedded audio). The output from this connector can be turned on and off with OPERATION >Input/Output >SDI Output in the setup menu.

6 AUDIO IN CH1/CH2 (audio channel 1 and channel 2 input) connectors (XLR type, 3-pin, female)

These are audio input connectors for channels 1 and 2 to which you can connect audio equipment or a microphone.

7 AUDIO OUT connector (XLR type, 5-pin, male)

Outputs the audio signals recorded on audio channels 1 and 2 or audio channels 3 and 4. The audio signals are selected by the MONITOR switch.

8 REMOTE connector (8-pin)

Connect a remote control unit, which makes it possible to control the camcorder remotely.

Note

Before connecting/disconnecting the Remote Control Unit to/from the camcorder, be sure to turn off the camcorder POWER switch.

9 i.LINK (HDV/DV) connector (6-pin, IEEE1394 compliant, S400)

To input and output HDV/DV streams, connect to an HDV/DV device.



The three dots indicates that timecode is displayed in the hold mode.

4 HOLD indication

Appears when the timecode generator output is displayed in the hold mode.

5 Audio level indicators

Indicate the audio recording or playback levels of channels 1 to 4.

6 Lock icon

Appears when the recording media is write-protected.

7 Remaining media capacity indicator

Shows bar segments indicating the remaining capacity of recording media in the slots.

8 Remaining battery capacity indicator

Shows bar segments indicating the remaining battery capacity.

Monochrome LCD Panel

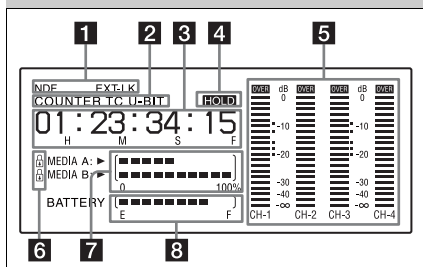

1 Timecode status

NDF: Appears when non-drop-frame timecode is selected.

EXT-LK: Appears when the internal timecode generator is locked to an external signal input to the TC IN (timecode input) connector.

2 Counter display mode

Shows the type of information selected by the DISPLAY switch to be displayed in the time counter display.

COUNTER: Counter values

TC: Timecode

U-BIT: User bits data

3 Time counter display

Switches displays of time counter values, timecode, and user bits data, depending on the position of the DISPLAY switch.

When the HOLD button is pressed to hold the timecode value, the timecode is displayed in the format shown below. When the HOLD button is pressed again to release the hold, the timecode is displayed in the normal format.

Auto Focus Lens (Supplied with the PMW-350K)

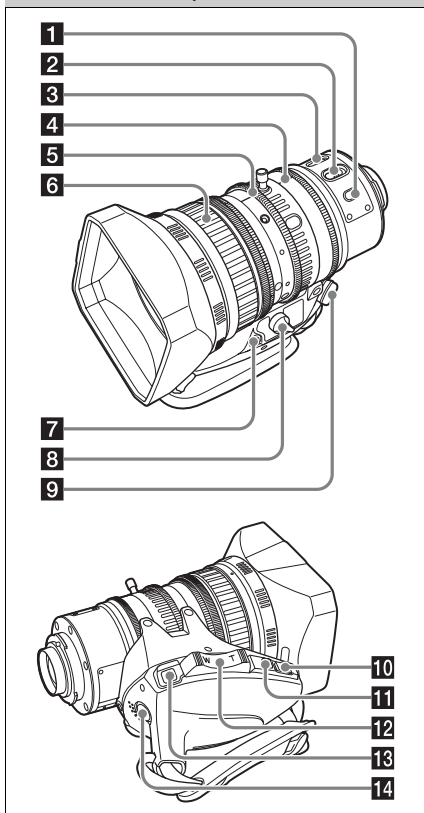

1 PUSH AF (auto focus) button

When the focus adjustment is in the manual mode, by pressing this button you can use the auto focus for an instantaneous adjustment to the subject.

When the button is pressed, the auto focus operates until the image is in focus, then disengages.

Even when the FOCUS switch is set to A (auto), by pressing this button, you can restart the auto focus.

2 FOCUS switch

A (auto): The auto focus function is constantly active. Even with the switch in the A position, you can manually adjust the focus by operating the focus ring.

M (manual): The manual mode allows focusing adjustment with the focus ring.

In manual mode, auto focus adjustment is also possible, by pressing the PUSH AF button.

3 MACRO switch

When this switch is in the ON position, the macro mode is enabled, allowing focusing over the whole range (5 cm¹⁾ to ∞) including the macro range (from 5 cm¹⁾ to 90 cm from the front of the lens).

This operation is independent of whether the focus adjustment mode is auto or manual.

In the macro range, the auto focusing speed is lower.

1) At the wide-angle setting

4 Iris ring

For manual iris adjustment, set the IRIS switch to the M (manual) position, then turn this ring.

5 Zoom ring

For manual zoom adjustment, set the ZOOM switch to the MANUAL position, then turn this ring.

6 Focus ring

Turn this ring to adjust the focus.

This ring can be turned endlessly in both directions. The faster you turn, the faster the focusing mechanism operates, to minimize the amount of turning required for focusing.

When you slide the focus ring back (toward the camcorder), the focus mode becomes Full MF mode (see page 59).

7 Flange focal length adjustment button

Press this to adjust the flange focal length (the distance from the lens mounting flange plane to the focusing plane) (see page 42).

8 Zoom control connector (8-pin)

Connecting an optional zoom servo controller allows remote control of zooming.

9 ZOOM switch

SERVO: Motorized zoom. Operate the zoom with the power zoom lever.

MANU. (manual): Manual zoom. Operate the zoom with the zoom ring.

10 PUSH AUTO button

When the IRIS switch is in the M position for manual adjustment, press this button for an instantaneous auto adjustment.

The iris is automatically adjusted while the button is held down.

11 IRIS switch

A (auto): The iris is adjusted automatically.

M (manual): Adjust the iris with the iris ring.

12 Power zoom lever

This is enabled when the ZOOM switch is in the SERVO position. Press the W end for wide-angle and the T end for telephoto.

Press the lever harder for a faster zoom action.

Notes on auto focus

- In the following cases, it may be difficult to focus on the subject. If this does happen, use manual focusing.
 - If the subject has no contrast
 - If the subject is moving rapidly
 - When shooting point light sources, under street lighting or at night
 - When there are very bright objects close to the subject
 - When shooting through a glass window
- If there are a number of objects within the screen at close and far range, the focus may not be on the intended subject. In this case, with the subject on which you want to focus in the center of the screen, press the PUSH AF button.
- After focusing with the PUSH AF button, if you operate the zoom or adjust the iris, the depth of field may become shallower, losing crisp focus. In such cases, press the PUSH AF button once more.
- If you focus at wide-angle then zoom to telephoto, the subject may no longer be in focus.
- It may take time until the image is in focus while using the slow shutter mode.

Note on zoom speed

Depending on the shooting distance, the zoom speed may fall as the lens approaches the telephoto end.

13 RET (return video) button

You can use this as an assignable switch (*see page 134*).

Use this to check the video when Lens RET is assigned to this button (factory default setting). If you press this during recording pause, the last few

seconds recorded appear on the viewfinder screen (recording review) (*see page 72*).

Pressing this button (single click) during recording or playback records a Shot Mark 1 mark, and double-clicking records a Shot Mark 2 mark (*see page 73*).

14 VTR button

Use this to start and stop recording. Press once to start recording, then press once more to stop.

Viewfinder

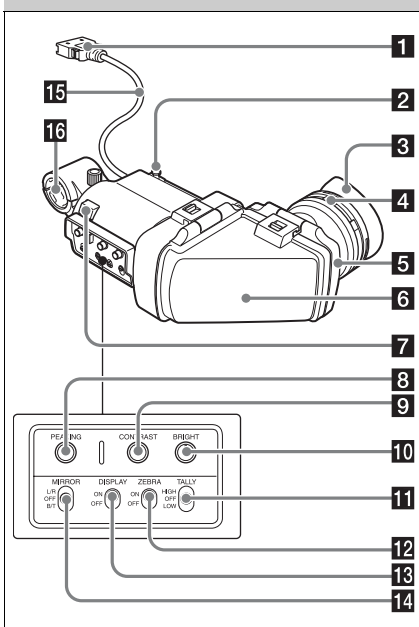

1 Plug

Connect to the VF connector (rectangular) on the camcorder.

2 Stopper

Prevents the viewfinder from coming off the camcorder when it is slid from side to side.

3 Eyecup

4 Diopter adjustment ring

Allows for optimal focus adjustment.

5 Eyepiece

You can raise this up when required by the situation.

6 Viewfinder barrel

You can raise this up or rotate when required by the situation.

7 Tally indicator

Lights up when recording is started by a press of the REC START button on this camcorder, the VTR button on the lens, or the VTR button on the remote control unit.

When an abnormality occurs, the tally indicator flashes to indicate a warning.

8 PEAKING control

Turning this control clockwise adjusts the picture sharpness, and makes focusing easier. This control has no effect on the output signals of the camcorder.

9 CONTRAST control

Adjusts the contrast of the screen. This control has no effect on the output signals of the camcorder.

10 BRIGHT control

Adjusts the brightness of the screen. This control has no effect on the output signals of the camcorder.

11 TALLY switch

Controls the tally indicator located on the front of the viewfinder.

HIGH: The tally indicator brightness is set to high.

OFF: The tally indicator is disabled.

LOW: The tally indicator brightness is set to low.

12 ZEBRA (zebra pattern) switch

Controls the zebra pattern display on the viewfinder screen as follows.

ON: Display a zebra pattern.

OFF: Do not display a zebra pattern.

13 DISPLAY switch

Turns the display of text information on and off.

ON: Display text information.

OFF: Do not display text information.

14 MIRROR switch

The image display on the monitor screen becomes reversed horizontally or vertically when the viewfinder barrel is raised up or rotated. Use this switch to control the image display in such situation.

L/R: Reverse the image horizontally.

OFF: Do not reverse the image.

B/T: Reverse the image vertically.

15 Viewfinder cable**16 Microphone holder**

Viewfinder Screen Display

The viewfinder screen displays not only the video picture but also characters and messages indicating the camcorder settings and operating status, a center marker, a safety zone marker, etc. When the menu screen is not displayed and the DISPLAY switch is set to ON, the items for which an ON setting was made with OPERATION > Super Impose in the setup menu or with related switches are displayed at the top and bottom of the screen.

Caution messages are indicated for three seconds when you carry out operations to change camcorder settings. Adjustment execution messages are indicated while adjustments proceed. When adjustments are finished, messages showing the results of adjustments appear for three seconds.

Not only these indications are displayed on the viewfinder screen, but a menu setting enables them to be output as video signals. All items that can be displayed on the viewfinder screen are shown below.

Top of viewfinder screen

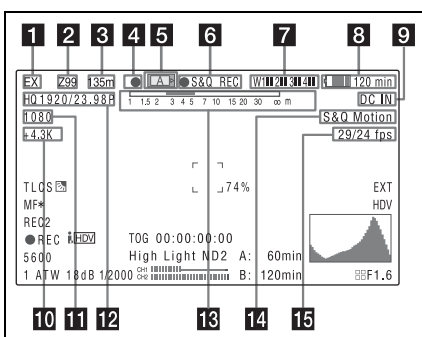

1 Extender settings

Indicates the setting of the digital extender function (by digital extender option) of this camcorder and the setting of the lens extender.

EX: The lens extender is on.

08: The lens shrinker is on.

x2D: The optional digital extender function of this camcorder is on.

Ex2D: The lens extender and the optional digital extender function of this camcorder are both on.

2 Zoom position (when the lens is mounted)

Indicates the zoom position of the zoom lens in the range from 0 to 99.

3 Focus position (when the serial lens is mounted)

Indicates the focus position as distance to the subject (in units of m or f).

4 Green tally

Lights when the camcorder is in the following states.

- MAINTENANCE > Camera Config > HD-SDI Remote I/F is set to [G-Tally] in the setup menu and a recording control signal is output from the HD/SD SDI OUT connector.
- When the Picture Cache mode is enabled

5 Media status

Displays the name of the currently active media slot (A or B).

6 Recording mode/operation status

Indicates the current recording mode/operation status as follows.

Indication	Meaning
●REC	Recording in progress
STBY	Standby for recording
●CACHE	Standby in Picture Cache mode
●INT REC	Recording in progress in Interval Recording mode
●INT STBY	Standby for next recording in Interval Recording mode
INT STBY	Standby in Interval Recording mode
●FRM REC	Recording in progress in Frame Recording mode
●FRM	Standby for next recording in Frame Recording mode
FRM STBY	Standby in Frame Recording mode
●S&Q REC	Recording in progress in Slow & Quick Motion mode
S&Q STBY	Standby in Slow & Quick Motion mode
●CALL	Being called from a connected device
▶REVIEW	During recording review

7 Wireless receiver reception level

When a wireless receiver is installed in the camcorder, “W” appears together with four segment reception level indicators for each of the channels (1 to 4) that can be used by the receiver. The indications are as follows.

In normal situation: The number of white segments indicates the strength of the signal level.

Muting (for an analog receiver) or error rate aggravation (for a digital receiver): The number of gray segments indicates the strength of the signal level.

8 Battery remaining/voltage capacity

The following is displayed depending on the type of power source.

Type of power source	What is displayed
InfoLithium battery	Remaining battery capacity icon and remaining recording time
Anton Bauer battery	Remaining battery capacity (% indication)
Other type than above	Input voltage

9 External power input

Appears when power is supplied from an external power source connected to the DC IN connector.

10 Color temperature

Displays a color temperature calculated from the gain of R and B, in the range 1.5 K to 50.0 K (in steps of 0.1 K). The +/- signs may be displayed depending on the Offset White setting (*see page 92*).

No display: Offset White is OFF

+: The value of Offset White is greater than 3200K.

-: The value of Offset White is less than 3200K.

11 Number of system lines

Indicates the number of system lines (1080/720/576/480) of video currently being recorded or played back.

12 Video format

Indicates the format of video being currently played back or recorded (*see page 50*). The video aspect ratio (16:9 or 4:3) can also be displayed when the recording format is set to DVCAM.

13 Depth of field indication (when the serial lens is mounted) Error/warning indication

A bar indicates the depth of field. An error or warning message is displayed here depending on the situation.

14 Special recording mode indication

The following is displayed when the camcorder is in a special recording mode.

- Frame Rec (Frame Recording mode)
- Interval Rec (Interval Recording mode)
- S&Q Motion (Slow & Quick Motion mode)

15 Special recording mode settings indication

Appears when the camcorder is in a special recording mode.

Bottom of viewfinder screen

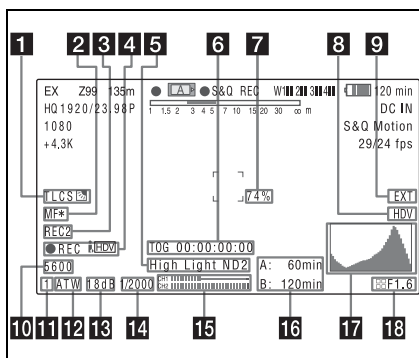

1 TLCS iris control mode

The following icons are displayed to indicate the video level control modes based on the Total Level Control System (TLCS).

Icon	TLCS control mode
	Backlight mode
	Standard mode
	Spotlight mode

2 Focus adjustment mode (when the auto focus lens is mounted)

Indicates the current focus adjustment mode of the camcorder.

- AF (Auto Focus mode)
- MF (Manual Focus mode)





- MF* (Manual Focus mode when the MF Assist function is on)
- Full MF (Full Manual Focus mode)

3 External device control

“REC2” is displayed when MAINTENANCE >Camera Config >HD-SDI Remote I/F is set to [Chara] in the setup menu and a recording control signal is output from the HD/SD SDI OUT connector.

4 Operation status of connected i.LINK device

The operating format (HDV or DV) and operation status of that device are indicated as follows.

Indication	Meaning
●REC 	HDV recording in progress
STBY 	Standby for HDV recording
●REC 	DV recording in progress
STBY 	Standby for DV recording

5 Video level indication

An indication is displayed together with an appropriate ND filter position number when the light level of the subject is too high or too low.

6 Timecode

Caution message

Indicates the elapsed recording/playback time, timecode, user bits data or other information selected by the DISPLAY switch (*see page 21*). Also indicates a caution message when caution is required such as when you try to change settings.

7 Brightness level

Indicates the average brightness level (%) of the detection area.

8 External input source

Indicates the type of external input signal (HDV) to be recorded.

9 Recording of external input

Indicates “EXT” when an external input is recorded.

10 Electric color temperature filter

When the electric color temperature filter is set to ON, the set value of color temperature is displayed.

11 ND Filter

Indicates the currently selected ND filter position number. (*see page 16*).

12 White balance memory

Indicates the currently selected white balance automatic adjustment memory.

ATW: ATW (Auto Tracing White Balance) mode

W:A: Memory A mode

W:B: Memory B mode

W:P: Preset mode

13 Gain value

Indicates the gain value (in dB) of the video amplifier, as set by the GAIN selector.

14 Shutter

Indicates the shutter speed or the shutter mode.

For details, see “Setting the Electronic Shutter” (*page 55*).

15 Audio level meters

Indicate the audio levels of channel 1 and channel 2.

16 Remaining media capacity

Indicates the recording time remaining for each of the media loaded in the slots. The available time for recording with the current video format (recording bit rate) is calculated according to the remaining space of each media and indicated in time units of minutes. A lock icon appears if the media is write-protected.



17 Histogram

Shows a pixel distribution of video luminance (HD mode only).

18 Iris position (when the lens is mounted)

Indicates the iris position and the setting for iris override (reference value for the lens iris) (*see page 57*).

The iris override setting is indicated by four segments indicator as follows.

Reference value	Indicator	
+0.25		Lower left segment is lit in grey.
+0.5		Left two segments are lit in grey.
+0.75		Left two segments and lower right segment are lit in grey.

Reference value	Indicator	
+1	■ ■ ■ ■	All segments are lit in grey.
-0.25	□	Lower left segment is lit in white.
-0.5	□ □	Left two segments are lit in white.
-0.75	□ □ □	Left two segments and lower right segment are lit in white.
-1	□ □ □ □	All segments are lit in white.

Preparing a Power Supply

For safety, use only the Sony battery packs and AC adaptors listed below.

- BP-GL95/GL65/L60S/L80S Lithium-ion Battery Pack
- AC power using the AC-DN2B/DN10 AC Adaptor

CAUTION

Danger of explosion if battery is incorrectly replaced. Replace only with the same or equivalent type recommended by the manufacturer.

When you dispose of the battery, you must obey the law in the relative area or country.

ATTENTION

Il y a danger d'explosion s'il y a remplacement incorrect de la batterie. Remplacer uniquement avec une batterie du même type ou d'un type équivalent recommandé par le constructeur.

Lorsque vous mettez la batterie au rebut, vous devez respecter la législation en vigueur dans le pays ou la région où vous vous trouvez.

VORSICHT

Explosionsgefahr bei Verwendung falscher Batterien. Batterien nur durch den vom Hersteller empfohlenen oder einen gleichwertigen Typ ersetzen.

Wenn Sie die Batterie entsorgen, müssen Sie die Gesetze der jeweiligen Region und des jeweiligen Landes befolgen.

Using a Battery Pack

When a BP-GL95/GL65/L60S/L80S Battery Pack is used, the camcorder will operate continuously for the time shown below.

Model name	Operating time
BP-GL95	Approx. 310 minutes
BP-GL65	Approx. 210 minutes
BP-L60S	Approx. 210 minutes
BP-L80S	Approx. 270 minutes

WARNING

Batteries shall not be exposed to excessive heat such as sunshine, fire or the like.

AVERTISSEMENT

N'exposez pas les batteries à une chaleur excessive, au soleil ou près d'un feu par exemple.

WARNUNG

Akkus dürfen keinesfalls übermäßiger Wärmeeinwirkung ausgesetzt werden, wie z.B. Sonneneinstrahlung, Feuer o. ä.

Note

The battery pack operating time depends on the frequency of use of the battery pack, and the ambient temperature when used.

Before use, charge the battery pack with a charger suitable for each battery.

For details on the battery charging procedure, refer to the battery charger operation manual.

Note on using the battery pack

A warm battery pack may not be able to be fully recharged.

To attach the battery pack

- 1 Press the battery pack against the back of the camcorder, aligning the line on the side of the battery pack with the matching line on the camcorder.**

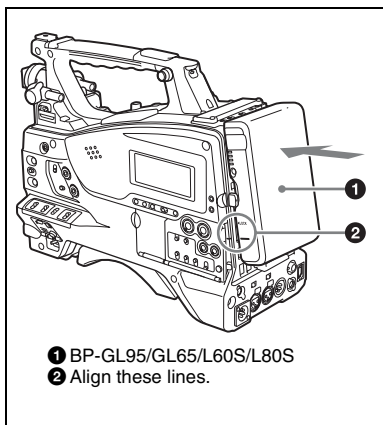

- 2 Slide the battery pack down until its “LOCK” arrow points at the matching line on the camcorder.

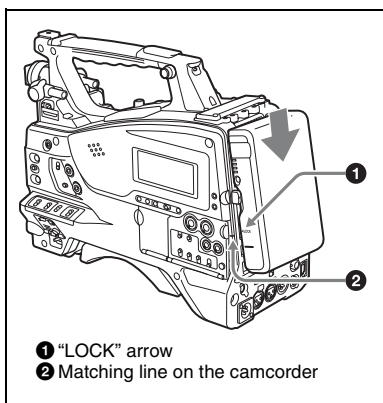

Note

If the battery pack is not attached correctly, the terminal may be damaged.

To detach the battery pack

Holding the release button in, pull the battery pack up.

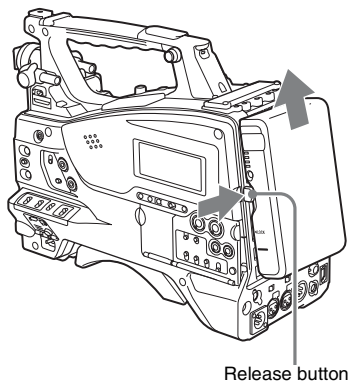

Notes

- During recording and playback (while the ACCESS indicator is lit), be careful never to remove the battery pack.
- Make sure to power the camcorder off before replacing the battery pack.

Using AC Power

Mount an AC-DN2B/DN10 on the camcorder in the same way as a battery pack, then connect to the AC power supply.

The AC-DN2B/DN10 can supply up to 100 W of power.

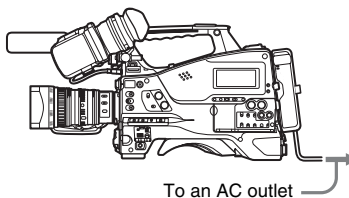

Attaching the Viewfinder

CAUTION

When the viewfinder is attached, do not leave the camcorder with the eyepiece facing the sun. Direct sunlight can enter through the eyepiece, be focused in the viewfinder and cause fire.

Attaching the Supplied Viewfinder

Note

When attaching the viewfinder, make notes of the following points.

- Be sure to power off the camcorder before coupling the viewfinder connector to the camcorder's VF connector (rectangular). If you make this connection when the camcorder power is on, the viewfinder may not function properly.
- Couple the viewfinder connector firmly to the camcorder's VF connector (rectangular). If the coupling is loose, noise may appear on the video or the tally indicator may not operate properly.

- 1 **Loosen the viewfinder left-to-right positioning ring, 2 attach the viewfinder to the viewfinder fitting shoe, and 3 tighten the viewfinder left-to-right positioning ring.**

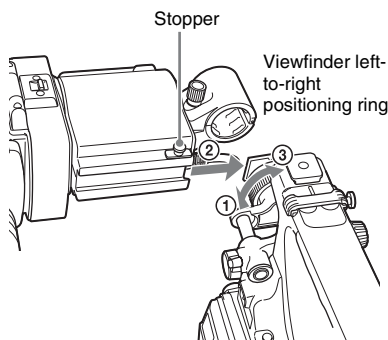

- 2 **Couple the viewfinder connector to the VF connector (rectangular).**

VF connector (rectangular)

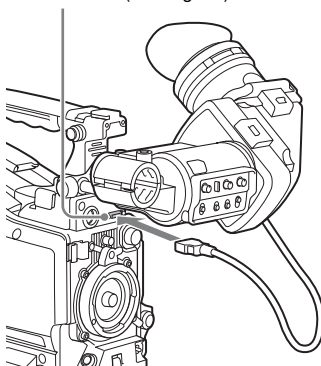

Detaching the viewfinder

You can detach the viewfinder by following the attaching procedure in reverse order, but there is an additional action to take: when detaching the viewfinder from the fitting shoe, pull up the stopper.

Adjusting the Viewfinder Position

To adjust the viewfinder left-to-right position, loosen the left-to-right positioning ring, and to adjust the front-to-back position, loosen the front-to-back positioning knob.

Viewfinder left-to-right positioning ring

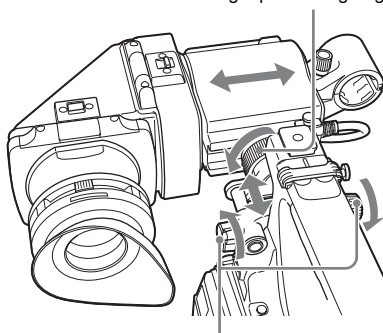

Viewfinder front-to-back positioning knob

Adjusting the Viewfinder Angle

You can adjust the angle of the viewfinder.

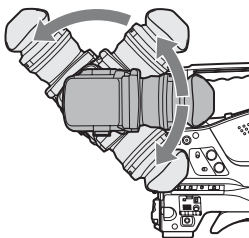

To reverse the display (image/text indication) vertically

The viewfinder can be rotated as much as 180 degrees toward the direction facing the subject. When you do this, the picture and other information displayed in the viewfinder appear upside down. To restore the normal display, set the MIRROR switch on the rear panel of the viewfinder to B/T.

Lifting Up the Viewfinder Barrel and Eyepiece

You can view the LCD screen inside the viewfinder or its mirrored image by lifting up the viewfinder barrel or the eyepiece. This section describes how to lift up the viewfinder barrel and detach it. The eyepiece can also be lifted up and detached in the same way.

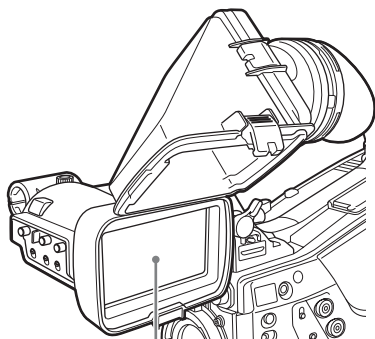

LCD screen

To raise up the viewfinder barrel

Push the clip on the bottom to release and flip up the viewfinder barrel.

It locks at the 120-degree position.

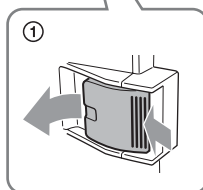
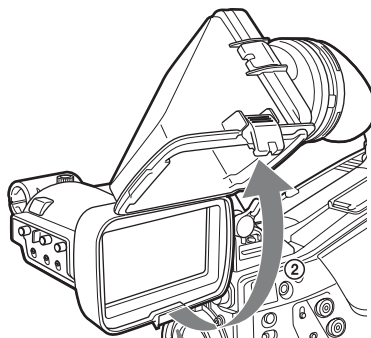

Normally use it in the locked position.

Although you can open it farther from the lock position, once return it to the closed position to lock it at the 120-degree position again.

To detach the viewfinder barrel

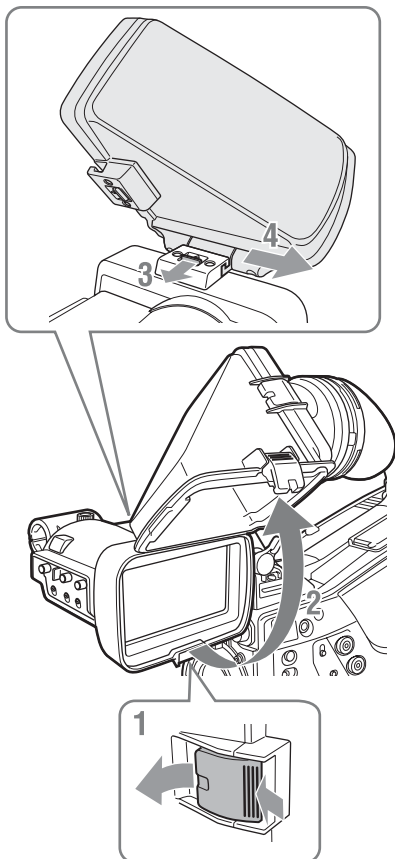

- 1** Push the clip on the bottom to release.
- 2** Flip up the viewfinder barrel.
- 3** Slide the knob on the top to the opposite side of the viewfinder barrel.
- 4** Detach the viewfinder barrel by horizontally sliding it.

To reverse the display (image/text indication) horizontally

By setting the MIRROR switch on the rear panel of the viewfinder to L/R, you can reverse the picture and other information displayed in the viewfinder horizontally.

Adjusting the Viewfinder Focus and Screen

To adjust the viewfinder focus

Turn the diopter adjustment ring until the viewfinder image is sharpest.

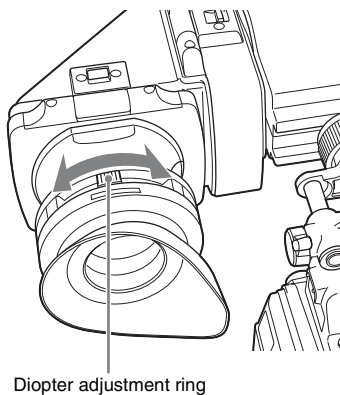

To adjust the viewfinder screen

Adjust the brightness, contrast, and peaking of the viewfinder screen with the controls shown below.

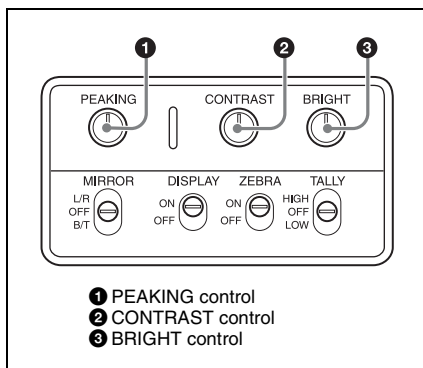

Using the BKW-401 Viewfinder Rotation Bracket

By fitting an optional BKW-401 Viewfinder Rotation Bracket, you can rotate the viewfinder out of the way so that your right leg does not hit the viewfinder while you are carrying the camcorder.

- 1 Loosen the front-to-back viewfinder positioning levers and the front-to-back viewfinder positioning knobs, and then pull the viewfinder slide assembly forward.

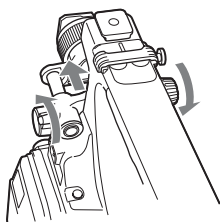

- 2 Using a 2.5 mm diameter hexagonal wrench, detach the viewfinder slide assembly.

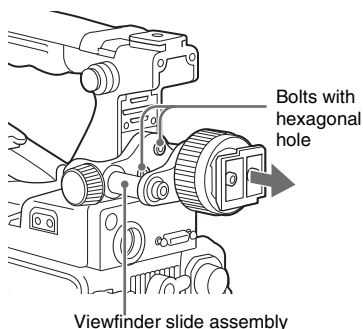

- 3 Attach the BKW-401 with the supplied bolts.

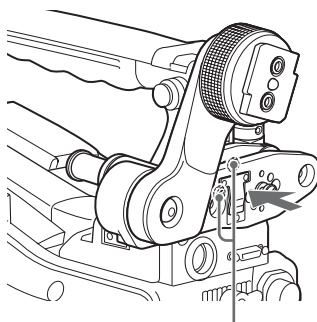

Bolts supplied with the BKW-401

- 4 Adjust the front-to-back position so that the arm of the BKW-401 does not touch the handle when it is raised.

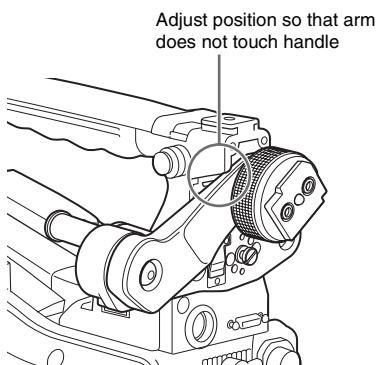

Attaching a 5-inch Electronic Viewfinder

You can attach an optional DXF-51 (5-inch) Electronic Viewfinder. To attach it, an Accessory Shoe Kit (service part number: A-8274-968-B) is required.

For details, consult a Sony service representative.

Note

It is not possible to use the supplied viewfinder and a 5-inch viewfinder at the same time.

Remove the cover of the grip, and attach the shoe and stopper screw of the Accessory Shoe Kit.

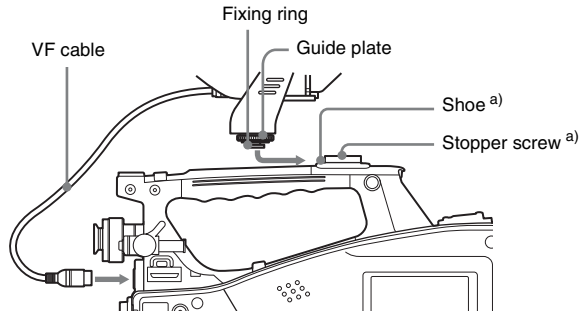

a) Supplied with the Accessory Shoe Kit

Setting the Area of Use

When using the camcorder for the first time

The area of use is not factory preset. Before using the camcorder, you need to set this item. (You cannot use the camcorder without setting this item.)

To set the area of use

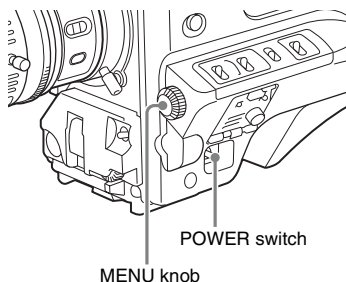

1 Set the **POWER switch** to the **ON** position.

The screen for setting the area of use appears in the viewfinder.



2 Press the **MENU knob**.

The settings for selectable areas of use are displayed.

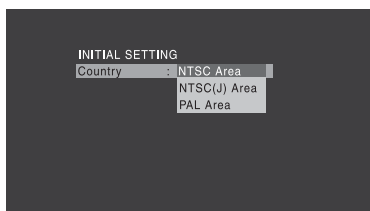

3 Turn the **MENU knob** to select the desired area of use.

Setting	Area of use
NTSC Area	NTSC area (for areas other than Japan) ^{a)}
NTSC(J) Area	NTSC area (Japan) ^{b)}
PAL Area	PAL area ^{c)}

- a) The composite signal output from this camcorder is an NTSC signal with a black setup (7.5 IRE). The system frequency is 59.94i.
- b) The composite signal output from this camcorder is an NTSC signal with no black setup. The system frequency is 59.94i.
- c) The composite signal output from this camcorder is a PAL signal. The system frequency is 50i.

4 Set the following items.

- Time Zone
- Date/Time

See “Basic Setup Menu Operations” (page 94).

5 Turn the **MENU knob** to select “Finish”, then press the **MENU knob**.

The camcorder is now ready for use.

Setting the Date/Time of the Internal Clock

You can set or change the date and time of the internal clock. The date and time set are reflected in the timecode.

For menu operations, see “Basic Setup Menu Operations” (page 94).

- 1 Select **MAINTENANCE >Clock Set >Date/Time** in the setup menu.

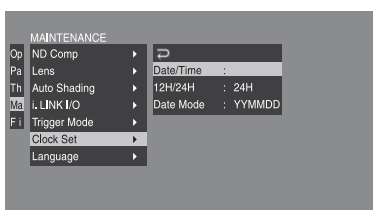

- 2 Press the **MENU knob**. The Date/Time setting window appears.

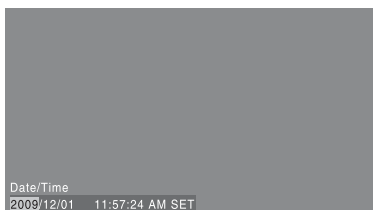

- 3 Turn the **MENU knob** to display the desired value, and press the knob. The selection shifts to the next item on the right.
- 4 To continue the remaining settings, repeat step 3.
- 5 Making sure that “SET” is selected, press the **MENU knob**. The internal clock is set with the date and time set in steps 3 and 4.

To cancel the setting

Before executing step 5, push the **MENU CANCEL/PRST/ESCAPE** switch up to the CANCEL/PRST side.

Mounting and Adjusting the Lens

First power off the camcorder, and then mount the lens using the following procedure.

For information about using the lens, refer to the operation manual for the lens.

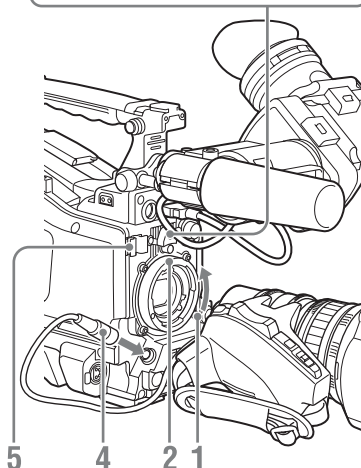
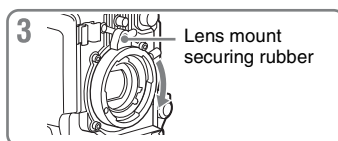

- 1 Push the lens locking lever up and remove the lens mount cap from the lens mount.
- 2 Align the center pin on the lens with the center slot in the lens mount, and insert the lens into the mount.
- 3 Holding the lens in place, push the lens locking lever down to lock the lens.

Caution

If the lens is not firmly locked, it may come off while the camcorder is being used. This could cause a serious accident. Make sure the lens is firmly locked. It is recommended that the lens mount securing rubber be put on the lens locking lever as illustrated above.

- 4 Connect the lens cable to the LENS connector.**
- 5 Secure the lens cable with the cable clamps.**

If you have attached an aberration correction lens

The aberration correction function is activated automatically. Starting the camcorder with an aberration correction lens may require more time than normally because of data loading at start-up. The lens supplied with the PMW-350K is an aberration correction lens. Contact a Sony service representative for information about other aberration correction lenses.

Adjusting the Flange Focal Length

If the lens does not stay in focus properly as you zoom from telephoto to wide angle, adjust the flange focal length (the distance from the plane of the lens mounting flange to the imaging plane). Make this adjustment just one time after mounting or changing the lens.

When carrying out the adjustment, use the supplied flange focal length adjustment chart as the subject.

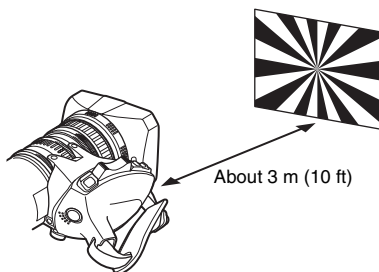
**Note**

If you use a subject with insufficient contrast, or move the camcorder or subject during adjustment, this will cause an adjustment error.

Carrying out the adjustment**When using the auto focus lens**

With the lens supplied with the PMW-350K, zoom and focus operations automatically adjust the flange focal length.

- 1 Open the iris, position the supplied flange focal length adjustment chart approximately 3 meters (10 ft) away from the camcorder, and arrange the lighting to obtain a satisfactory video output.**
- 2 Set the ZOOM switch to SERVO (power zoom mode).**
- 3 Hold down the flange focal length adjustment button for 3 seconds.**

The flange focal length adjustment starts.

During adjustment

The message "AUTO FB EXECUTING" appears on the viewfinder screen.

If the adjustment completes correctly

The message on the viewfinder screen changes to "FB: OK".

If the flange focal length adjustment does not complete correctly

Check the subject and lighting conditions, and repeat the adjustment.

When using a non-auto focus lens

- 1 Set the iris to manual.**
- 2 Open the iris, position the supplied flange focal length adjustment chart approximately 3 meters (10 ft) away from the camcorder, and arrange the lighting to obtain a satisfactory video output.**
- 3 Loosen the fixing screws on the F.f or F.B ring (flange focal length adjustment ring).**
- 4 Use manual or power zoom to set the lens to telephoto.**
- 5 Point the camcorder at the chart by turning the focus ring and focus on it.**

- 6 Set the zoom ring to wide angle.
- 7 Turn the F.f or F.B ring until the chart is in focus, being careful not to disturb the focus ring.
- 8 Repeat steps 4 to 7 until the chart stays in focus all the way from wide angle to telephoto.
- 9 Tighten the F.f or F.B ring fixing screws.

Preparing the Audio Input System

Connecting a Microphone to the MIC IN Connector

Attach the supplied microphone to the microphone holder of the supplied viewfinder.

- 1 Loosen the screw and open the microphone holder clamp.

Microphone holder clamp

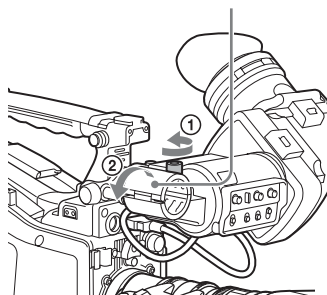

- 2 Place the microphone in the microphone holder.
 - ① Wind the microphone spacer around the microphone, while peeling off the protective sheets on both sides of the microphone spacer.
 - ② Place the microphone in the holder so that "UP" is at the top.
 - ③ Close the microphone holder.
 - ④ Tighten the screw.

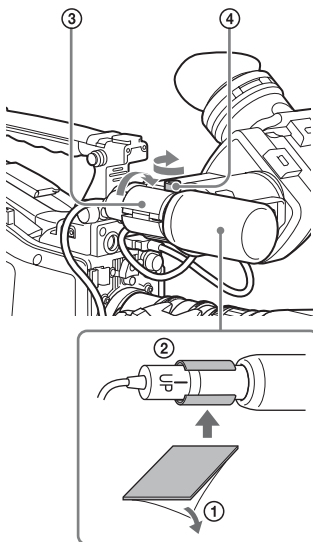

On how to perform this operation, refer to the operation manual for the microphone.

- 3 Plug the microphone cable into the MIC IN connector, then set the AUDIO IN switch for the channel on which you want to record the audio from this microphone to FRONT (for CH-1/CH-2 switch) or F (for CH-3/CH-4 switch).**

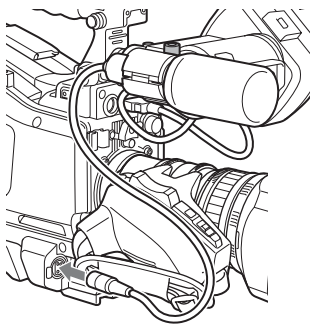

- 4 Secure the microphone cable with the cable clamp.**

Connecting Microphones to the AUDIO IN Connectors

You can connect up to two monaural microphones to the AUDIO IN CH1/CH2 connectors, using an optional CAC-12 Microphone Holder.

The following is the procedure for attaching an electret condenser microphone such as the ECM-674/678.

On how to attach the CAC-12, refer to the operation manual for the CAC-12.

1 Attach the electret condenser microphone.

- ① Loosen the ball joint lock lever.
- ② Wind the microphone spacer (sheet type, supplied with the microphone) around the protective sheets on both sides of the microphone spacer.
- ③ Place the microphone in the holder so that “UP” is at the top.
- ④ Close the microphone holder.
- ⑤ Tighten the screw.
- ⑥ Position so that the microphone does not interfere with the viewfinder and tighten the ball joint lock lever.

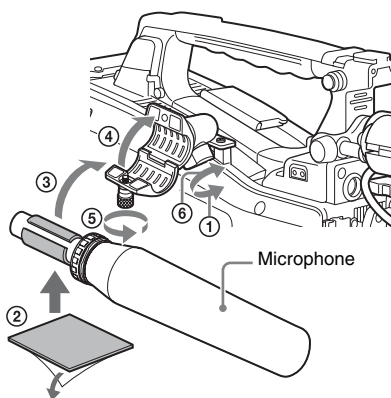

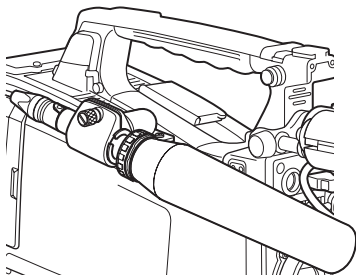

2 Connect the microphone cable to the AUDIO IN CH1 or CH2 connector.

3 Set the switches as follows.

- Set the AUDIO IN selectors indicated below, depending on the power supply type of the microphone.

Internal power supply: MIC

External power supply: +48V

- Set the AUDIO IN CH-1/CH-2 switch for the channel to which the microphone is connected to REAR.

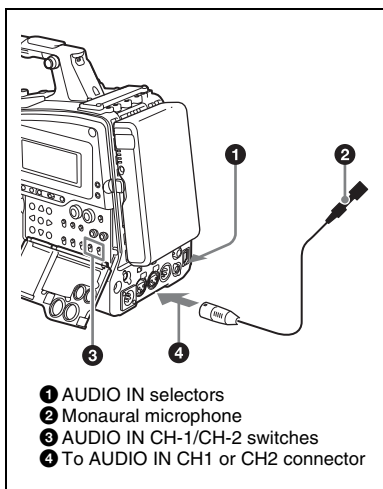

- 1 AUDIO IN selectors
- 2 Monaural microphone
- 3 AUDIO IN CH-1/CH-2 switches
- 4 To AUDIO IN CH1 or CH2 connector

4 Switch the input level to match the sensitivity of the microphone used.

Switch the input level by changing the setting of MAINTENANCE > Audio > Rear MIC CH1/CH2 Ref in the setup menu (factory default setting is -60 dB). *For details, see page 117.*

Notes

- If the input level on the camcorder is not at an appropriate setting for the microphone sensitivity, loud sounds may be distorted, and the signal-to-noise ratio may be affected.
- In order for the AUDIO IN CH1 and CH2 connectors on the camcorder to be able to provide a phantom 48 V power supply, female XLR connectors (3-pin) are fitted. If the microphone cable has a female connector, use an adaptor.
- When you detach a CAC-12 Microphone Holder once you have attached to the camcorder, be careful not to lose the two screws fixing the CAC-12 (in step 1). After detaching the CAC-12, be sure to put the two screws back into their original places.

Attaching a UHF Portable Tuner (for a UHF Wireless Microphone System)

To use a Sony UHF wireless microphone system, power the camcorder off and then fit one of the following UHF portable tuners.

- DWR-S01D Digital Wireless Receiver
- WRR-855S UHF Synthesized Tuner Unit
- WRR-860A/861/862 UHF Synthesized Diversity Tuner

For details of these units, refer to the operation manuals for them.

To fit the DWR-S01D or WRR-855S

- Remove the four fixing screws holding the cover of the portable tuner/receiver housing slot located in the rear of the camcorder, to remove the cover.

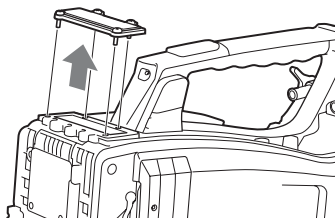

- Insert the DWR-S01D or WRR-855S into the housing slot, and fasten the four fixing screws.

DWR-S01D or WRR-855S

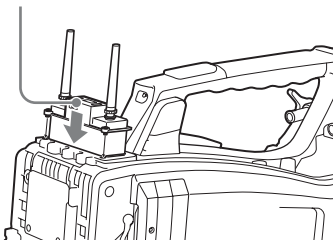

- 3** Set the **AUDIO IN** selector for the channel to which you want to input audio signal to **WIRELESS** (see page 22).

Tripod Mounting

- 1** Attach the optional **VCT-14/U14 Tripod Adaptor** to the tripod.

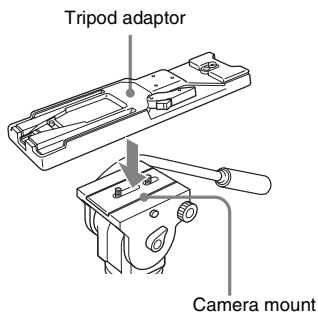

- 2** Mount the camcorder on the tripod adaptor.

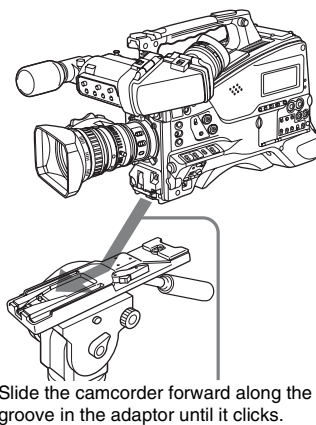

To remove the camcorder from the tripod adaptor

Hold down the red button and pull the lever in the direction of the arrow.

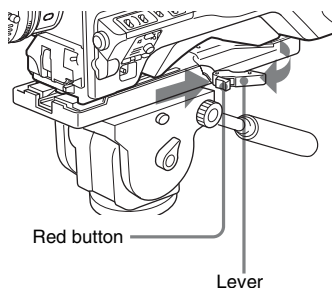
**Note**

The tripod adaptor pin may remain in the engaged position even after the camcorder is removed. If this happens, press the red button and move the lever as shown above until the pin returns to the stowed position. If the pin remains in the engaged position, you will not be able to mount the camcorder on the tripod adaptor.

Connecting a Video Light

With this camcorder, you can use the Anton Bauer Ultralight 2 or equivalent video light (powered by 12 V with maximum power consumption of 50 W).

- If you connect the video light to the LIGHT connector on the camcorder and set the LIGHT switch to AUTO, you can turn the light on and off automatically as you start and stop recording on this camcorder.
- The output of the LIGHT connector on the camcorder is controlled to 12 V even when the camcorder is supplied with over 12 V power (through the DC IN connector or battery pack). The brightness or color temperature of the light will not change according to voltage increase.

Notes

- Do not use a video light with power consumption of over 50 W.
- The brightness or color temperature of the light will change when the voltage (supplied through the DC IN connector or from the battery pack) is under 12 V.

To attach the video light

Fit the video light to the accessory fitting shoe on the camcorder grip, and connect the video light cable to the LIGHT connector.

Note

The accessory fitting shoe on the camcorder is of the $\frac{1}{4}$ -inch tapped hole type. If you want to replace this with a slide-type shoe, contact a Sony service representative.

Using the Shoulder Strap

To attach the shoulder strap

- 1 Fit one of the clips to a shoulder strap fitting.

Pull up the strap to lock the fitting.

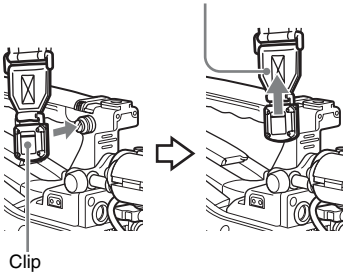

- 2 Fit the other clip to the shoulder strap fitting on the other side of the grip in the same way as in step 1.

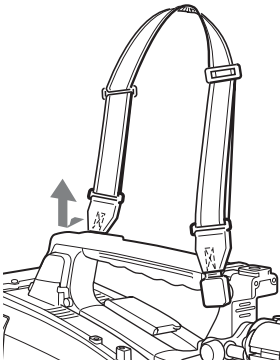

To remove the shoulder strap

Press here and pull in the direction shown by the arrow to release.

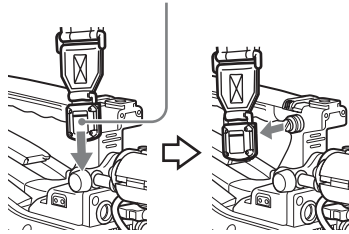

Adjusting the Shoulder Pad Position

You can slide the shoulder pad back and forth within a 40 mm range. This adjustment helps you get the best balance for shooting with the camcorder on your shoulder.

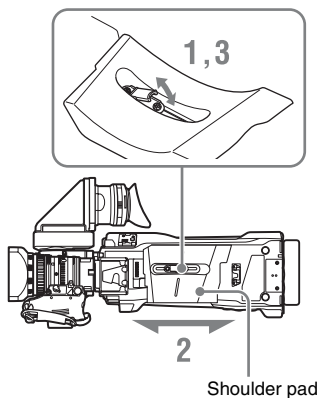

- 1** Raise the lever in the center of the shoulder pad to unlock the shoulder pad.
- 2** Slide the shoulder pad backward or forward until it is in the most convenient position.
- 3** Bring down the lever to lock the shoulder pad in the selected position.

For menu operations, see “Basic Setup Menu Operations” (page 94).

Setting the Video Format

The following recording formats can be selected for different combinations of video resolution and system frequency.

OPERATION >Format menu settings				Video format (recording	Frame size	
HD/SD	System Line	Rec Format	System Frequency ^{a)}	format/system frequency)		
HD	1080	HQ 1920	59.94i	HQ 1920/59.94i	1920×1080	
			50i	HQ 1920/50i		
			29.97P	HQ 1920/29.97P		
			25P	HQ 1920/25P		
			23.98P	HQ 1920/23.98P		
		HQ 1440	59.94i	HQ 1440/59.94i		1440×1080
			50i	HQ 1440/50i		
			29.97P	HQ 1440/29.97P		
			25P	HQ 1440/25P		
			23.98P	HQ 1440/23.98P		
		SP 1440	59.94i	SP 1440/59.94i		
			50i	SP 1440/50i		
			23.98P ^{b)}	SP 1440/23.98P		
720	HQ 1280	59.94P	HQ 1280/59.94P	720×1280		
		50P	HQ 1280/50P			
		29.97P	HQ 1280/29.97P			
		25P	HQ 1280/25P			
		23.98P	HQ 1280/23.98P			
SD	—	DVCAM ^{c)}	59.94i	DVCAM/59.94i	720×480	
			50i	DVCAM/50i	720×576	
			29.97P ^{d)}	DVCAM/29.97P	720×480	
			25P ^{d)}	DVCAM/25P	720×576	

a) **59.94i/29.97P/59.94P/23.98P**: When OPERATION >Format >Country in the setup menu is set to [NTSC Area] or [NTSC(J) Area]

50i/25P/50P: When OPERATION >Format >Country in the setup menu is set to [PAL Area]

b) 59.94i after 2-3 pulldown is recorded

c) When the optional CBK-DV01 is installed

d) Converted to PsF and recorded

Changing the Video Format

Refer to the above table and change the settings of the relevant items.

- 1 Select **OPERATION >Format** in the setup menu (see page 96).

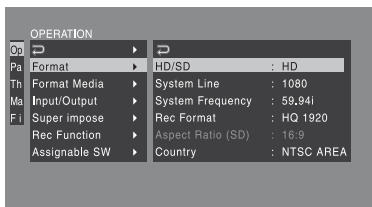

- 2 Turn the **MENU knob** to select the item to change, and press the knob.
- 3 Turn the **MENU knob** to change the setting, and press the knob.
A confirmation message appears.
- 4 Select **[Execute]** to execute, or select **[Cancel]** to cancel, and then press the **MENU knob**.
- 5 When the setting of **HD/SD** or **Country** was changed, power the camcorder off and on again.

Adjusting the Black Balance and the White Balance

To ensure excellent image quality when using this camcorder, conditions may require that both the black balance and the white balance be adjusted. Black balance and white balance adjustment values that are automatically set by the camcorder and the various settings are stored in the camcorder memory and retained even when the power is turned off.

Black balance adjustment

The black balance will require adjustment in the following cases.

- When the camcorder is used for the first time
- When the camcorder has not been used for a long time
- When the camcorder is used under conditions in which the surrounding temperature has changed greatly
- When the GAIN selector (L/M/H/Turbo) values have been changed by using **OPERATION >Gain Switch** in the setup menu.

It is not usually necessary to adjust the black balance when using the camcorder after it has been off.

White balance adjustment

Always readjust the white balance when the lighting conditions change.

Adjusting the Black Balance

In automatic black balance mode, adjustments are performed in the following order: black set and black balance. Manual black balance adjustment can be selected from the setup menu.

For details of manual black balance adjustment, refer to the Maintenance Manual.

Automatic black balance adjustment is disabled in the following case.

- During recording
- In a special recording modes (Picture Cache Rec, Interval Rec, Frame Rec, Slow & Quick)
- When i.LINK output is supplied

- When the shutter mode is SLS

1 Set the OUTPUT/DCC switch to CAM.

2 Push the AUTO W/B BAL switch to BLACK and release the switch.

The message “Executing...” appears during execution, and changes to “Done” when the adjustment finishes. Adjustment values are saved to memory automatically.

Notes

- During the black balance adjustment, the iris is automatically closed.
- During the black balance adjustment, the gain selection circuit is automatically activated so you may see flickering on the viewfinder screen, but this is not a fault.

If automatic black balance adjustment cannot be made

If the black balance adjustment cannot be completed normally, an error message will appear for about three seconds on the viewfinder screen. Possible messages are listed below.

Error message	Meaning
NG: Iris Not Closed	The lens iris did not close; adjustment was impossible.
NG: Timeout	Adjustment could not be completed within the standard number of attempts.
NG: Out of Range	The difference between the reference value and the current value is so great that it exceeds the range. Adjustment was impossible.

If any of the above error messages is displayed, retry the black balance adjustment.

If the error message occurs again, an internal check is necessary.

For information about this internal check, refer to the Maintenance Manual.

Note

If the lens cable is not firmly connected to the LENS connector, it may not be possible to adjust the lens iris. If this happens, the black balance will be incorrect.

Adjusting the White Balance

1 Set the switches and selectors as shown below.

- GAIN switch: L (set to a gain value that is as small as possible)
 - OUTPUT/DCC switch: CAM
 - WHITE BAL switch: A or B ^{a)}
- a) Adjustment values are saved to memory B only when OPEATION >White Setting >White Switch in the setup menu, is set to [MEM].

2 Set the FILTER selector to suit the lighting conditions as follows.

3 Place a white test card under the same lighting conditions as for the subject to be shot and zoom up to it.

Alternatively, any white object such as a cloth or a wall can be used.

The absolute minimum white area is as follows.

Rectangle centered on the screen. The lengths of the sides are 70% of the length and width of the screen.

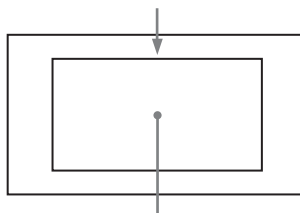

The white object must be within the rectangle and have an area of at least 10% of the screen.

Note

Make sure there are not bright spots in the rectangle.

4 Adjust the lens iris.

Manually adjusted lens: set the iris to an appropriate setting.

Lens with automatic iris: set the automatic/manual switch on the lens to automatic.

5 Push the AUTO W/B BAL switch to WHITE and then release the switch.

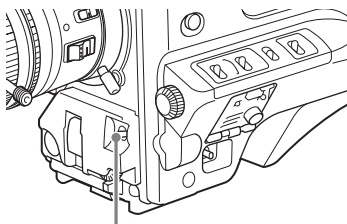

AUTO W/B BAL switch

The message “Executing...” appears during execution, and changes to “OK: (color temperature of subject)” when the adjustment finishes.

The adjustment values are saved automatically in the memory selected in step 1 (A or B).

Note

If the camcorder has a zoom lens with an automatic iris, the iris may hunt ¹⁾ during the adjustment. To prevent this, adjust the iris gain knob (indicated as IG, IS, or S) on the lens.

For details, refer to the lens operation manual.

- 1) **Hunting:** Repeated brightening and darkening of the image, resulting from repeated response to automatic iris control.

If the automatic white balance adjustment cannot be made

If the white balance adjustment cannot be completed normally, an error message will appear for about three seconds on the viewfinder screen. Possible messages are listed below.

Error message	Meaning
NG: Low Light	The white video level is too low. Either open the lens iris or increase the gain.
NG: Timeout	Adjustment could not be completed within the standard number of attempts.
NG: High Light	The white video level is too high. Either stop down the lens iris or change the ND filter.

If any of the above error messages is displayed, retry the white balance adjustment. If the error message occurs again, an internal check is necessary.

For information about this internal check, refer to the Maintenance Manual.

If you have no time to adjust the white balance

Set the WHITE BAL switch to PRST.

This makes it possible to automatically set the white balance to 5600K (factory default value) by pressing the COLOR TEMP. button.

The color temperature to which the white balance is set when the COLOR TEMP. button is pressed can be selected from among 3200K, 4300K, 5600K, and 6300K on OPERATION > Assignable SW in the setup menu. You can also assign color temperatures to the ASSIGN. 1/3 switches or ASSIGNABLE 4/5 switches.

To change the color temperature when the ND filter is switched

You can assign electrical CC (color correction) filters to ND filters (*see page 16*). This allows you to change the color temperature automatically when the ND filter is switched.

- 1 Set MAINTENANCE > White Filter > ND Filter C.Temp in the setup menu (*see page 123*) to On.
- 2 To assign an electrical CC filter to FILTER selector position number 1, select [ND FLT C.Temp<1>]. To assign it to positions 2 to 4, select [ND FLT C.Temp<2-4>].
- 3 Turn the MENU knob to select the desired color temperature. As you turn the MENU knob, the color temperature changes as follows: 3200K ↔ 4300K ↔ 5600K ↔ 6300K.
- 4 Repeat steps 2 and 3 as required.

To switch between electrical CC filters with an assignable switch

You can assign the function that switches between electrical CC filters to an assignable switch. This allows you to switch between color temperatures (3200K/4300K/5600K/6300K) that have been assigned to up to four positions (A to D) with each press of the assignable switch. Regardless of assignments to assignable switches, you can also switch between the color temperatures assigned to each position from a RM-B150/B750 Remote Control Unit.

- 1 Select MAINTENANCE >White Filter in the setup menu (see page 123).**
- 2 Select the position to which to assign a CC filter by selecting one of [Electrical CC<A>] to [Electrical CC <D>], and then turn the MENU knob to select the desired color temperature.**

As you turn the MENU knob, the color temperature changes as follows: 3200K ↔ 4300K ↔ 5600K ↔ 6300K.

To set no color temperature

Select “-----” with Electrical CC<C> or <D> selected.

When the assignable switch is pressed, the setting for that position is not displayed. For example, if “-----” is set for one position, then switching between the remaining three positions is carried out.

- 3 Repeat step 2 as required.**
- 4 Assign the electrical CC filter switching function (ELECTRICAL CC) to an assignable switch (see page 133).**

White balance memory

Values stored in memory are held until the white balance is next adjusted even when the camcorder power is turned off.

The camcorder has two white balance memories, A and B. You can automatically save adjustment values for each ND filter in the memory that corresponds to the WHITE BAL switch setting (A or B). The camcorder has four built-in ND filters, allowing you to save a total of eight adjustment values (4 × 2). However, the contents

of the memories are not linked to ND filter settings in the following cases.

- When the number of memories allocated to each of A and B is limited to one by setting OPERATION >White Setting >Filter White Memory in the setup menu to Off.
- When the electrical CC filter switching function has been assigned to an assignable switch, or when a remote control unit has been connected. (In these cases, the contents of white balance memory are linked to electrical CC filter positions (A to D).)

Also, when OPERATION >White Setting >White Switch in the setup menu is set to [ATW (Auto Tracing White Balance)], and the WHITE BAL switch is set to B, the ATW function is activated to automatically adjust the white balance of the picture being shot for varying lighting conditions.

Setting the Electronic Shutter

Shutter Modes

The shutter modes that can be used with the electronic shutter and the shutter speeds that can be selected are listed below.

Standard mode

Select this mode for shooting fast-moving subjects with little blurring.

You can set the shutter speed in one of two shutter modes: Speed mode, in which the speed is set in seconds, and Angle mode, in which the speed is set in degrees.

Speed mode

System frequency	Shutter speed (unit: seconds)
59.94i	$1/60, 1/100, 1/120, 1/125, 1/250, 1/500$
59.94P	$1/1000, 1/2000$
50i	$1/1000, 1/2000$
50P	
29.97P	$1/40^a, 1/50^a, 1/60, 1/100, 1/120, 1/125, 1/250, 1/500, 1/1000, 1/2000$
25P	$1/33^a, 1/50^a, 1/60, 1/100, 1/120, 1/125, 1/250, 1/500, 1/1000, 1/2000$
23.98P	$1/32^a, 1/48^a, 1/50^a, 1/60, 1/96, 1/100, 1/120, 1/125, 1/250, 1/500, 1/1000, 1/2000$

a) This speed cannot be selected when the camcorder is in Slow & Quick Motion mode and OPERATION >Rec Function >Frame Rate in the setup menu is set to a value that is greater than the system frequency.

Angle mode

180°, 90°, 45°, 22.5°, and 11.25°

ECS (Extended Clear Scan) mode

Select this mode for obtaining images with no horizontal bands of noise when shooting subjects such as monitor screens.

As shown in the following tables, the range of shutter speeds that can be set varies depending on whether the Slow & Quick Motion (S&Q) function is on or off.

System lines: 1080

System frequency	Shutter speed (unit: Hz)	
	S&Q: Off	S&Q: On
59.94i	60.00 to 3800	—
50i	50.00 to 3500	—
29.97P	29.99 to 4100	32.01 to 4100
23.98P	23.99 to 3700	32.02 to 3700
25P	25.00 to 3900	32.03 to 3900

System lines: 720

System frequency	Shutter speed (unit: Hz)	
	S&Q: Off	S&Q: On
59.94P	60.07 to 4100	32.01 to 4100
50P	50.03 to 3900	32.03 to 3900
29.97P	29.99 to 4100	32.01 to 4100
23.98P	23.99 to 3700	32.02 to 3700
25P	25.00 to 3900	32.03 to 3900

SLS (slow speed shutter) mode

Select this mode for shooting subjects in low level lighting conditions.

Number of accumulated frames

2, 3, 4, 5, 6, 7, 8, 16, 32, 64

Notes

- SLS mode cannot be used when the video format is SP 1440/23.98P or when the camcorder is in Slow & Quick Motion mode.
- It is not possible to output the color bar signal, turn the SLS mode on or off, or change the number of accumulated frames when the number of accumulated frames is set to 16, 32 or 64.

Selecting the Shutter Mode and Shutter Speed

Notes

- When the automatic iris is used, the iris opens wider as the shutter speed increases, thus reducing the depth of field.
- The selectable shutter speeds vary depending on the current system frequency.

To switch between Speed mode and Angle mode

- 1 Select **OPEARTION >Shutter Select >Shutter Select** in the setup menu (*see page 108*).
- 2 Turn the **MENU knob** to select **Second or Degree**, and then press the knob.

To set the shutter mode and standard-mode shutter speed

Once the shutter speed is selected, it is retained even when the camcorder power is turned off.

- 1 Push the **SHUTTER selector** from **ON to SELECT**.
The current shutter setting indication appears for about three seconds.
- 2 Before the shutter setting indication disappears, push the **SHUTTER selector** down to **SELECT** again and repeat this until the desired mode or speed appears.

When all modes and speeds are displayed, the display changes in the following order.

Speed Mode (with system frequency 59.94i)



Note

Depending on the frame rate setting (*see page 78*), some shutter speeds cannot be selected in Slow & Quick Motion mode. These speeds are replaced by the slowest selectable shutter speed.

Example: If you perform Slow & Quick Motion shooting when setting the frame rate to 60 and the video format to HQ1280/29.97P

The shutter speed is indicated as follows.

When Slow & Quick Motion mode is off

1/40 → 1/50 → 1/60 → 1/100 → ...

When Slow & Quick Motion mode is on

1/60 → 1/60 → 1/60 → 1/100 → ...

To set the shutter speed in ECS or SLS mode

- 1 Set the shutter mode to **ECS or SLS** (*see the previous item*).
- 2 Turn the **MENU knob** to select the desired frequency or number of frames.

Changing the Reference Value for Automatic Iris Adjustment

The reference value for automatic iris adjustment can be changed to aid the shooting of clear pictures of back-lit subjects, or to prevent blown-out highlights. The reference value for the lens iris can be set within the following range with respect to the standard value.

- 0.25 to 1 (increasing by increments of 0.25):
About 0.25 to 1 stop further open
- -0.25 to -1 (decreasing by increments of 0.25):
About 0.25 to 1 stop further close

Also you can set the area where light detection occurs.

To change the reference value

- 1 Set **OPERATION >Auto Iris >Iris Override in the setup menu to On** (see page 106).
- 2 Set the **MENU ON/OFF switch to OFF**.
- 3 Turn the **MENU knob to change the reference value**.

Note

Be sure to confirm that the current shutter mode is not ECS.

An indicator of the current reference value is shown at the iris position indication (see page 31) on the viewfinder screen.

To make the iris more open

Turn the MENU knob counterclockwise as seen from the front of the camcorder. Select one of 0.25, 0.5, 0.75, or 1.

To stop down the iris

Turn the MENU knob clockwise as seen from the front of the camcorder. Select one of -0.25, -0.5, -0.75, or -1.

The changed reference value is retained until the power of the camcorder is turned off. Even if the reference value is changed, it reverts to the standard value every time the power is turned on.

To set the automatic iris window

- 1 Set **OPERATION >Auto Iris >Iris Window Indication in the setup menu to On**.
The current automatic iris window appears on the viewfinder screen.
If it is not necessary to display the auto iris window on the screen, set to Off.
- 2 Turn the **MENU knob to select Iris Window, and then press the knob**.
- 3 Turn the **MENU knob until the desired auto iris window appears, and then press the knob**.

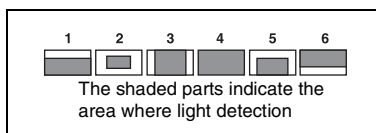

If you select "Var", the following items become effective and you can set the window of the desired size. Set the following items with **MAINTENANCE >Auto Iris2**.

Item	Setting
Iris Var Width	The width of the window
Iris Var Height	The height of the window
Iris Var H Pos	The position of the window in the horizontal direction
Iris Var V Pos	The position of the window in the vertical direction.

When you exit the menu, the auto iris window selected in step 3 appears.

Unless you need to keep this window displayed, set **OPERATION >Auto Iris >Iris Window Indication in the setup menu to Off**.

To counter problems with very bright highlights

If the subject is too bright, the iris may close too much, leaving the overall image dark, or the highlights may be blown out. In such cases, setting the highlight clip function on reduces the luminance range, avoiding problems from the automatic iris correction.

Set **OPERATION >Auto Iris >Clip High Light in the setup menu to On**.

Zooming

The lens supplied with the PMW-350K allows you to shoot with manual and servo zooming.

Switching between Zoom Modes

Set the ZOOM switch to SERVO (servo zoom) or MANU (manual zoom).

Using Manual Zoom

With the ZOOM switch set to MANU, turn the zoom ring.

Using Servo Zoom

With the ZOOM switch set to SERVO, operate the power zoom lever. The current lens zoom position appears in the viewfinder, over the range 0 (wide-angle) to 99 (telephoto) (*see page 29*). Push to the W (wide) side when you want wide-angle, and push to the T (telephoto) side when you want telephoto. The zoom speed increases when you push the lever deeply, and decreases when you push less deeply.

Adjusting the Focus

The lens supplied with the PMW-350K allows you to adjust the focus in the following three ways.

Full MF (full manual focus) mode

This mode supports focusing with the focus ring only.

Without changing your grip, you can focus all the way from ∞ to the shortest shooting distance.

MF (manual focus) mode

In this mode, auto focus is enabled temporarily when you press the PUSH AF button.

You can also use the MF assist function.

AF (auto focus) mode

In this mode, auto focus is always enabled.

The focus ring and the PUSH AF button are also enabled.

Note

The lens is designed with an extra margin at the infinity position (∞), to compensate for focus drifting due to variations in temperature. When shooting a subject at infinity in MF or Full MF mode, check the picture in the viewfinder as you focus.

Adjusting in Full MF Mode

When you slide the focus ring back (toward the camcorder), the focus mode becomes Full MF mode, in which all focus adjustments are manual.

Note

When you slide the focus ring back, the focus instantly moves to the mark position.

Focus by turning the focus ring while viewing the viewfinder.

The distance indications on the ring are valid in Full MF mode. The distances where the picture is in focus correspond to absolute positions of the focus ring.

White line indicating the current distance

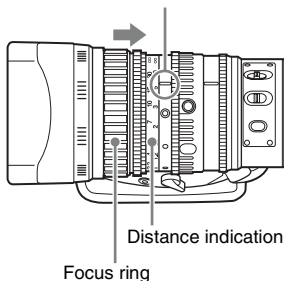

Peaking

You can turn the PEAKING knob on the viewfinder to use the peaking function. Edges are emphasized in the monitor picture, which facilitates manual focusing. The recorded video signals are not affected.

Adjusting in MF Mode

When you slide the focus ring forward (toward the lens hood), and set the FOCUS switch to M (manual), the focus mode becomes MF mode, in which focus adjustments are manual but auto focus is available only when necessary.

Using the focus ring

Focus by turning the focus ring while viewing the viewfinder.

The distance indications on the ring are invalid in MF mode.

One-push auto focus

Press the PUSH AF button. Auto focus is enabled temporarily (one-push auto focus).

One-push auto focus ends when the subject is brought into focus.

MF assist function

When the MF assist function is on, auto focus starts when you stop adjusting with the focus ring, enabling fine adjustments with the subject at the center of the screen.

Auto focusing by the MF assist function ends when the fine adjustments end.

Adjusting in AF Mode

When you slide the focus ring forward, and set the FOCUS switch to A (auto), the focus mode becomes AF mode, in which auto focus is always active.

The distance indications on the ring are invalid in AF mode.

Focusing in AF mode

In AF mode, the camcorder monitors the video for changes, and starts auto focus whenever it detects a change. Auto focusing ends when the subject is in focus, but the auto focus function remains on standby.

In AF mode, you can also start auto focusing by pressing the PUSH AF button or by turning the focus ring.

Using Macro Mode

When the focus mode is MF or AF, you can set the MACRO switch to the ON side to enable macro mode. Macro mode allows you to focus over the range that includes the macro area. Macro mode is disabled in Full MF mode.

Adjusting the Audio Level

When you set the AUDIO SELECT switch to AUTO, the input levels of analog audio signals recorded on each channel are adjusted automatically. You can also make manual adjustments.

Note

Even if you set the AUDIO SELECT switch to AUTO, the input levels of digital audio signals are not adjusted automatically.

Target audio level for manual audio level adjustment

Make adjustment using -20 dB as the target level. If the audio level meter shows a maximum level of 0 dB, then it indicates that the input audio level is excessive.

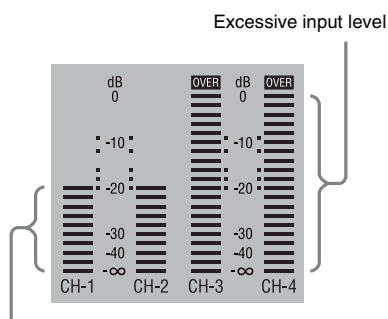

Target input level

Manually Adjusting the Audio Levels of the Audio Inputs from the AUDIO IN CH1/CH2 Connectors

- 1 To adjust the signal input to the AUDIO IN CH1 or CH2 connector, set the AUDIO IN CH-1 or CH-2 switch to REAR.

To adjust both input signals, set both switches to REAR.

- 2 Set the AUDIO SELECT switch(es) corresponding to the channel(s) selected in step 1 to MANUAL.
- 3 With the LEVEL control(s) for the channel(s) selected in step 1, adjust so that the audio level meter shows up to -20 dB for a normal input volume.

Correspondence between recording level adjustments and audio level controls

On MAINTENANCE >Audio in the setup menu, you can select which audio level control controls the audio recording level of the input to each of the AUDIO IN CH1/CH2 connectors. The correspondences between the settings of the menu items and the controls are as follows.

Rear1/WRR Level: Channel 1 recording level

Setting	Knob
Side1	LEVEL (CH1) knob
Front	MIC LEVEL knob
Front+Side1	LEVEL (CH1) knob and MIC LEVEL knob (linked operation)

Rear2/WRR Level: Channel 2 recording level

Setting	Knob
Side2	LEVEL (CH2) knob
Front	MIC LEVEL knob
Front+Side2	LEVEL (CH2) knob and MIC LEVEL knob (linked operation)

Note

When you have operation of the LEVEL (CH-1/CH-2) controls and MIC LEVEL control linked together, if the MIC LEVEL control is set to 0, the audio signals on channels 1 and 2 cannot be recorded. Check the position of the MIC LEVEL control before adjusting the LEVEL (CH-1/CH-2) controls.

Manually Adjusting the Audio Level of the MIC IN Connector

- 1 Set either or both of the AUDIO IN switch(es) to FRONT.
- 2 Set the AUDIO SELECT switch(es) for the desired channel(s) selected in step 1 to MANUAL.

- 3 Turn the MIC LEVEL control, and adjust so that the audio level meter shows up to -20 dB for a normal input volume.**

Correspondence between recording level adjustments and audio level controls

On MAINTENANCE > Audio in the setup menu, you can select which audio level control controls the audio recording level of the front microphone input. The correspondences between the settings of the menu items and the controls are as follows.

MIC CH1 Level: Channel 1 recording level

Setting	Knob
Side1	LEVEL (CH1) knob
Front	MIC LEVEL knob
Front+Side1	LEVEL (CH1) knob and MIC LEVEL knob (linked operation)

MIC CH2 Level: Channel 2 recording level

Setting	Knob
Side2	LEVEL (CH2) knob
Front	MIC LEVEL knob
Front+Side2	LEVEL (CH2) knob and MIC LEVEL knob (linked operation)

Note

When you have operation of the MIC LEVEL control and LEVEL (CH-1/CH-2) controls linked together, if the LEVEL (CH-1/CH-2) controls are set to 0, the audio signals on channels 1 and 2 cannot be recorded. Check the position of the LEVEL (CH-1/CH-2) controls before adjusting the MIC LEVEL control.

Recording Audio on Channels 3 and 4

Selecting the recorded audio

You can select the audio recorded on audio channels 3 and 4 with the AUDIO IN CH3/CH4 switches.

CH3 switch	Channel 3 recording target
FRONT	Front microphone audio
REAR	Audio signal input to AUDIO IN CH1 connector
WIRELESS	Wireless microphone audio

CH4 switch	Channel 4 recording target
FRONT	Front microphone audio
REAR	Audio signal input to AUDIO IN CH2 connector
WIRELESS	Wireless microphone audio

You can have the selection made automatically, as follows.

To automatically select the same audio as on channels 1 and 2

Set MAINTENANCE > Audio > Audio CH3/4 Mode of the setup menu to [CH 1/2].

Adjusting the audio recording levels

To adjust automatically

Set the AUDIO SELECT CH 3-4 switch to AUTO.

To adjust manually

- 1 Set the AUDIO SELECT CH 3-4 switch to MANUAL.
- 2 Select the knobs that adjust the audio levels with the Audio CH3 Level and Audio CH4 Level items under MAINTENANCE > Audio in the setup menu.

Audio CH3 Level: Channel 3 recording level

Setting	Knob
Side3	LEVEL (CH3) knob
Front	MIC LEVEL knob
Front+Side3	LEVEL (CH3) knob and MIC LEVEL knob (linked operation)

Audio CH4 Level: Channel 4 recording level

Setting	Knob
Side4	LEVEL (CH4) knob
Front	MIC LEVEL knob
Front+Side4	LEVEL (CH4) knob and MIC LEVEL knob (linked operation)

You can now adjust the levels of audio channels 3 and 4 with the knobs selected here.

Setting the Time Data

Note

When picture cache mode is enabled, it is not possible to set time data, even if you set the F-RUN/SET/R-RUN switch to SET. If you want to set time data, first exit picture cache mode.

Setting the Timecode

The timecode setting range is from 00 : 00 : 00 : 00 to 23 : 59 : 59 : 29 (hours : minutes : seconds : frames).

- 1 Set the DISPLAY switch to TC.**
- 2 Set the PRESET/REGEN/CLOCK switch to PRESET.**
- 3 Set the F-RUN/SET/R-RUN switch to SET.**
The first (leftmost) digit of timecode flashes.
- 4 Use the up and down arrow buttons to change values, and use the left and right arrow buttons to move the flashing digit. Repeat until all digits are set.**
To reset the timecode value to 00:00:00:00
Press the RESET/RETURN button.
- 5 Set the F-RUN/SET/R-RUN switch to F-RUN or R-RUN.**
F-RUN: Free run. The timecode generator keeps running.
R-RUN: Recording run. The timecode generator runs only while recording.

To set the drop frame mode/non-drop frame mode

You can select the drop frame (DF) mode or non-drop frame (NDF) mode on MAINTENANCE >Timecode in the setup menu.

To make the timecode consecutive

When the F-RUN/SET/R-RUN switch is set to R-RUN, recording a number of scenes on the media normally produces consecutive timecode. However, once you remove the media and record on another media, the timecode will no longer be consecutive when you use the original media again for recording. In this case, to make the timecode consecutive, set the PRESET/REGEN/CLOCK switch to REGEN.

Saving the real Time in the Timecode

Setting the PRESET/REGEN/CLOCK switch to CLOCK saves the real time in the timecode.

When it is necessary to set the actual time, use MAINTENANCE >Clock Set >Date/Time in the setup menu.

For details, see “Setting the Date/Time of the Internal Clock” (page 41).

Setting the User Bits

By setting the user bits (up to 8 hexadecimal digits), you can record user information such as the date, time, or scene number on the timecode track.

- 1 Set the DISPLAY switch to U-BIT.**
- 2 Set the F-RUN/SET/R-RUN switch to SET.**
The first (leftmost) digit flashes.
- 3 Use the up and down arrow buttons to change values, and use the left and right arrow buttons to move the flashing digit. Repeat until all digits are set.**

To reset the user bit data to 00 00 00 00
Press the RESET/RETURN button.
- 4 Set the F-RUN/SET/R-RUN switch to F-RUN or R-RUN, corresponding to the desired operating mode for the timecode generator.**

To store the user bit setting in memory

The user bit setting (apart from the real time) is automatically retained in memory even when the power is turned off.

Synchronizing the Timecode

You can synchronize the internal timecode generator of this camcorder with an external generator for the regeneration of an external timecode. You can also synchronize the timecode generators of other camcorders/VTRs with the internal generator of this camcorder.

Connections for timecode synchronization

Connect both the reference video signal and the external timecode as illustrated below.

Example 1: Synchronizing with an external timecode

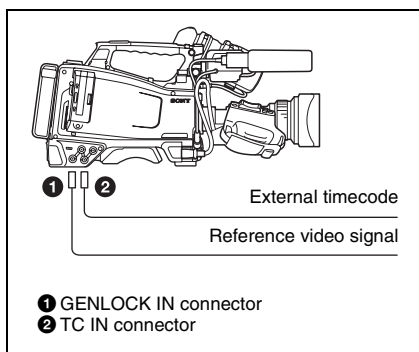

Example 2: Interconnecting a number of camcorders (including one reference camcorder)

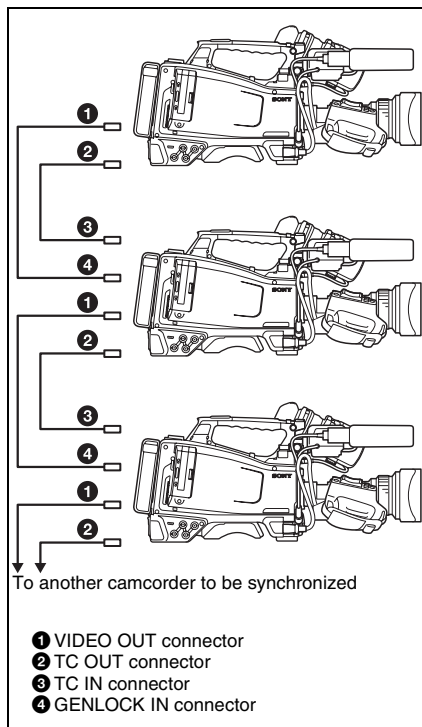

To lock the timecode to an external source

- 1 Turn on the POWER switch.
- 2 Set the PRESET/REGEN/CLOCK switch to PRESET.
- 3 Set the F-RUN/SET/R-RUN switch to F-RUN.
- 4 Set the DISPLAY switch to TC.
- 5 Supply a timecode signal and a reference video signal complying with the SMPTE standard and in proper phase relationship, to the TC IN connector and to the GENLOCK IN connector, respectively.

This operation synchronizes the internal timecode generator with the external timecode. After about 10 seconds, you can disconnect the external timecode without losing the synchronization.

Notes

- When you finish the above procedure, the internal timecode is immediately synchronized with the external timecode and the counter display will show the value of the external timecode. However, wait for a few seconds until the sync generator stabilizes before recording.
- If the frequency of the reference video signal is not the same as the system frequency of the camcorder, the camcorder cannot be correctly genlocked. In such a case, the internal timecode is not correctly synchronized with the external timecode.

User bit settings during timecode synchronization

When the timecode is synchronized, only the time data is synchronized with the external timecode value.

To release the timecode synchronization

First disconnect the external timecode, then set the F-RUN/SET/R-RUN switch to R-RUN.

To change the power supply from the battery pack to an external power supply during timecode synchronization

To maintain a continuous power supply, connect the external power supply to the DC IN connector before removing the battery pack. You may lose timecode synchronization if you remove the battery pack first.

Camcorder synchronization during timecode synchronization

During timecode synchronization, the camcorder is genlocked to the reference video signal input from the GENLOCK IN connector.

Checking Camcorder Settings and Status Information (Status Screens)

The status screens allow you to check camcorder settings and various types of status information. There are five status screens, listed below.

Status screen	Information displayed
CAMERA status	Settings and status information related to shooting
AUDIO status	Settings and status information related to audio input and output
VIDEO status	Settings and status information related to recording and playback
ASSIGN SWITCH status	Names of functions assigned to assignable switches
BATTERY/MEDIA status	Status of the battery mounted on the camcorder and the media status

To display status screens

With no menu is displayed, push the STATUS ON/SEL/OFF switch up to the ON/SEL side. Each push selects the next status screen, in the order given in the table above.

CAMERA status screen

This screen displays settings and status information related to shooting.



White Bal: White balance status

Gain: GAIN switch status

Zoom Speed: Zoom speed set with the lens ZOOM button

Zebra: Zebra status

Skin Tone Detail: Skin details status

AUDIO status screen

This screen displays settings and status information related to audio input and output.

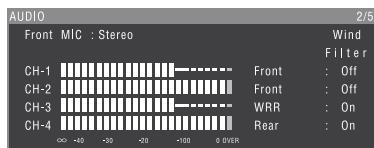

CH-1/CH-2/CH-3/CH-4: Audio level meters and input sources

Wind Filter: Wind filter settings

VIDEO status screen

This screen displays settings and status information related to recording and playback.

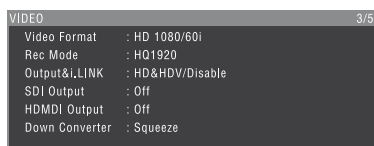

Video Format: Video format

Rec Mode: Recording bit rate (HD mode only)

Output&i.LINK: Output&i.LINK setting and i.LINK usage status

SDI Output: HD/SD SDI OUT connector output setting

HDMI Output: HDMI connector output setting

Down Converter: SD output down converter setting (HD mode only)

ASSIGN SWITCH status screen

This screen displays the names of the functions assigned to assignable switches

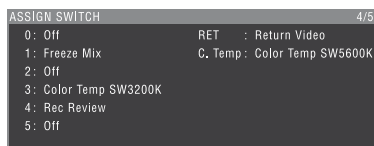

BATTERY/MEDIA status screen

This screen displays the status of the battery mounted on the camcorder and the media status.

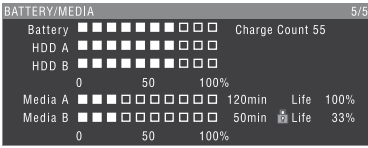

Battery: The remaining battery capacity

Charge Count: The number of times the battery has been charged

HDD A/HDD B: Remaining battery capacity of PHU-60K/120K/120R

Media A/Media B:

- Remaining capacity of media
- Recordable time
- Approximate writable lifetime (Life)
“Life 100%” is shown for unused media.

Handling S×S Memory Cards

This camcorder records video and audio on S×S memory cards (not supplied) loaded into one or both of its memory card slots.

The PHU-60K/120K/120R Professional Hard Disk Unit or MEAD-MS01 Media Adaptor can also be used for recording. For details, refer to the Supplement supplied in the CD-ROM (labeled “Manuals for Solid-State Memory Camcorder”).

About S×S Memory Cards

S×S memory cards that can be used with this camcorder

Use the following Sony S×S memory cards (S×S PRO or S×S-1) with this camcorder.

S×S PRO

- SBP-8 (8 GB)
- SBP-16 (16 GB)
- SBP-32 (32 GB)

S×S-1

SBS-32G1 (32 GB)

Proper operation cannot be guaranteed when memory cards other than S×S PRO and S×S-1 are used.

The memory cards listed above comply with the ExpressCard memory card standard.

- S×S, S×S PRO and S×S-1 are trademarks of Sony Corporation.
- The ExpressCard label and logo are property of the Personal Computer Memory Card International Association (PCMCIA) and are licensed to Sony Corporation. Other trademarks and trade names are the property of their respective owners.

Notes on the use of S×S memory cards

- Recorded data may be lost or corrupted in the following cases.
 - When the camcorder is subjected to shock or vibrations during reading, writing, or formatting of an S×S memory card, and when the camcorder is powered off or an S×S memory card is removed during reading, writing, or formatting
 - When the camcorder is used in an environment subject to static electricity or electric noise
- Do not use or store S×S memory cards in locations that are:
 - Outside the specified environmental ranges
 - Very hot, such as in vehicles parked in the sun during summer, or exposed to direct sunlight, or near heaters
 - Subject to high humidity and corrosion
- When inserting a memory card, insert with the label side facing the correct direction.
- Carry and store S×S memory cards in their cases, and lock the cases securely.

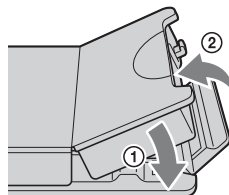

- Guard against accidents and inadvertent data loss by backing up the data stored on S×S memory cards. Sony cannot be responsible for any consequences of damage to or loss of data stored on S×S memory cards.
- Do not attach anything other than the supplied labels in the designated label space. When attaching a label, make sure it does not protrude beyond the label space.

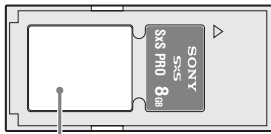

Label space

- Use this camcorder to format SxS memory cards that will be used with this camcorder. When memory cards are formatted on another unit, the format is regarded as an invalid format, making it necessary to format the memory cards again. However, note that the format and delete functions of this camcorder do not completely remove data from memory cards. Before discarding or disposing of a memory card, erase it using commercial data erasure software, or physically destroy it. Sony cannot be responsible for any failure to erase data completely.
- Clip operations may not be possible when the remaining capacity of the media is low. In this case, use a computer to delete unneeded files and try again.
- Open the memory card case completely before storing a card in the case or removing a card from the case.

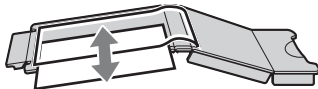

Preventing accidental erasure

You can prevent accidental recording, editing, and deletion of data on an SxS memory card by setting the write protect switch to the WP side.

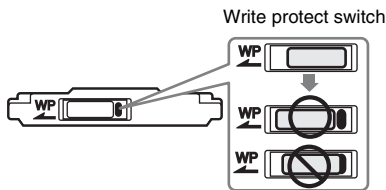

Note

Do not touch the write protect switch while an SxS memory card is loaded in a card slot. Eject the card before setting the write protect switch.

Loading and Ejecting SxS Memory Cards

To load SxS memory cards

- 1 Slide the cover to the left to open.
- 2 Insert an SxS memory card into a card slot.

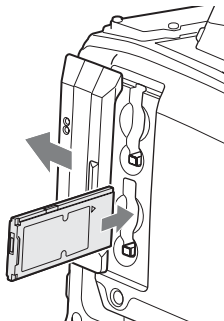

Insert with the label side facing right.

The ACCESS lamp lights in orange, and then lights in green to indicate that the memory card is usable.

- 3 Close the cover.

ACCESS lamp status indications

Card slots A and B each have an ACCESS lamp to indicate the slot status.

Lamp	Slot status
Lights in orange	Accessing the SxS memory card (lights during data reading and writing)
Lights in green	Standby (the loaded SxS memory card is ready for recording or playback)
Not lit	<ul style="list-style-type: none"> • No SxS memory card is loaded. • An unusable card is loaded. • An SxS memory card is loaded, but the other slot is selected.

To eject S×S memory cards

- 1 **Open the cover, and then press the EJECT button to release the lock and pull the button out.**

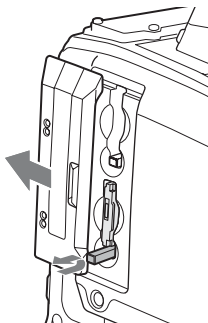

Press the button once to release the lock.

- 2 **Press the EJECT button again to eject the card.**

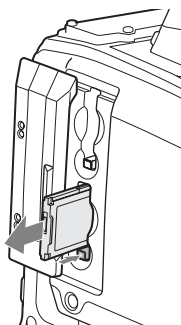

Note

Data integrity cannot be guaranteed if you power the camcorder off or remove a memory card while the card is being accessed. Doing so may corrupt all data recorded on the card. Always make sure that the ACCESS lamp is lit green or not lit before you power the camcorder off or remove a memory card.

Selecting the S×S Memory Card to Use

When S×S memory cards are loaded in both slot A and slot B, you can press the SLOT SELECT button to select the S×S memory card to use.

The camcorder switches automatically to the other card if the selected card becomes full during recording.

Note

The SLOT SELECT button is disabled during playback. Even when pressed, it does not change the selected slot. Button operations are enabled when a thumbnail screen (see page 80) is displayed.

Formatting (Initializing) S×S Memory Cards

When you load an unformatted S×S memory card, or load an S×S memory card that has been formatted to other specifications, a message “Cannot Use Media(A)/Unsupported File System” appears in the viewfinder. In this case, format the memory card in the following way.

Note

S×S memory cards must be formatted on an XDCAM EX device. Cards in other formats cannot be used.

To format (initialize) a memory card

- 1 **Select OPERATION >Format Media in the setup menu (see page 97).**
- 2 **Select [Media(A)] (slot A) or [Media(B)] (slot B).**
- 3 **Turn the MENU knob to select “Execute”, and then press the knob.**
The confirmation message for formatting is displayed on the viewfinder screen.
- 4 **Turn the MENU knob to select “Execute”, and press the knob.**
Execution of the format starts.
During execution of the format, a progress indication appears (%), and the ACCESS lamp lights in orange.
A completion message appears for three seconds when the format finishes.

Recording and playback during format execution

Even during execution of a format, recording and playback are possible using an S×S memory card loaded into the other card slot.

If the format operation fails

A format operation may fail because the SxS memory card is write protected, or because it is not the type of card specified for use with this camcorder.

In this case, an error message appears. Following the instructions in the error message and exchange the card for an SxS memory card that can be used with this camcorder.

Notes

- All data is erased when you format a memory card, including setup files and all of the recorded video data.
- Use the format function of this camcorder to format SxS memory cards for use on this camcorder. The formats of cards formatted on other devices are not recognized as valid formats, making it necessary to format them again on this camcorder.

Checking the Remaining Recording Time

You can check the remaining capacity of the SxS memory cards loaded in the two slots by checking the recording media remaining capacity display in the viewfinder.

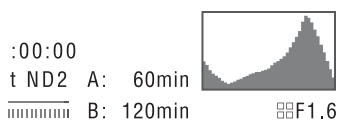

The camcorder calculates the remaining recording time for the media in each slot on the basis of the current video format (recording bit rate), and displays it in units of minutes.

You can also check the remaining time in the BATTERY/MEDIA status screen (*see page 66*).

Note

The  mark appears when a memory card is write protected.

When to exchange SxS memory cards

- The warning message “Media Near Full” appears, the WARNING indicator and the REC indication on the viewfinder screen flash, and the buzzer sounds when the total remaining recording time of the two memory cards falls to five minutes during recording. Exchange one of the cards for media with available recording capacity.

- If you continue recording, the message “Media Full” appears and recording stops when the total remaining recording time falls to 0.

Note

About up to 600 clips can be recorded on one SxS memory card.

The display of remaining recording time changes to “0” and the message “Media Full” appears when the clip limit is reached.

Restoring SxS Memory Cards

If for any reason an error should occur in a memory card, the card must be restored before use.

When you load an SxS memory card that needs to be restored, a message appears in the viewfinder to ask whether you want to restore it.

To restore a card

Turn the MENU knob to select [Execute], and then press the knob.

The restoration starts.

During the restoration, an execution message appears, the progress is displayed (%), and the ACCESS lamp lights in orange.

When the restoration finishes, a completion message is displayed for three seconds.

If restoration fails

- Write protected SxS memory cards and cards on which memory errors have occurred cannot be restored. A warning message appears for such cards. Follow the instructions in the message and unprotect the card or replace it with another card.
- SxS memory cards on which memory errors have occurred may become usable if they are reformatted.
- In some cases, some clips can be restored while others cannot. The restored clips can be played normally.
- If the message “Could not Restore Some Clips” keeps appearing after repeated attempts at restoration, it may be possible to restore the SxS memory card with the following procedure.

- ① Use the camcorder’s copy function (*see page 87*) or the XDCAM EX Clip Browsing Software (*see page 143*) to copy the required clips to another SxS memory card.

- ② Format the unusable S×S memory card on the camcorder.
- ③ Copy the required clips back to the newly formatted S×S memory card.

Recording and playback during restoration

Even while restoration is in progress, you can record and play an S×S memory card in the other card slot.

Basic Operations

This section explains the basic shooting and recording procedures.

Before starting to shoot, inspect the camera system to verify that it is operating properly.

- 1 Attach a fully charged battery pack** (*see page 33*).
- 2 Load one or two S×S memory cards** (*see page 68*).
If you load two cards, the camcorder switches automatically to the second card when the first card becomes full.
- 3 Set the camcorder's POWER switch** (*see page 14*) to ON.
- 4 Make the following settings.**
Marker display: On (*see page 103*)
Iris: Auto (*see page 57*)
Zoom: Auto (*see page 58*)
Camera output: Select the picture currently being shot (camera picture), and turn the DCC function on (*see page 18*).
Timecode advance mode: F-RUN (Free Run) or R-RUN (Rec Run) (*see page 62*)
Audio input channel selection: Auto (*see page 24*)
- 5 Push the AUTO W/B BAL switch to the BLACK side to adjust the black balance** (*see page 51*).
- 6 Select a filter according to the lighting conditions, and adjust the white balance** (*see page 52*).
- 7 Point the camcorder at the subject, and adjust the focus** (*see page 58*) and zoom.
- 8 If you are using the electronic shutter, select an appropriate shutter mode and speed** (*see page 55*).
- 9 Do one of the following to start recording.**

- Press the REC START button (*see page 16*).
- Press the VTR button on the lens (*see page 27*).
- Turn on the assignable switch to which the Rec function has been assigned (*see page 132*).

During recording, the TALLY indicators, the tally indicator on the front panel of the viewfinder, and the REC indication on the viewfinder screen light. Adjust the zoom and focus as required.

Notes

- Never remove the battery pack while the camcorder is recording (while an ACCESS lamp is lit). Doing so risks the loss of several seconds of data before the recording was interrupted, because internal processing will not end normally.
- The playback control buttons (EJECT, F REV, F FWD, NEXT, PREV, PLAY/PAUSE, STOP) do not function during recording.

10 To stop recording, perform one of the operations listed in step 9.

The TALLY indicators, the tally indicator on the front panel of the viewfinder, and the REC indication on the viewfinder screen go out, and camcorder enters recording standby (STBY) mode.

A clip is created from the video shot between steps 9 and 10.

To check the recording (recording review)

With the camcorder in recording standby (STBY) mode, turn on the assignable switch to which the Rec Review function or the Freeze Mix function has been assigned (*see page 131*).

The camcorder plays the entire last clip, or the last few seconds of that clip (3 seconds or 10 seconds), and then returns to standby mode.

You can use MAINTENANCE >Camera Config >Rec Review in the setup menu (*see page 122*) to change the playback time.

When the Rec Review function is assigned to the RET button on the lens, you can also conduct a review by using the RET button.

11 Repeat steps 9 and 10 to continue recording.

With each repetition, another clip is created on the memory card.

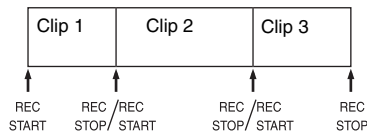

Notes

- You cannot resume recording for about one second after stopping recording.
- The maximum number of clips that can be recorded on one memory card is 600. Even if the memory card has enough free capacity to record more clips, when 600 clips have been recorded, no further recording is possible.

Notes on Clips

The XDCAM EX-series products limit the maximum file size of an HD clip to 4 GB and that of an SD clip to 2 GB.

If you continue recording for an extended period, recorded materials may be segmented into multiple files, depending on the file size (the maximum number of partitions is 99).

The camcorder regards continuous recording as one clip even if it has been segmented into multiple files.

Playing Recorded Clips

When the camcorder is in standby (STBY) mode, you can play all or part of the most recently recorded clip (*see page 72*).

1 Insert the S×S memory card to play (*see page 68*).

2 Press the PREV button (*see page 20*) or the F REV button (*see page 20*) to cue up the clip to play.

3 Press the PLAY/PAUSE button.

The PLAY/PAUSE indicator lights, and the playback picture appears in the viewfinder.

To pause the playback

Press the PLAY/PAUSE button.

The PLAY/PAUSE indicator flashes during pause.

Press the button again to return to playback mode.

To play at high speed

Press the F FWD button (*see page 20*) or the F REV button (*see page 20*).

To return to normal playback, press the PLAY/PAUSE button.

To switch between memory cards

When two memory cards are loaded, press the SLOT SELECT button (*see page 23*) to select the active slot.

It is not possible to switch between memory cards during playback.

To end playback

Press the STOP button: Playback stops, and the camcorder enters E-E mode.

Press the THUMBNAIL button: Playback stops, and a thumbnail screen (*see page 80*) appears in the viewfinder.

Playback also stops and the timecode screen appears in the viewfinder when you start recording during playback, and when you eject an S×S memory card.

Deleting Recorded Clips

You can use the assignable switches to delete the last recorded clips (Last Clip DEL function).

You can also use the THUMBNAIL menu to delete all recorded clips (All Clips DEL function) or to delete selected clips. For details, see “Deleting Clips” (page 88).

- 1 Turn on the assignable switch to which the Last Clip DEL function has been assigned (*see page 132*).**
A confirmation message appears.
- 2 Turn the MENU knob to select [Execute], and then press the knob. Or use the \uparrow or \downarrow button to select [Execute], and then press the SET button.**

Advanced Operations

Recording Shot Marks

On this camcorder, two types of shot marks are available in HD mode. You can record them at user-specified positions to make it easier for editors to cue up those positions. You can record up to 127 shot marks per clip.

Note

Shot marks cannot be recorded in SD mode.

You can also use the THUMBNAIL menu to add and delete shot marks in clips. For details, see “Adding and Deleting Shot Marks (HD Mode Only)” (page 90).

To record shot marks

Do one of the following.

- Turn on an assignable switch to which Shot Mark 1 or Shot Mark 2 has been assigned (*see page 131*).
- If Lens RET has been assigned to the RET button on the lens, operate as follows.

To record Shot Mark 1: Press the RET button once.

To record Shot Mark 2: Press the RET button twice in quick succession.

When a shot mark is recorded, a “Shot Mark 1” or “Shot Mark 2” indication appears in the viewfinder for about three seconds near the timecode indication.

Setting OK Marks

To make it easier for editors to select good clips, you can set OK marks in clips recorded in HD mode.

Notes

- OK marks cannot be set in SD mode.
- OK marks cannot be set or deleted during recording or playback.

You can also use the THUMBNAIL menu to add and delete OK marks in previously recorded clips. For

details, see “Adding and Deleting OK Marks (HD Mode Only)” (page 87).

To set OK marks

After recording of a clip ends, turn on the assignable switch to which the OK Mark function has been assigned (see page 131). If the OK Mark function has been assigned to the RET button on the lens, press RET button on the lens.

An OK mark is set in the most recently recorded clip, and an “OK Mark” indication appears in the viewfinder for about three seconds near the timecode indication.

To delete OK marks

1 If an OK mark has been set in the most recently recorded clip, turn on the assignable switch to which the OK Mark function has been assigned (see page 131).

If the OK Mark function has been assigned to the RET button on the lens, press RET button on the lens.

A confirmation message appears.

2 Turn the MENU knob to select [Execute], and then press the knob.

The OK mark is deleted from the most recently recorded clip.

Starting to Record from Pre-stored Video (Picture Cache Function)

The camcorder is equipped with enough internal memory to pre-store up to 15 seconds of video and audio data in a picture cache. This allows you to begin recording a specified number of seconds in advance of the time when you press a recording start button.

Selecting picture cache mode and setting the picture cache time

Before recording in picture cache mode, you must select picture cache mode and set the picture cache time (the number of seconds of video and audio data stored to memory) in the OPERATION menu.

The picture cache time determines how far in advance you can start recording, counting back in seconds from the operation that starts recording.

Note that it may not be possible to start this far in advance in the special cases explained in the following notes.

Notes

- Storage of picture data to memory begins when you select picture cache mode. Therefore, if you start recording immediately after selecting picture cache mode, the picture data from before the selection is not recorded.
- No data is recorded to picture cache memory during playback or recording review and display of thumbnails. It is not possible to record picture data from the time you were conducting playback or a recording review.

To select picture cache mode and set the picture cache time

Notes

- Picture cache recording is not possible in Frame Rec, Interval Rec, and Slow & Quick Motion mode. The camcorder exits Frame Rec, Interval Rec, or Slow & Quick Motion mode whenever you select picture cache mode. The camcorder exits picture cache mode automatically whenever you select Frame Rec, Interval Rec, or Slow & Quick Motion mode.
- The data stored in picture cache memory is cleared when you change the system settings, for example by selecting a different video format. Picture data from before the change is not recorded even if you start recording immediately after the change. The camcorder exits picture cache mode automatically.
- It is not possible to set the picture cache time during recording.

1 In the setup menu, select OPERATION >Rec Function >Picture Cache Rec.

For menu operations, see “Basic Setup Menu Operations” (page 94).

2 Turn the MENU knob to select [On], and then press the knob.

3 Select [P. Cache Rec Time], turn the MENU knob to select the desired picture cache time, and then press the knob.

You can select from 0-2sec, 2-4sec, 4-6sec, 6-8sec, 8-10sec, 10-12sec, 12-14sec, and 13-15sec.

Once made, picture cache mode settings remain in effect until changed.

Instead of carrying out steps 1 and 2, you can also select picture cache mode by using an assignable

switch to which the Picture Cache function has been assigned (*see page 131*).

Camcorder data handling while recording in picture cache mode

Recording procedures in picture cache mode are basically the same as normal recording procedures. However, note the following differences with respect to how the camcorder handles video, time, and output data.

- If you start recording while the media is being accessed, the start point of the video that is actually recorded may be later than the currently specified picture cache time. Because the delay increases as the number of recorded clips increases, you should avoid rapid start-and-stop recording operations in picture cache mode.
- Regardless of the setting of the F-RUN/SET/R-RUN switch, the advance mode of the internal timecode generator is always F-RUN.
- In picture cache mode, you cannot set time data by setting the F-RUN/SET/R-RUN switch to SET.

To set time data, exit picture cache mode.

- If the remaining free capacity of the media in the currently selected slot is less than the picture cache time, and the media in the other slot has enough remaining capacity, then data is recorded to the media in the other slot. However, no data is recorded when there is no media in the other slot, and when the media in the other slot does not have enough remaining capacity. (A message appears in the viewfinder to inform you that there is not enough remaining capacity.)
- Shot marks are not recorded if they are set before the recording start operation.
- When you select a video format that supports i.LINK HDV output and play a clip that was recorded in picture cache mode, two or more frames with the same picture and timecode may follow on each other.
- i.LINK output is possible during picture cache recording. However, the picture cache time is limited.

If power is lost during recording

- If you set the camcorder's POWER switch to OFF, the camcorder is powered off automatically after a few seconds, during which the media is accessed to record the video and audio data stored in the camcorder's memory up to that point.

- If power is lost because the battery was removed, the DC cable was disconnected, or the power was turned off on the AC adaptor side, then the video and audio data stored in memory is lost. The data stored in memory is not recorded. Be careful to avoid this when exchanging the battery.

Recording Time-lapse Video (Interval Rec Function)

The camcorder's Interval Rec function allows you to capture time-lapse video to the camcorder's internal memory. This function is an effective way to shoot slow-moving subjects. When you start recording, the camcorder automatically records a specified number of frames at a specified interval time.

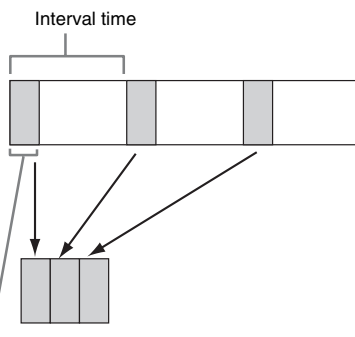

Number of frames in one take

A pre-lighting function is available when Interval Rec is enabled. This function automatically turns on a video light before recording starts, which allows you to record pictures under stable light and color temperature conditions.

Interval Rec settings and shooting

Notes

- The Interval Rec function cannot be used at the same time as the picture cache, Frame Rec, or Slow & Quick Motion function. When you select Interval Rec mode, the picture cache, Frame Rec, and Slow & Quick Motion functions are disabled. When you select picture cache, Frame Rec, or Slow & Quick Motion mode, the Interval Rec function is disabled.

- The data stored in picture cache memory is cleared when you change the system settings, for example by selecting a different video format. Picture data from before the change is not recorded even if you start recording immediately after the change. The camcorder exits picture cache mode automatically.
- Interval Rec settings cannot be changed during recording.
- Interval Rec is disabled when the following formats are selected.
 - SP 1440/59.94i or SP 1440/50i, when the output setting is HD and OPERATION >Input/Output >i.LINK I/O in the setup menu is set to [Enable]
 - SP 1440/23.98P (pull-down recording)
 - Other than HQ 1920/23.98P or HQ 1280/23.98P, when the output setting is SD and OPERATION >Input/Output >i.LINK I/O in the setup menu is set to [Enable]

To make Interval Rec settings

1 Select OPERATION >Rec Function >Interval Rec in the setup menu.

For menu operations, see “Basic Setup Menu Operations” (page 94).

2 Turn the MENU knob to select [On], and then press the knob.

The camcorder enters Interval Rec mode, the “Interval” indication on the viewfinder screen flashes.

3 Select [Number of Frames], turn the MENU knob to select the number of frames to record in one take, and then press the knob.

You can select from 1, 3, 6, 9 (or from 2, 6, 12 when the video format setting is 720/59.94P or 720/50P).

4 Select [Interval Time], turn the MENU knob to select the desired interval, and then press the knob.

You can select 1 to 10/15/20/30/40/50 sec, 1 to 10/15/20/30/40/50 min, 1 to 4/6/12/24 hour.

5 As required, select [Pre-Lighting], turn the MENU knob to select the length of lighting time before recording starts, and then press the knob.

You can select 1 to 10/15/20/30/40/50 sec, 1 to 10/15/20/30/40/50 min, 1 to 4/6/12/24 hour.

Notes

- If you want to turn the video light on before the start of recording, set the camcorder’s LIGHT switch to [AUTO]. The video light’s switch must also be turned on. When this is done, the video light turns on and off automatically. However, the video light remains lit when the time that it is off is five seconds or less.
- If you set the LIGHT switch to [MANUAL] and turn the video light’s switch on, the video light is always lit. (It does not go on and off automatically.)

The camcorder exits Interval Rec mode when it is powered off, but the number of frames, interval time, and pre-lighting settings are maintained. You do not need to set them again the next time you shoot in Interval Rec mode.

To shoot in Interval Rec mode

Make the settings and preparations described in “Basic Operations” (page 71), secure the camcorder so that it does not move, and begin shooting.

When recording starts, the “Interval” indication in the viewfinder changes from flashing to lit, and “INT REC” and “INT STBY” appear alternatively at the position of the REC indication. The TALLY indicators and the tally indicator on the front panel of the viewfinder light as they do during normal recording.

If you are using the pre-lighting function, the video light comes on before recording starts.

To stop shooting

Stop the recording.

When shooting ends, the video data stored in memory up to that point is written to the media.

To exit Interval Rec mode

Do one of the following.

- Set the POWER switch to OFF.
- With the camcorder in recording standby mode, set OPERATION >Rec Function >Interval Rec in the setup menu to “Off”.

Limitations during recording

- The i.LINK (HDV/DV) connector cannot be used.
- Regardless of the setting of the F-RUN/SET/R-RUN switch, the advance mode of the internal timecode generator is always F-RUN.
- Audio cannot be recorded.
- Recording review is not possible.

- If you press the SLOT SELECT button, the camcorder completes recording of the specified number of frames, creates a clip, and switches to the other media.
- Genlock is not possible.

If power is lost during recording

- If you set the camcorder's POWER switch to OFF, the camcorder is powered off automatically after a few seconds, during which the media is accessed to record the video and audio data stored in the camcorder's memory up to that point.
- If power is lost because the battery was removed, the DC cable was disconnected, or the power was turned off on the AC adaptor side, then the video and audio data shot up to that point may be lost (maximum 10 seconds). Be careful to avoid this when exchanging the battery.

Shooting Stop Motion Animations (Frame Rec Function)

The Frame Rec function is useful for shooting stop motion animations, such as animations with puppets or clay figures.

Each time that you press the recording start button, the camcorder shoots a specified number of frames and then stops.

Frame Rec settings and shooting

Notes

- The Frame Rec function cannot be used at the same time as the picture cache, Interval Rec, or Slow & Quick Motion function. When you select Frame Rec mode, the picture cache, Interval Rec, and Slow & Quick Motion functions are disabled. When you select picture cache, Interval Rec, or Slow & Quick Motion mode, the Frame Rec function is disabled.
- The data stored in memory is cleared when you change the system settings, for example by selecting a different video format. Picture data from before the change is not recorded even if you start recording immediately after the change. The camcorder exits Frame Rec mode automatically.
- Frame Rec settings cannot be changed during recording.
- Frame Rec is disabled when the following formats are selected.
 - SP 1440/59.94i or SP 1440/50i, when the output setting is HD and OPERATION >Input/Output >.LINK I/O in the setup menu is set to Enable

- SP 1440/23.98P (pull-down recording)
- Other than HQ 1920/23.98P or HQ 1280/23.98P, when the output setting is SD and OPERATION >Input/Output >.LINK I/O in the setup menu is set to Enable

To make Frame Rec settings

1 Select OPERATION >Rec Function >Frame Rec in the setup menu.

For menu operations, see “Basic Setup Menu Operations” (page 94).

2 Turn the MENU knob to select [On], and then press the knob.

The camcorder enters Frame Rec mode, the “Frame Rec” indication on the viewfinder screen flashes.

3 Select [Number of Frames], turn the MENU knob to select the number of frames to record in one take, and then press the knob.

You can select from 1, 3, 6, 9 (or from 2, 6, 12 when the video format setting is 720/59.94P or 720/50P).

The camcorder exits Frame Rec mode when it is powered off, but the setting for the number of frames setting is maintained. You do not need to set it again the next time you shoot in Frame Rec mode.

To shoot in Frame Rec mode

Make the settings and preparations described in “Basic Operations” (page 71), secure the camcorder so that it does not move, and begin shooting.

When recording starts, the “Frame Rec” indication in the viewfinder changes from flashing to lit, and “FRM REC” and “FRM STBY” appear alternatively at the position of the REC indication. The TALLY indicators and the tally indicator on the front panel of the viewfinder light as they do during normal recording.

To stop shooting

Stop the recording.

When shooting ends, the video data stored in memory up to that point is written to the media.

To exit Interval Rec mode

Do one of the following.

- Set the POWER switch to OFF
- With the camcorder in recording standby mode, set OPERATION >Rec Function >Interval Rec in the setup menu to “Off”.

Limitations during recording

- The i.LINK (HDV/DV) connector cannot be used.
- Regardless of the setting of the F-RUN/SET/R-RUN switch, the advance mode of the internal timecode generator is always R-RUN.
- Audio cannot be recorded.
- Recording review is not possible.
- If you press the SLOT SELECT button, the camcorder completes recording of the specified number of frames, creates a clip, and switches to the other media.
- Genlock is not possible.

If power is lost during recording

- If you set the camcorder’s POWER switch to OFF, the camcorder is powered off automatically after a few seconds, during which the media is accessed to record the video and audio data stored in the camcorder’s memory up to that point.
- If power is lost because the battery was removed, the DC cable was disconnected, or the power was turned off on the AC adaptor side, then the video and audio data shot up to that point may be lost (maximum 10 seconds). Be careful to avoid this when exchanging the battery.

Shooting with Slow & Quick Motion

When the camcorder is in HD mode and the video format (*see page 50*) is set to one of the formats listed below, you can specify a recording frame rate that is different from the playback frame rate.

When the Country setting is NTSC: HQ 1920/29.97P, HQ 1920/23.98P, HQ 1280/59.94P, HQ 1280/29.97P, HQ 1280/23.98P

When the Country setting is PAL: HQ 1920/25P, HQ 1280/50P, HQ 1280/25P

By shooting with a frame rate that differs from the playback frame rate, you can obtain slow and quick motion effects that are smoother than low-speed or high-speed playback of content recorded at the normal frame rate.

Example

When the video format is HQ 1280/23.98P, you can obtain quick-motion effects by setting the frame rate to 1 to 23, and obtain slow-motion effects by setting the frame rate to 25 to 60.

Slow & Quick Motion settings and shooting

Notes

- The Slow & Quick Motion function cannot be used at the same time as the picture cache, Interval Rec, or Frame Rec function. When you select Slow & Quick Motion mode, the picture cache, Interval Rec, and Frame Rec functions are disabled. When you select picture cache, Frame Rec, or Interval Rec mode, the Slow & Quick Motion function is disabled.
- Slow & Quick Motion is disabled when the slow shutter function (viewfinder display “SLS”) function is enabled. The slow shutter function is disabled when the Slow & Quick Motion function is enabled.
- Slow & Quick Motion is disabled when OPERATION >Input/Output >i.LINK I/O in the setup menu is set to [Enable]. When Slow & Quick Motion is enabled, i.LINK I/O is fixed as [Disable].
- Slow & Quick Motion settings cannot be changed during recording.

To make Slow & Quick Motion settings

1 Select OPERATION >Rec Function > Slow & Quick in the setup menu.

For menu operations, see “Basic Setup Menu Operations” (page 94).

2 Turn the MENU knob to select [On], and then press the knob.

The camcorder enters Slow & Quick Motion mode, and the “S&Q Motion” indication in the viewfinder flashes.

3 Select [Frame Rate], turn the MENU knob to select the recording frame rate, and then press the knob.

The setting range for the frame rate is as follows.

System lines	Frame rate
1080	1 to 30
720	1 to 60

When you finish making these settings, the system frequency and the frame rate appear at the top of the viewfinder screen. You can change the frame rate while viewing the display in the

viewfinder by turning the MENU knob, or by using the \uparrow or \downarrow button and then pressing the SET button.

The Slow & Quick Motion mode setting and the frame rate are retained even after the camcorder is powered off.

To shoot in Slow & Quick Motion mode

Shoot as described in “Basic Operations” (page 71).

When recording starts, the “S&Q Motion” indication in the viewfinder changes from flashing to lit, and the REC indication lights (the indication displays “S&Q REC”). The TALLY indicators and the tally indicator on the front panel of the viewfinder light as they do during normal recording.

To stop shooting

Stop the recording.

Note

It takes longer than normal for recording to stop when Frame Rate is set to a low value (for a slow frame rate).

To exit Slow & Quick Motion mode

With the camcorder in recording standby mode, set OPERATION >Rec Function > Slow & Quick in the setup menu to “Off”.

Limitations during recording

- The i.LINK (HDV/DV) connector cannot be used.
- Regardless of the setting of the F-RUN/SET/R-RUN switch, the advance mode of the internal timecode generator is always R-RUN.
- Audio cannot be recorded when the recording and playback frame rates differ.
- Recording review is not possible.
- If you change the recording frame rate to a value faster than the current shutter speed, the shutter speed is changed to the slowest value for which shooting is possible.

Example: If the frame rate is 32 and the shutter speed is $1/40$, and you change the frame rate to 55, then the shutter speed is changed to $1/60$.

If it is not possible to select a shutter speed that is slower than the recording frame rate.

- Genlock is not possible.

Framing Shots with the Freeze Mix Function

The freeze mix function allows you to temporarily overlap a still image (freeze picture) from a clip shot in HD mode onto the current camera picture. This makes it easier to frame the shot.

Note

The freeze mix function is not available in the following cases.

- When the recording format is SP 1440/23.98P
- When the video formats of the recorded picture and the camera picture differ
- When you are shooting in Slow & Quick Motion mode or slow shutter mode
- When there is i.LINK input

To display a freeze mix picture

1 Play a clip or conduct a recording review of a clip with the same format as the camera picture.

2 Display the picture that you want to use as the frame, and then turn on the assignable switch to which the Freeze Mix function has been assigned.

The recording review picture is frozen and overlaps the camera picture.

Note

The following functions are disabled at the freeze mix times.

- Menu operations
- During Focus Mag display
- Marker display
- Zebra display
- Peaking display
- Skin tone details display

To cancel the freeze mix display

Do one of the following.

- Press an assignable switch again to which the Freeze Mix function has been assigned. The freeze mix display is canceled and the display returns to the normal camera picture.
- Start recording (see page 131). Normal recording starts.

Clip Playback

A thumbnail screen appears if you press the THUMBNAIL button in E-E or playback mode. Thumbnail screens display lists of the clips stored on S×S memory cards in the form of index pictures. (A message appears if you insert a memory card that contains no clips.)

You can select any clip (*see page 82*) in a thumbnail screen and start playback of that clip (*see page 82*).

Thumbnail Screen

In thumbnail screens, the timecode of the index picture appears beneath the thumbnail for each clip. (An OK mark also appears when a clip has been marked with an OK mark.)

Note

Normal thumbnail screens display SD clips only or HD clips only, even if the S×S memory card contains clips in both formats. You can select the format to display by selecting a mode with OPERATION >Format >HD/SD (*see page 96*) in the setup menu.

If you want to display all recorded clips, regardless of the HD/SD mode, switch to the all clips thumbnail screen.

However, it is not possible to start playback from the all clips thumbnail screen (*see page 85*).

HD mode thumbnail screen

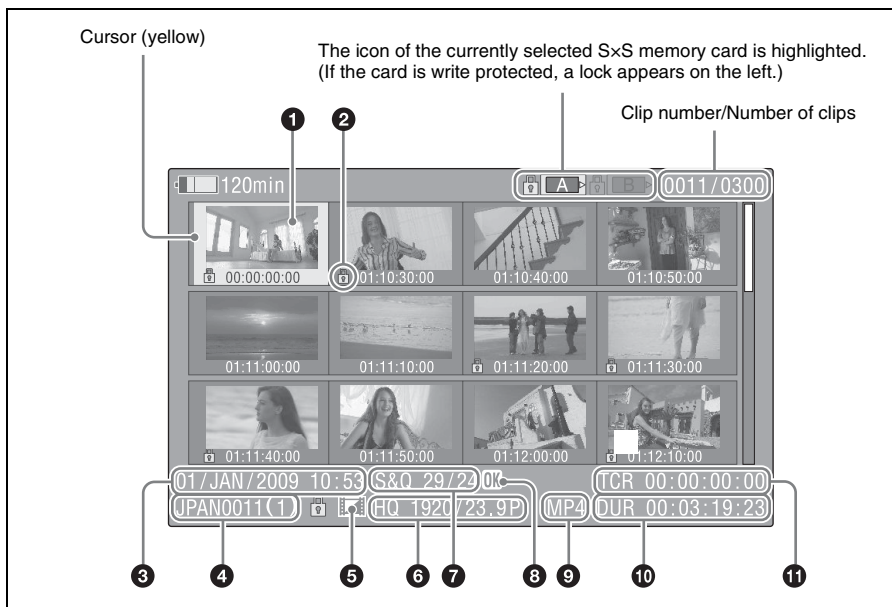

1 Index picture

When a clip is recorded, its first frame is set automatically as the index picture. You can change to index picture to any frame (*see page 90*).

2 Lock mark

Indicates the selected clip is marked with an OK mark and protected.

3 Date and start time of recording**4 Clip name****5 Independent AV file icon**

This appears only when a clip is an independent AV file. SxS memory cards may contain independent files that have been added directly from a computer. Because independent files lack the associated management files, some operations and information displays may not be available.

6 Video format of recording**7 Special recording information**

This displays the mode of clips that have been recorded in a special mode (Slow & Quick Motion, Interval Rec, Frame Rec). For Slow & Quick Motion clips, the frame rates are displayed to the right as [Recording frame rate/Playback frame rate] fps.

8 OK mark

An OK mark appears only when the clip has been marked with an OK mark (*see page 87*).

9 File format

Indicates the file format of the selected clip (MP4).

10 Clip duration**11 Timecode**

This is the timecode of the index picture.

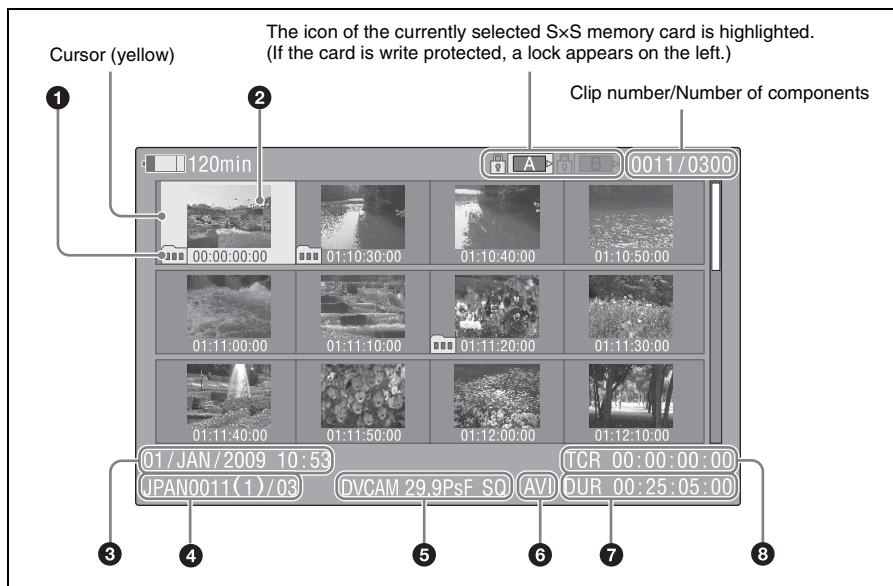
SD mode thumbnail screen**1 Take mark**

Indicates that the file size is larger than 2 GB, and that the clip has been split before being saved. You can check the segment files on the expand thumbnail screen (*see page 88*).

2 Index picture

When a clip is recorded, its first frame is set automatically as the index picture.

3 Date and start time of recording**4 Clip name/Number of components**

The number after the clip name (delimited by /) is the number of components. This appears only for clips larger than 2 GB in size, which have been split into smaller files for storage.

5 Video format of recording**6 File format**

Indicates the file format of the selected clip (AVI).

7 Clip duration**8 Timecode**

This is the timecode of the index picture.

To switch between S×S memory cards

When two S×S memory cards are loaded, you can switch between them by pressing the SLOT SELECT button.

Note

Switching between memory cards is possible only in the normal thumbnail screen, the OK clip thumbnail screen, or the all clips thumbnail screen, or when you have pressed the STOP button to display the camera picture.

To hide the thumbnail screen

Press the THUMBNAIL button.

Playing Clips**To select clip thumbnails**

Do one of the following to move the yellow cursor to the clip that you want to select.

- Press an arrow button (↑, ↓, ←, →).
- Turn the MENU knob.
- Press the PREV or NEXT button.

To select the first thumbnail

With the F REV button held down, press the PREV button.

To select the last thumbnail

With the F FWD button held down, press the NEXT button.

To play clips sequentially starting from a selected clip**1 Select the thumbnail of the clip that you want to play first.****2 Press the PLAY/PAUSE button.**

Play begins from the top of the selected clip.

Play continues through all clips after the selected clip.

When the last clip has been played to the end, the camcorder enters pause (still image) mode at the last frame of the last clip.

Press the THUMBNAIL button to return to the thumbnail screen.

Notes

- There may be momentary picture breakup or still image display at the transition from one clip to another. During this time, the playback controls and the THUMBNAIL button cannot be operated.
- When you select a clip in the thumbnail screen and begin playback, there may be momentary picture breakup at the top of the clip. To view the top of the clip without breakup, put the camcorder into playback mode, pause, use the PREV button to return to the top of the clip, and start playback again.
- On S×S memory cards that contain both HD-mode and SD-mode clips, you cannot play all clips in sequence. For example, while an HD mode thumbnail screen is displayed, only HD mode clips are played in sequence.

To pause playback

Press the PLAY/PAUSE button.

The PLAY/PAUSE indicator flashes while playback is paused.

Press the button again to return to playback mode.

To play at high speed

Press the F FWD button (*see page 20*) or the F REV button (*see page 20*).

To return to normal playback, press the PLAY/PAUSE button.

To stop playback

Press the STOP button: Playback stops and the camcorder enters E-E mode.

Press the THUMBNAIL button: Playback stops and the thumbnail screen (*see page 80*) appears in the viewfinder.

Playback also stops if you eject the memory card. In this case, the camera picture appears in the viewfinder.

To cue up clips

To return to the top of the current clip

Press the PREV button.

- During playback or F FWD, this jumps to the top of the current clip and starts playback.
- During F REV or pause, this jumps to the top of the current clip and displays a still image.
- Each subsequent press of the button moves to the previous clip.

To play from the top of the first clip

Simultaneously press the PREV and F REV buttons. This jumps to the top of the first clip on the S×S memory card.

To jump to the top of the next clip

Press the NEXT button.

- During playback or F FWD, this jumps to the top of the next clip and starts playback.
- During F REV or pause, this jumps to the top of the next clip and displays a still image.
- Each subsequent press of the button moves to the next clip.

To play from the top of the last clip

Simultaneously press the NEXT and F FWD buttons. This jumps to the top of the last clip on the S×S memory card.

To add a shot mark during playback (HD mode only)

You can add shot marks to clips during playback by using the same method used during recording (see page 73).

Notes

- Shot marks cannot be recorded when the S×S memory card is write protected.
- Shot marks cannot be added at the first or last frame of a clip.

Using Thumbnails to Search Inside Clips

You can switch a thumbnail screen to the following thumbnail search screens, which allow you quickly find the clips you want.

- Expand thumbnail screen
- Shot mark thumbnail screen (HD mode only)

Like the normal thumbnail screen and the OK clip thumbnail screen, these screens allow you to

select clip thumbnails (see page 82) and to start clip playback (see page 82).

To search for scenes in clips with the expand thumbnail screen

The expand thumbnail screen is convenient when you want to find and cue up a specific scene in a long clip.

To display the expand thumbnail screen, select a clip in the thumbnail screen and press the EXPAND button (see page 20) or select THUMBNAIL >Thumbnail View >Forward Expansion in the setup menu. The selected clip is displayed as follows.

HD mode: The clip is divided into 12 equally-sized blocks, and a thumbnail of the first frame in each block is displayed.

SD mode: Only in the case of clips that have been split into partial files because the file size was larger than 2 GB, a thumbnail of the first frame of each partial file is displayed.

This helps you to quickly cue up to a desired scene in a clip of long duration.

See “Displaying the Expand Thumbnail Screen” (page 88) for more information about the expand thumbnail screen.

To search for shot marks in clips with the shot mark thumbnail screen (HD mode)

When a clip contains one or more shot marks, you can easily find them with the shot mark thumbnail screen. The shot mark thumbnail screen displays a thumbnail of each shot mark frame in the clip. To display the shot mark thumbnail screen, press the ESSENCE MARK button (see page 22) or select THUMBNAIL >Thumbnail View >Essence Mark Thumbnail in the setup menu.

See “Displaying the Shot Mark Thumbnail Screen (HD Mode Only)” (page 89) for more information about the shot mark thumbnail screen.

Thumbnail Operations

You can use the THUMBNAIL menu to perform various operations on clips, to check clip properties, and to change clip metadata.

THUMBNAIL Menu Configuration

Menu items	Sub-items	Description
Clip Properties	—	Displays detailed properties (<i>see page 86</i>)
Set Index Picture ^{a)}	—	Changes index pictures in the expand thumbnail screen or the shot mark thumbnail screen (<i>see page 90</i>)
Thumbnail View	Forward Expansion	<ul style="list-style-type: none"> • Displays the expand thumbnail screen (<i>see page 88</i>) • In the expand thumbnail screen, increases the number of divisions (<i>see page 89</i>)
	Back Expansion	In the expand thumbnail screen, decreases the number of divisions
	Essence Mark Thumbnail ^{a)}	Displays the shot mark thumbnail screen (<i>see page 89</i>)
	Clip Thumbnail	Displays the normal thumbnail screen
	All Clip Thumbnail	Displays the all clips thumbnail screen (<i>see page 85</i>)
Set Shot Mark ^{a)}	Add Shot Mark1	In the expand thumbnail screen or the shot mark thumbnail screen, adds a Shot Mark1 mark (<i>see page 90</i>)
	Delete Shot Mark1	In the expand thumbnail screen or the shot mark thumbnail screen, deletes a Shot Mark1 mark (<i>see page 90</i>)
	Add Shot Mark2	In the expand thumbnail screen or the shot mark thumbnail screen, adds a Shot Mark2 mark (<i>see page 90</i>)
	Delete Shot Mark2	In the expand thumbnail screen or the shot mark thumbnail screen, deletes a Shot Mark2 mark (<i>see page 90</i>)
Add OK Mark ^{a)}	—	Adds an OK mark and protects a clip (<i>see page 87</i>)
Delete OK Mark ^{a)}	—	Deletes an OK mark and unprotects a clip (<i>see page 87</i>)
Copy Clip	—	Copies a clip (<i>see page 87</i>)
Delete Clip	—	Deletes a clip (<i>see page 88</i>)
Divide Clip ^{a)}	—	Divides a clip (<i>see page 91</i>)
Filter Clips ^{a)}	—	Displays the OK clip thumbnail screen (<i>see page 85</i>)
Copy All Clips	Execute/Cancel	Copies all clips (<i>see page 88</i>)
Delete All Clips	Execute/Cancel	Deletes all unprotected clips (<i>see page 88</i>)

a) HD mode only

Basic THUMBNAIL Menu Operations

See “Basic Setup Menu Operations” (page 94) for information about menu operations.

To display the THUMBNAIL menu

- 1 Set the MENU ON/OFF switch to ON, or press the MENU button.
- 2 Turn the MENU knob to select “TH”, and then press the knob. Or press the \uparrow or \downarrow button to select “TH”, and then press the SET button.
The THUMBNAIL menu appears.



To hide the THUMBNAIL menu, press the MENU button again.

To select menu items and sub-items

Do one of the following.

- Turn the MENU knob to select an item or sub-item, and then press the knob.
- Press the arrow buttons (\uparrow , \downarrow , \leftarrow , \rightarrow) to select an item or sub-item, and then press the SET button.

According to the selected item or sub-item, a selection list or a clip properties screen appears (see page 86).

To return to the previous state, push the MENU CANCEL/PRST/ESCAPE switch down to the ESCAPE side.

Notes

- When an S×S memory card is write protected, it is not possible to copy, delete, or divide clips, to change index pictures, or to add and delete OK marks and shot marks.
- Some items cannot be selected, depending on the state of the camcorder when the menu was displayed.

To hide the clip properties screen

Do one of the following.

Press the RESET/RETURN button: This returns to the THUMBNAIL menu.

Press the THUMBNAIL button: The camcorder enters E-E mode, and the camera picture appears.

Press the PLAY/PAUSE button: Playback from the selected clip starts.

Changing the Thumbnail Screen Type

To display OK clip thumbnails (HD mode only)

From among all clips stored on the currently selected S×S memory card, the OK clip thumbnail screen displays only clips which have been marked with an OK mark.

When the normal thumbnail screen is displayed, you can select THUMBNAIL >Filter Clips to switch to the OK clip thumbnail screen.

See “Adding and Deleting OK Marks (HD Mode Only)” (page 87) for information about how to add OK marks.

To display the all clips thumbnail screen

The all clips thumbnail screen displays thumbnails of all of the clips on the selected memory card, including both HD-mode and SD-mode clips. This is useful when you want to check whether the memory card contains clips in another mode.

You can switch to the all clips thumbnail screen by selecting THUMBNAIL >All Clip Thumbnail in the setup menu in the normal thumbnails screen.

Pressing the RESET/RETURN button returns you to the normal thumbnails screen, where you can perform playback and other clip operations.

Note

You cannot start playback from the all clips thumbnail screen.

Displaying Clip Properties

The clip properties screen appears when you select Clip Properties in the THUMBNAIL menu.

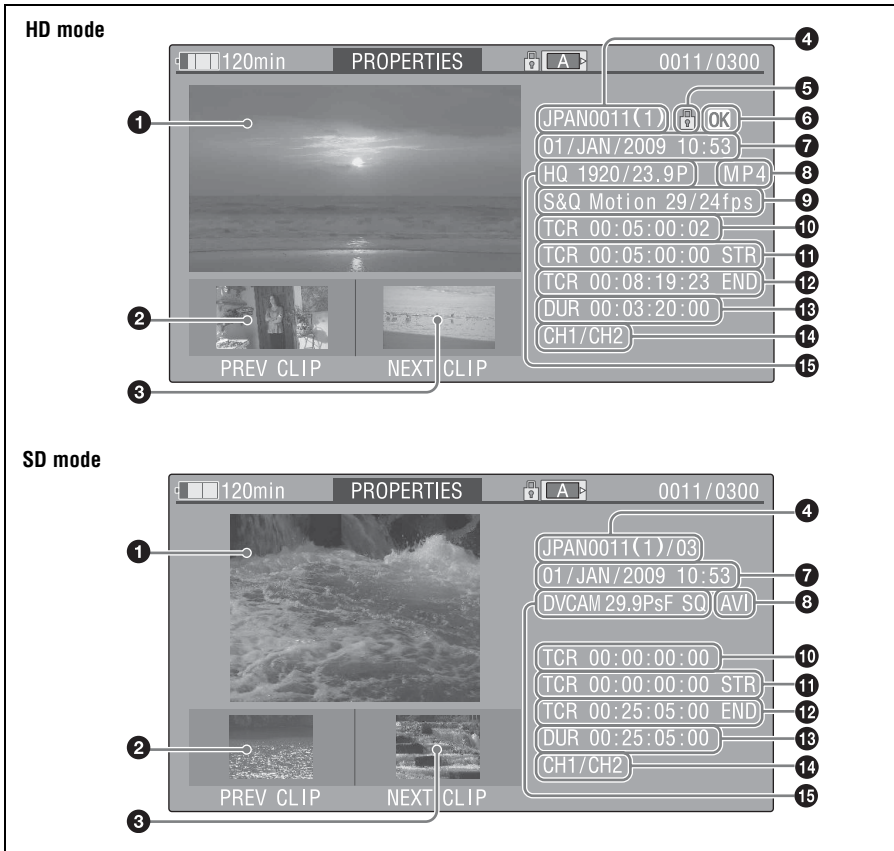

1 Image of the current clip

2 Image of the previous clip

Press the PREV button to display the properties of the previous clip.

3 Image of the next clip

Press the NEXT button to display the properties of the next clip.

4 Clip name

In SD mode, only for clips that have been divided because the file size was greater than 2 GB, the number of component clips appears after the clip name.

5 Lock mark (HD mode only)

This appears when the clip is marked with an OK mark and protected.

6 OK mark (HD mode only)

This appears only when an OK mark has been added.

7 Date and start time of recording

8 File format

The file format of the clip (MP4 or AVI) appears.

9 Special recording information (HD mode only)

This displays the mode of clips that have been recorded in a special mode (Slow & Quick Motion, Interval Rec, Frame Rec).

For Slow & Quick Motion clips, the frame rates are displayed to the right as [Recording frame rate/Playback frame rate].

10 Timecode of the displayed image

11 Timecode of the recording start point

12 Timecode of the recording end point

13 Duration

14 Recorded audio channels

15 Video format of recording

Adding and Deleting OK Marks (HD Mode Only)

You can add OK marks to clips. This makes it possible to display thumbnails of only the clips that you need by pressing the THUMBNAIL button.

Clips with OK marks cannot be deleted or divided. If you want to delete or divide such a clip, delete the OK mark first.

To add an OK mark

1 In the thumbnail screen, select THUMBNAIL >Add OK Mark.

The screen changes to the clip properties screen, and a confirmation message appears beneath the index picture.

2 Select [Execute], and press the MENU knob.

An OK mark is added to the selected clip.

To delete an OK mark

A Delete OK Mark item appears in the THUMBNAIL menu when you have selected a clip that has an OK mark.

1 In the thumbnail screen, select THUMBNAIL >Delete OK Mark.

The screen changes to the clip properties screen, and a confirmation message appears beneath the index picture.

2 Select [Execute], and press the MENU knob.

The OK mark is deleted from the selected clip.

Copying Clips

You can copy clips to other S×S memory cards. Clips are copied to destination S×S memory cards using the same names as the original clips.

Notes

- If a clip with the same name already exists at the copy destination S×S memory card, a one-digit number in parentheses is added to the original name. The number in parentheses is the smallest number that does not exist at the copy destination.

Examples:

ABCD0002→ABCD0002(1)

ABCD0002(1)→ABCD0002(2)

ABCD0005(3)→ABCD0005(4)

- If the parenthetical numbers (1) to (9) already exist at the copy destination, it is not possible to copy any more clips under that name. (A tenth clip cannot be copied.)
- A message appears if there is not enough free capacity at the copy destination S×S memory card. Exchange the card for one with more free capacity.

1 In the thumbnail screen, select the thumbnail of the clip to copy, and then select THUMBNAIL >Copy Clip.

The screen changes to the properties screen of that clip, and a confirmation message appears beneath the index picture.

2 Select [Execute], and press the MENU knob.

The copy starts.

During the copy, an execution message and progress bar are displayed.

When the copy finishes, the display returns to the thumbnail screen.

To cancel a copy operation

Press the RESET/RETURN button.

The copy is cancelled, and the display returns to the thumbnail screen.

To batch copy groups of clips

You can batch copy groups of clips from one S×S memory card to another S×S memory card.

When both HD-mode and SD-mode clips exist on the source S×S memory card, only clips in the currently selected mode are copied. This is a convenient way to extract clips in one of the modes.

1 In the thumbnail screen, select the thumbnails of the clips to copy and then select THUMBNAIL >Copy All Clips.

The confirmation message “Copy All Clips?” appears.

2 Select [Execute], and press the MENU knob.

The copy starts.

During the copy, the progress of the copy is displayed.

If you executed the copy in HD mode, only HD-mode clips are copied.

If you executed the copy in SD mode, only SD-mode clips are copied.

To cancel the copy operation

Press the RESET/RETURN button.

When the copy finishes

A completion message appears, and the THUMBNAIL menu screen appears again.

Deleting Clips

You can delete clips from S×S memory cards.

Note

HD clips with OK marks cannot be deleted.

If you want to delete such clips, first delete the OK marks (*see page 87*).

1 In the thumbnail screen, select the thumbnail of the clip to delete, and then select THUMBNAIL >Delete Clip.

The screen changes to the properties screen of that clip, and a confirmation message appears beneath the index picture.

2 Select [Execute], and press the MENU knob.

The clip is deleted.

In the thumbnail screen, the clips that followed the deleted clip move up one position.

To batch delete groups of clips

You can batch delete groups of clips from an S×S memory card.

Notes

- When both HD-mode and SD-mode clips exist on the S×S memory card, only clips in the currently selected mode are deleted.
- In HD mode, clips with OK marks are not deleted, even when a deletion is executed for a group of clips that includes them.

1 In the thumbnail screen, select the thumbnails of the clips to delete and then select THUMBNAIL >Delete All Clips.

The confirmation message “Delete All Clips?” appears.

2 Select [Execute], and press the MENU knob.

The deletion starts.

During the deletion, the progress of the deletion is displayed.

If you executed the deletion in HD mode, only HD-mode clips are deleted.

If you executed the deletion in SD mode, only SD-mode clips are deleted.

To cancel the deletion

Press the RESET/RETURN button.

When the deletion finishes

A completion message appears, and the THUMBNAIL menu screen appears again.

Displaying the Expand Thumbnail Screen

The expand thumbnail screen allows you to search inside clips by using thumbnails (*see page 83*), to change index pictures (*see page 90*), and to add and delete shot marks (*see page 90*).

To display the screen

In the thumbnail screen, select a thumbnail and press the EXPAND button (*see page 20*) or select THUMBNAIL >Thumbnail View >Forward Expansion.

An expand thumbnail screen for the selected clip appears.

Expand thumbnail screen in HD mode

In HD mode, the selected clip is divided into 12 equally-sized blocks, and a thumbnail of the first frame in each block is displayed.

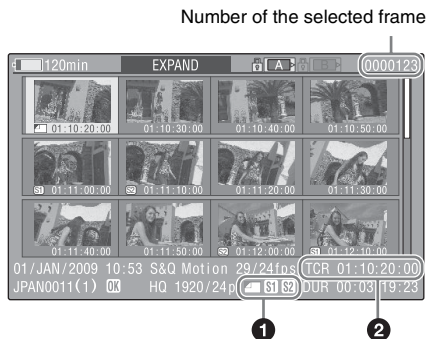



Clip properties are shown at the bottom of the screen.

Except for the items listed below, the information displayed here is the same as the information displayed in the normal thumbnail screen.

1 Frame information

This displays frame information using icons.

	Index picture
	Frame with Shot Mark1
	Frame with Shot Mark2

The same icons are also displayed beneath the thumbnails. However, when several icons could be displayed for the same frame, one icon is selected for display, in the order of priority Index picture > Shot Mark 1 > Shot Mark2.

2 Timecode

This displays the timecode of the selected frame in the expand thumbnail screen.

Expand thumbnail screen in SD mode

In SD mode, only in the case of clips that have been split into partial files because the file size was larger than 2 GB, a thumbnail of the first frame of each partial file is displayed.

Number of the selected frame

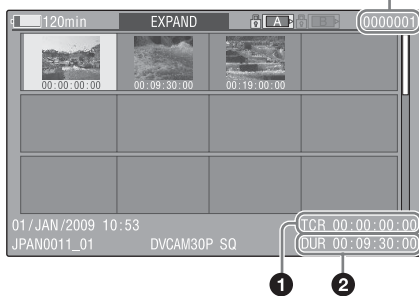

Clip properties are displayed at the bottom of the screen.

Except for the items listed below, the information displayed here is the same as the information displayed in the normal thumbnail screen.

1 Timecode

This is the timecode of the selected partial file.

2 Duration

This is the duration of the selected partial file.

To increase the number of divisions

When you press the EXPAND button, or select THUMBNAIL >Thumbnail View >Forward Expansion, the divided clip or file is further divided into 12 equally-sized blocks (a clip or file that has been divided into 12 is further divided into 12, for $12 \times 12 = 144$ divisions). You can repeat the same operation to increase the number of division.

To return to the previous division level

Press the EXPAND button with the SHIFT button held down, or select THUMBNAIL >Thumbnail View >Back Expansion. The expand thumbnail screen returns to the previous division level.

Displaying the Shot Mark Thumbnail Screen (HD Mode Only)

In the shot mark thumbnail screen (shown only in HD mode), you can search for shot marks in clips (see page 83), change index pictures (see page 90), and add and delete shot marks (see page 90).

- 1 In the thumbnail screen, select the thumbnail of a clip, and press the **ESSENCE MARK** button (see page 22) or select **THUMBNAIL >Thumbnail View >Essence Mark Thumbnail**.
- 2 The shot mark thumbnail screen appears, and a selection list is displayed.
- 3 Select **Shot Mark, Shot Mark1, or Shot Mark2**.
Shot Mark1: Display only frames marked with Shot Mark1 marks.
Shot Mark2: Display only frames marked with Shot Mark2 marks.
Shot Mark: Display frames marked with either Shot Mark1 or Shot Mark2 marks.

Example shot mark thumbnail screen (with Shot Mark selected)



The properties of the clip appear at the bottom of the screen.

Except for the following item, the information displayed here is the same as the information displayed in the expand thumbnail screen.

1 Timecode

This is the timecode of the selected frame in the shot mark thumbnail screen.

Adding and Deleting Shot Marks (HD Mode Only)

In the shot mark thumbnail screen (see page 89) or the expand thumbnail screen (see page 88), you can add thumbnails to any frame of clips recorded in HD mode, and delete recorded shot marks.

To add shot marks

- 1 Select the frame where you want to add a shot mark, and then select **THUMBNAIL > Set Shot Mark > Add Shot Mark1 (or Add Shot Mark2)**. The properties screen of the selected frame appears, and a confirmation message appears below the image.
- 2 Select **[Execute]**, and press the **MENU** knob.

To delete shot marks

- 1 Select the frame where you want to delete a shot mark, and then select **THUMBNAIL > Set Shot Mark > Delete Shot Mark1 (or Delete Shot Mark2)**. The properties screen of the selected frame appears, and a confirmation message appears below the image.
- 2 Select **[Execute]**, and press the **MENU** knob.

Changing Clip Index Pictures (HD Mode Only)

In the expand thumbnail screen (see page 88) or the shot mark thumbnail screen (see page 89), you can set the selected frame as the clip index picture in HD mode.

- 1 Select the thumbnail of the frame that you want to use as the index picture, and then select **THUMBNAIL >Set Index Picture**. The properties screen of the selected frame appears, and a confirmation message appears below the image.
- 2 Select **[Execute]**, and press the **MENU** knob.

Note

Even if you set the index picture to a frame that is not the first frame of a clip, playback of that clip from a thumbnail screen always begins at the first frame.

Dividing Clips (HD Mode Only)

In the expand thumbnail screen (*see page 88*) and the shot mark thumbnail screen (*see page 89*), HD-mode clips can be divided into two clips at the selected frame.

1 Select the thumbnail of the frame where you want to divide the clip, and then select THUMBNAIL >Divide Clip.

The properties screen of the selected frame appears, and a confirmation message appears below the image.

2 Select [Execute], and press the MENU knob.

The clip is divided at the selected frame, and two clips with different names are created.

The first four characters of the clip name are taken from the name of the original clips, and the last four characters are new serial numbers.

Example: When the name of a newly recorded clip would be EFGH0100, and a clip named ABCD0002 is divided, the names of the two newly created clips are ABCD0100 and ABCD0101.

Note

When there is not enough remaining capacity on the S×S memory cards to store the divided clips, a message appears to inform you that there is not enough capacity.

Setup Menu Organization and Levels

On this camcorder, settings for shooting and playback are made in the setup menu, which appears in the viewfinder. The setup menu can also be displayed on an external video monitor (*see page 140*).

Setup Menu Organization

The setup menu consists of the following menus.

Op: OPERATION menu

Settings related to shooting, except settings related to picture quality (*see page 96*)

Pa: PAINT menu

Settings related to picture quality (*see page 109*)

Th: THUMBNAIL menu

Settings related to clip thumbnails (*see page 84*)

Note

The THUMBNAIL menu is used only when a thumbnail screen (*see page 80*) is displayed. It is disabled when no thumbnail screen is displayed.

Ma: MAINTENANCE menu

Settings related to audio and timecode (*see page 115*)

Fi: FILE menu

Settings related to file operations (*see page 127*)

Setup Menu Levels

See “THUMBNAIL Menu Configuration” (page 84) for the organization of the THUMBNAIL menu.

OPERATION Menu (*see page 96*)

OPERATION

- Format
- Format Media
- Input/Output
- Super Impose
- Rec Function
- Assignable SW
- VF Setting
- Marker
- Gain Switch
- TLCS
- Zebra
- Display On/Off
- Auto Iris
- White Setting
- Offset White
- Shutter Select
- Time Zone
- Clip

PAINT Menu (see page 109)

PAINT

- Switch Status
- White
- Black
- Flare
- Gamma
- Black Gamma
- Knee
- White Clip
- Detail(HD Mode)
- Detail(SD Mode)
- Aperture
- Skin Detail
- Matrix
- Multi Matrix
- V Modulation
- Low Key Saturation
- Noise Suppress

FILE Menu (see page 127)

FILE

- All
- Scene
- Reference
- Lens

MAINTENANCE Menu (see page 115)

MAINTENANCE

- White Shading
- Black Shading
- Battery
- Audio
- WRR Setting
- Timecode
- Essence Mark
- Camera Config
- Preset White
- White Filter
- DCC Adjust
- Auto Iris2
- Flicker Reduce
- Genlock
- ND Comp
- Lens
- Auto Shading
- Trigger Mode
- Clock set
- Language
- Hours Meter
- Version



Basic Setup Menu Operations

To display the setup menu

Set the MENU ON/OFF switch to ON, or press the MENU button.

The camcorder enters menu mode and the menu list appears on the screen.

A cursor appears over the first two characters of the most recently used menu, and the corresponding menu item selection area appears to the right.

Example: When the cursor is positioned at the OPERATION menu

Menu list

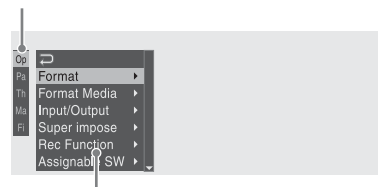

Menu item selection area

Note

The setup menu cannot be used when the camcorder is in focus magnification mode. Exit focus magnification mode by pressing the assignable switch to which the Focus Mag function has been assigned.

To make menu settings

1 Turn the MENU knob, or press the \uparrow or \downarrow button, to move the cursor to the item that you want to set.

A list of selectable menu items appears in the menu item selection area to the right of the icon.

2 Press the MENU knob or the SET button.

The cursor moves to the menu item selection area.

You can also move the cursor to the menu item selection area by pressing the \Rightarrow button.

- The menu item selection area displays a maximum of seven lines. You can scroll through menus with more than seven lines by moving the cursor up and down. Triangles appear at the upper right and lower right of the menu item selection area to indicate that a menu is scrollable.

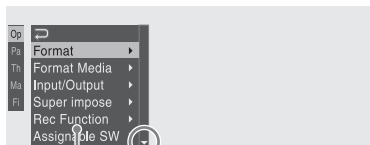

Appears when more menu items are available below the last line. (\blacktriangle appears when more menu items are available above the first line.)

Menu item selection area

- \blacktriangleright appears to the right when more detailed sub-items are available.
- Settings appear to the right when a menu item has no sub-items.
- You can select \curvearrowright to return to the previous level.

3 Turn the MENU knob, or press the \uparrow or \downarrow button, to move the cursor to the item that you want to set, and then confirm by pressing the MENU knob or the SET button.

The sub-items area appears to the right of the menu item selection area, and the cursor moves to the first sub-item.

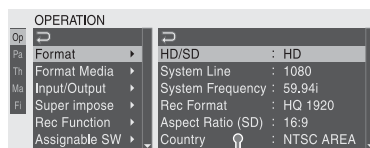

Sub-items area

- Displays sub-items and their current settings
- To return to the previous level, select \curvearrowright , press the \Leftarrow button, or push the MENU CANCEL/PRST/ESCAPE switch down to the ESCAPE side.

- 4 Turn the MENU knob, or press the \uparrow or \downarrow button, to move the cursor to the sub-item that you want to set, and then confirm the selection by pressing the MENU knob or the SET button.**

The settings of the selected sub-item appear, and the cursor moves to the currently selected value.

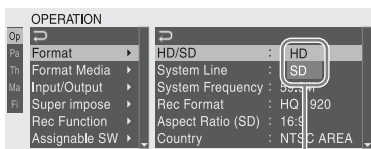

Settings area

- The settings area displays a maximum of seven lines. You can scroll through menus with more than seven sub-items by moving the cursor up and down. Triangles appear at the upper right and lower right of the settings area to indicate that a sub-item menu is scrollable.
 - For sub-items with a large settings range (for example, -99 to +99), the settings area is not displayed. Instead, the sub-item name is highlighted to indicate that the sub-item can be set.
- 5 Turn the MENU knob, or press the \uparrow or \downarrow button, to select the value to set, and then confirm by pressing the MENU knob or the SET button.**
- The setting is changed, and the display is updated to show the new setting.
- If you select [Execute] for an executable item, the corresponding function is executed.

Items that require confirmation before execution

In step 3, the menu disappears and a confirmation message appears if you select an item that requires confirmation before execution. Follow the instructions in the message to execute or cancel the operation.

To enter text

Some items, such as time data or file names, must be set by entering text. When you select one of these items, the text entry area is highlighted, with “SET” displayed to the right.

- 1 Turn the MENU knob, or press the \uparrow or \downarrow button, to select a character, and then confirm by pressing the MENU knob or the SET button.**

The cursor moves to the next position.

To return to the previous position, push the MENU CANCEL/PRST/ESCAPE switch down to the ESCAPE side.

- 2 Select characters for all positions up to the last.**

The cursor moves to “SET”.

- 3 Press the MENU knob or the SET button.**

This confirms the setting.

To cancel the setting change

Push the MENU CANCEL/PRST/ESCAPE switch down to the ESCAPE side.

To reset a setting to the initial value

- 1 Before a setting is changed or after a setting change is cancelled, push the MENU CANCEL/PRST/ESCAPE switch up to the CANCEL/PRST side.**

- 2 When the message to confirm whether the current setting is reset to the initial value, push the MENU CANCEL/PRST/ESCAPE switch up to the CANCEL/PRST side again.**

The current setting is reset to the initial value.

To exit the menu

Set the MENU ON/OFF switch to OFF or press the MENU button.

The normal camera picture reappears.

Menu List

Settings in bold are the factory default values.

OPERATION Menu

OPERATION			
Menu items	Sub-item	Settings	Description
Format Specifies the camcorder's operating mode and recording format.	HD/SD	HD/SD	Switches between HD or SD as the operating mode (execute by selecting Execute). Note When the optional CBK-DV01 is not installed, [SD] cannot be selected. (SD recording is not allowed.)
	HD System Line	1080/720	When the operating mode is HD, sets the number of system lines to 1080 or 720 (execute by selecting Execute).
	System Frequency	The available settings vary depending on the settings in HD/SD, HD System Line, and Country. 59.94i/29.97P/23.98P	Selects the system frequency (execute by selecting Execute). When the HD/SD setting is [HD], the HD System Line setting is [1080], and the Country setting is other than [PAL Area].
		59.94P/29.97P/23.98P	When the HD/SD setting is [HD], the HD System Line setting is [720], and the Country setting is other than [PAL Area].
		59.94i/29.97P	When the HD/SD setting is [SD], and the Country setting is other than [PAL Area].
		50i/25P	<ul style="list-style-type: none"> When the HD/SD setting is [HD], the HD System Line setting is [1080], and the Country setting is [PAL Area]. When the HD/SD setting is [SD], and the Country setting is [PAL Area].
		50P/25P	When the HD/SD setting is [HD], the HD System Line setting is [720], and the Country setting is [PAL Area].

OPERATION			
Menu items	Sub-item	Settings	Description
Format Specifies the camcorder's operating mode and recording format.	Rec Format	The available settings vary depending on the settings in HD/SD, HD System Line, and System Frequency.	Selects the recording format (execute by selecting Execute).
		HQ 1920/HQ 1440	When the HD/SD setting is [HD], the HD System Line setting is [1080], and the System Frequency setting is [29.97P] or [25P].
		HQ 1920/HQ 1440/SP 1440	When the HD/SD setting is [HD], the HD System Line setting is [1080], and the System Frequency setting is other than [29.97P] and [25P].
		HQ 1280	When the HD/SD setting is [HD], and the HD System Line setting is [720].
		DVCAM	When the HD/SD setting is [SD].
	Aspect Ratio(SD)	16:9/4:3	Selects the aspect ratio when SD mode (recording format: DVCAM ^{a)} is selected (execute by selecting Execute).
Format Media Executes a media format.	Country	NTSC Area/NTSC(J) Area/PAL Area	Selects the area of use (execute by selecting Execute).
	Media(A)	Execute/Cancel	Initializes the S×S memory card in slot A (execute by selecting Execute).
	Media(B)	Execute/Cancel	Initializes the S×S memory card in slot B (execute by selecting Execute).

OPERATION			
Menu items	Sub-item	Settings	Description
Input/Output Makes settings related to I/O signals.	Output& i.LINK	HD&HDV/SD&HDV/SD&DV/480P (576P)	Selects the signals output from the video connectors and the i.LINK (HDV/DV) connector. <ul style="list-style-type: none"> • When the HD/SD setting is SD, “SD&DV” is selected. • On 480P576P, “480P” can be selected when the Country setting is other than “PAL Area”, and “576P” can be selected when the Country setting is “PAL Area”.
	23.98P Output	PsF/Pull Down	When the video format is HQ 1920/23.98P or HQ 1440/23.98P, selects whether to use progressive output (PsF) or pulldown output (Pull Down).
	Source Select	Camera/i.LINK	Selects whether to use the video camera picture (Camera) or the signal input from the i.LINK (HDV/DV) connector (i.LINK) as the video input source.
	i.LINK I/O	Enable/Disable	Selects whether to enable or disable input and output of signals via the i.LINK (HDV/DV) connector.
	SDI Output	On/Off	Turns on or off the output of signals from the HD/SD SDI OUT connector.
	HDMI Output	On/Off	Turns on or off the output of signals from the HDMI connector.
	SDI/HDMI Out Super	On/Off	Turns on or off the superimposition of text information on the output of the HD/SD SDI OUT and HDMI connectors.
	Video Out Super	On/Off	Turns on or off the superimposition of text information on the output of the VIDEO OUT connector.

OPERATION			
Menu items	Sub-item	Settings	Description
Input/Output Makes settings related to I/O signals.	Down Converter	Crop/Letter/ Squeeze	Selects the signal conversion mode for output of SD signals. Crop: Crop the edges of the 16:9 picture and output as a 4:3 picture. Letter: Mask the top and bottom of the 4:3 picture and display in the center of the screen as a 16:9 picture. Squeeze: Squeeze the 16:9 picture horizontally and output as a 4:3 picture.
	Wide ID	Through /AUTO	Selects whether to add wide picture information to the SD output signal. Through: Output without adding wide picture information. AUTO: Add and output wide picture information when the Down Converter setting is Squeeze.
Super Impose Makes settings related to superimposed text and markers.	Super(VF Display)	On /Off	When the setting of Input/Output >SDI/HDMI Out Super or Video Out Super is On, superimpose text information on the output from the HD/SD SDI OUT connector, HDMI connector, and VIDEO OUT connector, as specified (On or Off) for each item.
	Super(Menu)	On /Off	
	Super(Timecode)	On/ Off	
	Super(Marker)	On/ Off	

OPERATION			
Menu items	Sub-item	Settings	Description
Rec Function Makes settings related to special recording modes.	Slow & Quick	On/Off	Turns the Slow & Quick Motion function on or off. (When this is set to On, the Picture Cache Rec, Interval Rec, and Frame Rec sub-items are set to Off.)
	Frame Rate	The available settings vary depending on the Format >HD System Line setting.	When the Slow & Quick setting is On, sets the frame rate for Slow & Quick Motion shooting.
		When Format >Country is set to other than [PAL Area]: 1 to 30 When Format >Country is set to [PAL Area]: 1 to 25 to 30	When the HD System Line setting is 1080.
		When Format >Country is set to other than [PAL Area]: 1 to 30 to 60 When Format >Country is set to [PAL Area]: 1 to 25 to 60	When the HD System Line setting is 720.
	Picture Cache Rec	On/Off	Turns the picture cache function on or off. (When this is set to On, the Slow & Quick, Interval Rec, Frame Rec sub-items are set to Off.)
	P. Cache Rec Time	0-2sec/2-4sec/4-6sec/6-8sec/8-10sec/10-12sec/12-14sec/13-15sec	When the Picture Cache Rec setting is On, set the picture cache time.
	Interval Rec	On/Off	Turns the Interval Rec function on or off. (When this is set to On, the Slow & Quick, Picture Cache Rec, and Frame Rec sub-items are set to Off.)
	Frame Rec	On/Off	Turns the Frame Rec function on or off. (When this is set to On, the Slow & Quick, Picture Cache Rec, and Interval Rec sub-items are set to Off.)
	Number of Frames	The available settings vary depending on the settings in Format >HD System Line and Format >System Frequency.	When Interval Rec or Frame Rec is set to On, specifies the number of frames to shoot in one Interval Rec or Frame Rec take.
2frame/6frame/12frame		When the HD System Line setting is 720, and the System Frequency setting is 59.94P or 50P.	
1frame/3frame/6frame/9frame		When the HD System Line setting is other than 720, or the System Frequency setting is other than 59.94P or 50P.	

OPERATION			
Menu items	Sub-item	Settings	Description
Rec Function Makes settings related to special recording modes.	Interval Time	1/2/3/4/5/6/7/8/9/10/15/ 20/30/40/50 (sec) 1/2/3/4/5/6/7/8/9/10/15/ 20/30/40/50 (min) 1/2/3/ 4/6/12/24 (hour)	When the Interval Rec setting is On, sets the interval for Interval Rec shooting.
	Pre-Lighting	Off/2sec/5sec/10sec	If you want the video light to be turned on before Interval Rec shooting, select a number of seconds before the start of shooting. If you do not want it to be turned on, select Off.
Assignable SW Assigns functions to assignable switches. <i>See "Assigning Functions to Assignable Switches" (page 131) for more information about assigning functions.</i>	<0>	<i>See page 131.</i>	Assigns function to ASSIGN. 0 switch.
	<1>		Assigns function to ASSIGN. 1 switch.
	<2>		Assigns function to ASSIGN. 2 switch.
	<3>		Assigns function to ASSIGN. 3 switch.
	<4>		Assigns function to ASSIGNABLE 4 switch.
	<5>		Assigns function to ASSIGNABLE 5 switch.
	RET		Assigns function to RET button on the lens.
	C. Temp		Assigns function to COLOR TEMP. button.
	Zoom Speed	0 to 20 to 99	

OPERATION			
Menu items	Sub-item	Settings	Description
VF Setting Makes settings related to the viewfinder screen.	Color	-99 to ± 0 to +99	Adjusts the density of the colors displayed in the viewfinder screen.
	Mode	Color/B&W	Selects Color or B&W as the display mode of the viewfinder screen. (Even when B&W is selected, some indications are always displayed in color. Examples include tally indications, thumbnails, and the skin gate area.)
	Peaking Type	Normal/Color/Both	Selects the peaking type. Normal: Normal peaking Color: Color peaking Both: Both
	Peaking Frequency	Normal/High	Selects Normal or High as the peaking frequency.
	Peaking Color	White/Red/Yellow/Blue	When the Peaking Type setting is Color, selects the peaking color from among White, Red, Yellow, and Blue.
	Peaking Level	Low/Mid/High	When the Peaking Type setting is Both, selects the color peaking level from among Low, Mid, and High.
	DXF Rec Tally	Upper/Both	When a separately sold viewfinder is installed, specified whether to light the tally indicator on the upper side only (Upper), or on both the upper and lower sides (Both).

OPERATION			
Menu items	Sub-item	Settings	Description
Marker Makes settings related to marker display in the viewfinder screen.	Setting	On/Off	Turns all markers on or off.
	Center Marker	1/2/3/4/ Off	When the center marker is displayed, selects the type. Select Off if you do not want to display the marker.
	Center H Position	-40 to 0 to 40	Specifies the horizontal position of the center marker.
	Center V Position	-40 to 0 to 40	Specifies the vertical position of the center marker.
	Safety Zone	On/Off	Turns the safety zone display on or off.
	Safety Area	80%/90%/92.5%/95%	Selects the safety zone range.
	Aspect Marker	Line/Mask/ Off	When an aspect marker is to be displayed, selects the display method. Select Off if you do not want to display the marker. Line: Show as white lines. Mask: Display by lowering the video signal level of areas outside the marker range.
	Aspect Select	15:9/14:9/13:9/4:3/ 1.66:1/1.85:1/2.35:1/ 2.4:1	Selects the aspect ratio of the marker.
	Aspect Mask	0% to 30% to 90% (10% step)	When the Aspect Marker setting is Mask, specifies the video signal level of areas outside the marker range as a percentage value relative to the video signal level of areas inside the marker range.
	User Box	On/Off	Turns the box cursor display on or off.
	User Box Width	40 to 500 to 999	Specifies the box cursor width (distance from the center to the left and right edges).
	User Box Height	70 to 500 to 999	Specifies the box cursor height (distance from the center to the top and bottom edges).
	User Box H Position	-479 to 0 to 479	Specifies the horizontal position of the box cursor center.
	User Box V Position	-464 to 0 to 464	Specifies the vertical position of the box cursor center.
Guide Frame	On/Off	Turns display of the guide frame on or off.	

OPERATION				
Menu items	Sub-item	Settings	Description	
Gain Switch Makes settings related to the GAIN switch.	Gain Low	-3dB/ 0dB /3dB/6dB/9dB/ 12dB/18dB/24dB/30dB/ 36dB/42dB	Specifies the gain value for the L position of the GAIN switch.	
	Gain Mid	-3dB/0dB/3dB/ 6dB /9dB/ 12dB/18dB/24dB/30dB/ 36dB/42dB	Specifies the gain value for the M position of the GAIN switch.	
	Gain High	-3dB/0dB/3dB/6dB/9dB/ 12dB /18dB/24dB/30dB/ 36dB/42dB	Specifies the gain value for the H position of the GAIN switch.	
	Gain Turbo	-3dB/0dB/3dB/6dB/9dB/ 12dB/18dB/24dB/30dB/ 36dB/ 42dB	Specifies the gain value for the Turbo Gain function, which can be assigned to an assignable switch.	
	Shockless Gain	On/ Off	Turns shockless gain (a function that switches smoothly when the gain is switched) on or off.	
TLCS Makes settings related to total level control.	Mode	Backlight/ Standard / Spotlight	Selects the auto iris mode used when the TLCS system is activated. Backlight: Backlight mode (lessens the blackout of the main subject that occurs under backlit conditions) Standard: Standard mode Spotlight: Spotlight mode (lessens the whiteout of the main subject that occurs under a spotlight)	
	Speed	-99 to ±0 to +99	Specifies the control speed (speed of reaction to changes in the video) used when the TLCS system is activated. (Larger values specify quicker reaction times.)	
	AGC	On/ Off	Turns the AGC (auto gain control) function on or off.	
	AGC Limit	3dB/6dB/9dB/ 12dB / 18dB	Specifies the maximum gain used when AGC is on.	
	AGC Point	F5.6/F4/ F2.8	Specifies the F value where control by auto iris switches to control by AGC, used when AGC is on.	
	Auto Shutter	On/ Off	Turns the auto shutter function on or off.	
	Auto Shutter Limit	1/100 / 1/150 / 1/200 / 1/250	Selects the maximum shutter speed used when auto shutter is on.	
	Auto Shutter Point	F5.6/F8/F11/ F16	Specifies the F value where control by auto shutter switches to control by auto shutter, used when auto shutter is on.	
	Zebra Makes settings related to zebra displays.	Zebra Select	1/2 /BOTH	Selects the zebra pattern type (Zebra1, Zebra2, Both).
		Zebra1 Level	50% to 70% to 107%	Specifies the Zebra1 display level.
Zebra1 Aperture Level		1 to 10% to 20%	Specifies the Zebra1 aperture level.	
Zebra2 Level		52% to 100% to 109%	Specifies the Zebra2 display level.	

OPERATION			
Menu items	Sub-item	Settings	Description
Display On/Off Selects the items to display in the viewfinder screen.	Video Level Warnings	On/Off	Turns the warnings that appear when the video level is too bright or too dark on or off.
	Brightness Display	On/Off	Turns the numerical indication of the video brightness on or off.
	Histogram Display	On/Off	Turns the histogram display of video signal levels on or off (in HD mode only).
	Lens Info	Off/Meter/Feet	Selects meters or feet as the unit for display of the depth of field. Select Off if you do not want to display the depth of field.
	Focus Position	On/Off	Turns the indication of the lens focus position on or off.
	Zoom Position	On/Off	Turns the indication of the lens zoom position on or off.
	Audio Level Meter	On/Off	Turns the display of the audio level meters on or off.
	Timecode	On/Off	Turns the display of time data (timecode, user bits, counter, duration) on or off.
	Battery Remain	On/Off	Turns the indications of the remaining battery time and input voltage on or off.
	Media Remain	On/Off	Turns the indication of the remaining media capacity on or off.
	TLCS Mode	On/Off	Turns the indication of the TLCS operating mode on or off.
	Focus Mode	On/Off	Turns the indication of the focus operating mode on or off.
	White Balance Mode	On/Off	Turns the indication of the white balance mode on or off.
	Filter Position	On/Off	Turns the indication of the ND filter setting on or off.
	Iris Position	On/Off	Turns the indication of the iris position on or off.
	Gain Setting	On/Off	Turns the indication of the gain setting on or off.
	Shutter Setting	On/Off	Turns the indications of the shutter mode and shutter speed on or off.
Color Temp	On/Off	Turns the indication of the color temperature on or off.	
Video Format	On/Off	Turns the indication of the video format on or off.	

OPERATION			
Menu items	Sub-item	Settings	Description
Display On/Off Selects the items to display in the viewfinder screen.	System Line	On/Off	Turns the indication of the system lines on or off.
	Rec Mode	On/Off	Turns the indication of special recording modes (S&Q, Interval, Frame Rec, Picture Cache Rec) on or off.
	Extender	On/Off	Turns the lens extender indication on or off.
	WRR RF Level	On/Off	Turns the indication of the digital wireless receiver reception level on or off.
	Clip Number(PB)	On/Off	Turns the indication of clip information on or off.
Auto Iris Makes settings related to auto iris.	Iris Override	On/Off	Turns iris override (a setting that opens or closes the iris more than normal) on or off.
	Iris Speed	-99 to ± 0 to +99	Specifies the iris control speed (speed of reaction to changes in the video). (Larger values specify quicker reaction times.)
	Clip High light	On/Off	Turns on or off the function that disregards highlights and forces a flatter reaction to high luminance.
	Iris Window	1/2/3/4/5/6/Var	Selects the auto iris detection window type. Var: Variable
	Iris Window Indication	On/Off	Turns the indication of the auto iris detection window frame on or off.

OPERATION			
Menu items	Sub-item	Settings	Description
White Setting Makes settings related to auto white balance adjustments.	White Switch	Memory/ATW	Specifies the operating mode selected by the B position of the WHITE BAL switch. Memory: Auto white balance ATW: Auto tracing white balance
	Shockless White	Off/1/2/3	Specifies the reaction speed when the WHITE BAL switch setting is changed. Off is an instant reaction, and 1 is faster than 2 or 3.
	ATW Speed	1/2/3/4/5	Specifies the reaction speed when the White Switch setting is ATW. 1 is the fastest reaction.
	AWB Fixed Area	On/Off	Specifies whether auto white balance is executed at the center of the screen. On: Execute in an area corresponding to 25% of the height and width of the screen. Off: Execute in an area corresponding to 70% of the height and width of the screen.
	Filter White Memory	On/Off	Specifies whether to allocate a white balance memory area for each FILTER knob position. On: Allocation a white balance memory area for each FILTER knob position. Off: Use A/B memory regardless of the filter position.

OPERATION			
Menu items	Sub-item	Settings	Description
Offset White Makes settings related to white balance offset values.	Offset White <A>	On/Off	Specifies whether to add (On) or not to add (Off) an offset value to the white balance value in memory A.
	Warm Cool <A>	Approximate color temperature	When the setting of Offset White<A> is On, specifies (as a color temperature) the offset to add to the white balance value in memory A. (Note that the error range becomes larger for higher offset color temperatures. Adjust while viewing the actual video.)
	Warm Cool Balance<A>	-99 to ± 0 to +99	Specifies a more precise color temperature, for use when satisfactory video cannot be obtained with the Warm Cool <A> setting.
	Offset White 	On/Off	When this is set to On, the offset adjusted set with this item is added to the white balance of channel B.
	Warm Cool 	Approximate color temperature	When the setting of Offset White is On, specifies (as a color temperature) the offset to add to the white balance value in memory B. (Note that the error range becomes larger for higher offset color temperatures. Adjust while viewing the actual video.)
	Warm Cool Balance	-99 to ± 0 to +99	Specifies a more precise color temperature, for use when satisfactory video cannot be obtained with the Warm Cool setting.
Shutter Select Makes settings related to shutter speed selection.	Shutter Select	Second/Degree	Specifies the unit used to select shutter speeds. Second: Select in units of seconds. Degree: Select in units of degrees.
Time Zone Specifies the time zone.	Zone	-12:00 to +0:00 to +14:00 (in steps of 30 minutes)	Specifies a difference from UTC (Greenwich Mean Time) in units of 30 minutes.
Clip Make settings for clip name or clip management.	Title Prefix	Text input Titles can contain upper- and lowercase alphanumeric characters (a to z, A to Z, 0 to 9), hyphens (-), and underscores (_).	Specifies the title part (four alphanumeric characters) of clip titles.
	Number Set	0001 to 9999	Specifies the initial value of the numeric part (four digits) of clip names.
	Update	Media<A>/Media	Updates the management files on the media in the selected slot (execute by selecting Execute).

a) When the optional CBK-DV01 is installed

PAINT Menu

PAINT			
Menu items	Sub-item	Settings	Description
Switch Status Turns various signal correction functions and a test signal on or off.	Gamma	On/Off	Turns gamma correction on or off.
	Black Gamma	On/Off	Turns black gamma correction on or off.
	Matrix	On/Off	Turns linear matrix correction and user matrix correction on or off.
	Knee	On/Off	Turns knee correction on or off.
	White Clip	On/Off	Turns white clip correction on or off.
	Detail	On/Off	Turns detail correction on or off.
	Aperture	On/Off	Turns aperture correction on or off.
	Flare	On/Off	Turns flare correction on or off.
	Test Saw	On/Off	Turns the test saw signal on or off.
	White Sets the color temperature, and performs manual white balance adjustment.	Color Temp <A>	1500K to 3200K to 5000K
Color Temp BAL <A>		-99 to ±0 to +99	Specifies the white balance gain values saved in memory A (linked R gain and B gain).
R Gain <A>		-99 to ±0 to +99	Specifies the white balance R gain value saved in memory A.
B Gain <A>		-99 to ±0 to +99	Specifies the white balance B gain value saved in memory A.
Color Temp 		1500K to 3200K to 5000K	Displays the white balance color temperature saved in memory B.
Color Temp BAL 		-99 to ±0 to +99	Specifies the white balance gain values saved in memory B (linked R gain and B gain).
R Gain 		-99 to ±0 to +99	Specifies the white balance R gain value saved in memory B.
B Gain 		-99 to ±0 to +99	Specifies the white balance B gain value saved in memory B.
Black Specifies the black level (level of the unilluminated parts of the video). You can achieve a desired look by adjusting the black level for deeper or shallower blacks.	Master Black	-99 to ±0 to +99	Specifies the master black level.
	R Black	-99 to ±0 to +99	Specifies the R black level.
	B Black	-99 to ±0 to +99	Specifies the B black level.

PAINT			
Menu items	Sub-item	Settings	Description
Flare Makes settings related to flare. Flare is light generated from a bright image region that spreads broadly across the image, adding light to dark regions and reducing contrast. It is caused by reflection inside the lens system.	Flare	On/Off	Turns flare correction on or off.
	Master Flare	-99 to ±0 to +99	Sets the master flare correction level.
	R Flare	-99 to ±0 to +99	Sets the R flare correction level.
	G Flare	-99 to ±0 to +99	Sets the G flare correction level.
	B Flare	-99 to ±0 to +99	Sets the B flare correction level.
Gamma Makes settings related to gamma. Gamma correction allows you to significantly alter the impression made by the video by adjusting the contrast.	Gamma	On/Off	Turns gamma correction on or off.
	Step Gamma	0.35 to 0.45 to 0.90 (0.05 step)	Specifies a gamma correction value in steps of 0.05
	Master Gamma	-99 to ±0 to +99	Specifies the master gamma level.
	R Gamma	-99 to ±0 to +99	Specifies the R gamma level.
	G Gamma	-99 to ±0 to +99	Specifies the G gamma level.
	B Gamma	-99 to ±0 to +99	Specifies the B gamma level.
	Gamma Select	The available settings vary depending on the setting in Gamma Category (see "Description").	Select the gamma table to use in gamma correction. When Gamma Category is STD: 1 DVW: DVW camcorder equivalent 2 ×4.5: ×4.5 gain 3 ×3.5: ×3.5 gain 4 240M: SMPTE-240M equivalent 5 R709: ITU-R709 equivalent (default setting) 6 ×5.0: ×5.0 gain When Gamma Category is HG: 1 3250: Condense 325% video input to 100% video output 2 4600: Condense 460% video input to 100% video output 3 3259: Condense 325% video input to 109% video output 4 4609: Condense 460% video input to 109% video output (default setting)
	Gamma Category	STD/HG	Selects use of standard gamma (STD) or HyperGamma (HG).
Black Gamma Makes settings related to black gamma correction. Black gamma correction allows you to reproduce gradations and color nuances in black or near-black (dark) parts of the picture.	Black Gamma	On/Off	Turns black gamma correction on or off.
	Gamma Level	-99 to ±0 to +99	Specifies the master black gamma level.
	Range	Low/L.Mid/H.Mid/ High	Selects the black gamma correction effective range. LOW: 0 to 3.6% L.MID: 0 to 7.2% H.MID: 0 to 14.4% HIGH: 0 to 28.8%

PAINT			
Menu items	Sub-item	Settings	Description
Knee Makes settings related to knee correction. Knee correction is processing that prevents washout by compressing the bright parts of the video according to an upper limit for the dynamic range of the recorded and output picture. The signal level where knee processing begins is called the “knee point”, and the slope of knee compression is called the “knee slope”.	Knee	On/Off	Turns knee correction on or off.
	Knee Point	50.0% to 95.0% to 109.0%	Specifies the knee point.
	Knee Slope	-99 to ±0 to +99	Specifies the knee slope.
	Knee Saturation	On/Off	Turns the knee saturation function on or off.
	Knee Saturation Level	-99 to ±0 to +99	Specifies the knee saturation level.
White Clip Makes settings related to white clipping adjustments. White clipping is processing that limits the maximum level of video output signals. The maximum video signal output value is called the “white clip level”.	White Clip	On/Off	Turns white clipping adjustment on or off.
	Level	NTSC Area is selected for Country 90.0% to 108.0% to 109.0% PAL Area is selected for Country 90.0% to 105.0% to 109.0%	Specifies the white clip level.

PAINT			
Menu items	Sub-item	Settings	Description
Detail(HD Mode)/ Detail(SD Mode) Makes settings related to details adjustments in HD mode and SD mode. Detail adjustment is processing that improves the clarity of the video by adding detail signals to the edges of the subject.	Detail	On/Off	Turns detail adjustment on or off.
	Level	-99 to ±0 to +99	Specifies the detail level.
	H/V Ratio	-99 to ±0 to +99	Specifies the mix ratio between the H detail level and the V detail level.
	Crispening	-99 to ±0 to +99	Specifies the crispening level.
	Level Depend	On/Off	Turns the level depend adjustment function on or off.
	Level Depend Level	-99 to ±0 to +99	Specifies the level depend level.
	Frequency	-99 to ±0 to +99	Specifies the central frequency for H detail signals. Larger values give finer details.
	Knee Aperture	On/Off	Turns the knee aperture function on or off.
	Knee Aperture Level	-99 to ±0 to +99	Specifies the knee aperture level.
	Limit	-99 to ±0 to +99	Specifies the detail limiter values for both the white-side and black-side direction.
	White Limit	-99 to ±0 to +99	Specifies the white-side detail limiter value.
	Black Limit	-99 to ±0 to +99	Specifies the black-side detail limiter value.
	V-BLK Limit	-99 to ±0 to +99	Specifies the black-side V detail limiter value.
	V Detail Creation	NAM/G/R+G/Y	Selects the source signal used to generate the V detail signal. NAM: A V detail signal created from the R signal, or a V detail signal created from the G signal, or a V detail signal created from the B signal, whichever is the signal with the highest level G: G signal G+R: Composite signal comprising the G signal and R signal in a 1:1 ratio Y: Y signal
Aperture Makes settings related to aperture correction. Aperture correction is processing to improve resolution by adding high-frequency aperture signals to the video signal, which corrects degeneration due to high-frequency characteristics.	Aperture	On/Off	Turns aperture correction on or off.
	Level	-99 to ±0 to +99	Sets the aperture level.

PAINT			
Menu items	Sub-item	Settings	Description
Skin Detail Makes settings related to skin detail correction. Skin detail correction is processing that increases or decreases the detail level of a specified color range (skin tone range), for the purpose of obtaining attractive reproduction of skin tones.	Skin Detail	On/Off	Turns skin detail correction on or off.
	Area Detection	Color detection screen	Detects the color to be targeted by skin detail correction.
	Area Indication	On/Off	Turns on or off the function that displays a zebra pattern in the area targeted by skin detail correction.
	Level	-99 to ± 0 to +99	Specifies the skin detail level.
	Saturation	-99 to ± 0 to +99	Specifies the saturation of the color targeted by skin detail correction.
	Hue	0 to 359	Specifies the hue of the color targeted by skin detail correction.
	Width	0 to 40 to 90	Specifies a range for the hue of the color targeted by skin detail correction.
Matrix Makes settings related to matrix correction. Matrix correction allows you to adjust the color and vividness of the video. Depending on the effect you want, you can select one from among a number of preset matrixes, which define different parameter sets. Or you can select a user matrix with your own parameters.	Matrix	On/Off	Turns the matrix correction function on or off.
	Preset Matrix	On/Off	Turns the preset matrix function on or off.
	Preset Select	1/2/3/4/5/6	Select a preset matrix. 1: SMPTE-240M equivalent 2: ITU-709 equivalent 3: SMPTE WIDE equivalent 4: NTSC equivalent 5: EBU equivalent 6: PAL equivalent
	User Matrix	On/Off	Turns the user matrix function on or off.
	User Matrix R-G	-99 to ± 0 to +99	Specifies a freely defined R-G user matrix.
	User Matrix R-B	-99 to ± 0 to +99	Specifies a freely defined R-B user matrix.
	User Matrix G-R	-99 to ± 0 to +99	Specifies a freely defined G-R user matrix.
	User Matrix G-B	-99 to ± 0 to +99	Specifies a freely defined G-B user matrix.
	User Matrix B-R	-99 to ± 0 to +99	Specifies a freely defined B-R user matrix.
	User Matrix B-G	-99 to ± 0 to +99	Specifies a freely defined B-G user matrix.

PAINT			
Menu items	Sub-item	Settings	Description
Multi Matrix Makes settings related to multi matrix correction. Multi-matrix correction allows specific colors to be selected for saturation correction in a 16-axis hue space.	Multi Matrix	On/Off	Turns the multi matrix correction function on or off.
	Area Indication	On/Off	Turns on or off the function that displays a zebra pattern in the color area targeted by multi matrix correction.
	Color Detection	Color detection screen	Detects colors targeted by multi matrix correction.
	Axis	B/B+/MG-/MG/MG+/R/R+/YL-/YL/YL+/G-/G/G+/CY/CY+/B-	Specifies a color targeted by multi matrix correction (16-axis mode)
	Hue	-99 to ±0 to +99	Specifies the hue of the color targeted by multi matrix correction for each 16-axis mode.
	Saturation	-99 to ±0 to +99	Specifies the saturation of the color targeted by multi matrix correction for each 16-axis mode.
V Modulation Makes settings related to V modulation shading. V modulation shading corrects vertical imbalances in sensitivity arising from the relationship between a lens and prism.	V Modulation	On/Off	Turns V modulation shading on or off.
	Master V Modulation	-99 to ±0 to +99	Specifies the master V modulation level.
	R V Modulation	-99 to ±0 to +99	Specifies the V modulation level of R signals.
	G V Modulation	-99 to ±0 to +99	Specifies the V modulation level of G signals.
	B V Modulation	-99 to ±0 to +99	Specifies the V modulation level of B signals.
Low Key Saturation Makes settings related to low key saturation correction. You can correct the saturation of colors in dark parts of the video only.	Low Key Saturation	On/Off	Turns low key saturation correction on or off.
	Level	-99 to ±0 to +99	Specifies the saturation of colors in low luminance areas.
	Range	Low/L.Mid/H.Mid/ High	Specifies the luminance level for which low key saturation is enabled.
Noise Suppress Makes settings related to noise suppression (noise compression). You can effectively suppress noise components while preserving fine edge components in the subject.	Noise Suppress	On/Off	Turns noise suppression on or off.

MAINTENANCE Menu

MAINTENANCE			
Menu items	Sub-item	Settings	Description
White Shading Makes settings related to white shading. White shading is required for each different lens to correct irregularities arising from lens characteristics. It corrects luminance and color irregularities in bright areas.	Channel Select	Red /Green/Blue	Selects the target of white shading correction.
	R/G/B White H Saw	-99 to ±0 to +99	Specifies a SAW white shading correction value for the horizontal direction.
	R/G/B White H Para	-99 to ±0 to +99	Specifies a parabola white shading correction value for the horizontal direction.
	R/G/B White V Saw	-99 to ±0 to +99	Specifies a SAW white shading correction value for the vertical direction.
	R/G/B White V Para	-99 to ±0 to +99	Specifies a parabola white shading correction value for the vertical direction.
	White Saw/Para	On /Off	Turns the white shading SAW and parabola correction functions on or off.
Black Shading Makes settings related to black shading correction. Black shading is required for each different lens to correct irregularities arising from lens characteristics. It corrects luminance and color irregularities in dark areas.	Channel Select	Red /Green/Blue	Selects the target of black shading correction.
	R/G/B Black H Saw	-99 to ±0 to +99	Specifies a SAW black shading correction value for the horizontal direction.
	R/G/B Black H Para	-99 to ±0 to +99	Specifies a parabola black shading correction value for the horizontal direction.
	R/G/B Black V Saw	-99 to ±0 to +99	Specifies a SAW black shading correction value for the vertical direction.
	R/G/B Black V Para	-99 to ±0 to +99	Specifies a parabola black shading correction value for the vertical direction.
	Black Saw/Para	On /Off	Turns the black shading SAW and parabola correction functions on or off.
	Master Black	-99 to ±0 to +99	Specifies the master black level.
Master Gain (TMP)	-3dB/0dB/3dB/6dB/9dB/ 12dB/18dB/24dB/30dB/ 36dB/42dB	Specifies a temporary master gain value. (The value is the same as the value selected with the GAIN switch.)	
Battery Makes settings related to batteries.	Info Before End	5% /10%/15%...95%/100%	Specifies a threshold value that triggers a "Battery Before End" warning when a BP-GL65/GL95 battery pack is used.
	Info End	0% /1%/2%/3%/4%/5%	Specifies a threshold value that triggers a "Battery End" warning when a BP-GL65/GL95 battery pack is used.

MAINTENANCE

Menu items	Sub-item	Settings	Description
Battery Makes settings related to batteries.	Sony Before End	11.5V to 17V (0.1V step)	Specifies a threshold value that triggers a “Battery Near End” warning when a BP-L60S/L80S battery pack is used.
	Sony End	11.0V to 11.5V (0.1V step)	Specifies a threshold value that triggers a “Battery End” warning when a BP-L60S/L80S battery pack is used.
	Other Before End	11.5V to 11.8V to 17.0V (0.1V step)	Specifies a threshold value that triggers a “Battery Near End” warning when a non-Sony battery pack is used.
	Other End	11.0V to 14.0V (0.1V step)	Specifies a threshold value that triggers a “Battery End” warning when a non-Sony battery pack is used.
	DC In Before End	11.5V to 11.8V to 17.0V (0.1V step)	Specifies a threshold value that triggers a “Battery Near End” warning when an external power source is connected to the DC IN connector.
	DC In End	11.0V to 14.0V (0.1V step)	Specifies a threshold value that triggers a “Battery End” warning when an external power source is connected to the DC IN connector.
	Detected Battery	Info/Sony/ Other /DC IN	Displays the results of automatic battery pack type detection.
	Type Detection	Auto /Other	Auto: Detect the battery type automatically. Other: Fix battery type detection as “Other”.
	Segment No.10	11.0V to 17.0V (0.1V step)	Specify voltage threshold values that cause remaining capacity segments to go off in the display of remaining battery capacity (<i>see page 30</i>). (The segments go off below the specified value.) These values are used when the battery type has been found to be “Other”.
	Segment No.9	11.0V to 16.0V to 17.0V (0.1V step)	
	Segment No.8	11.0V to 15.0V to 17.0V (0.1V step)	
	Segment No.7	11.0V to 14.0V to 17.0V (0.1V step)	
	Segment No.6	11.0V to 13.5V to 17.0V (0.1V step)	
	Segment No.5	11.0V to 13.0V to 17.0V (0.1V step)	
Segment No.4	11.0V to 12.5V to 17.0V (0.1V step)		
Segment No.3	11.0V to 12.0V to 17.0V (0.1V step)		
Segment No.2	11.0V to 11.5V to 17.0V (0.1V step)		
Segment No.1	11.0V to 17.0V (0.1V step)		

MAINTENANCE			
Menu items	Sub-item	Settings	Description
Audio Makes settings related to audio.	Front MIC Select	Mono/Stereo	Selects whether the front microphone is monaural (Mono) or stereo (Stereo).
	Audio CH3/4 Mode	Ch1/2 / Switch	Selects the input signals for the AUDIO IN CH-3/CH-4 connectors. CH1/2: The same signals as the AUDIO IN CH-1/ CH-2 connectors. Switch: The signals selected with the AUDIO IN CH-3/CH-4 switches.
	Front MIC CH1 Ref	-70dB/-60dB/- 50dB / -40dB/-30dB/-20dB	Selects the reference level for channel 1 of the front microphone.
	Front MIC CH2 Ref	-70dB/-60dB/- 50dB / -40dB/-30dB/-20dB	Selects the reference level for channel 2 of the front microphone.
	Rear MIC CH1 Ref	-70dB/- 60dB -50dB/ -40dB/-30dB/-20dB	Selects the reference input level when the setting of the AUDIO IN CH-1 switch is MIC.
	Rear MIC CH2 Ref	-70dB/- 60dB -50dB/ -40dB/-30dB/-20dB	Selects the reference input level when the setting of the AUDIO IN CH-2 switch is MIC.
	Line Input Ref	+4dB /0dB/-3dB/EBUL	Selects the reference input level when the AUDIO IN CH-1 and AUDIO IN CH-2 switches are set to LINE.
	Min Alarm Volume	Off /Set	Selects the volume when the ALARM knob is turned all the way down. OFF: Almost inaudible SET: Fairly audible
	Speaker Attenuate	Off /3dB/6dB/9dB/12dB	Selects the volume from the monitor or speakers (does not affect earphone volume).
	Headphone Out	Mono /Stereo	Selects whether the earphones are monaural (Mono) or stereo (Stereo).
	Reference Level	- 20dB /-18dB/-16dB/ -12dB/EBUL	Selects the output level of the 1 kHz test signal.
	Reference Out	0dB /+4dB/-3dB/EBUL	Specifies the output level with respect to the reference input level.
	CH1&2 AGC Mode	Mono /Stereo	For automatic adjustment of the input level of analog audio signals recorded on channels 1 and 2, specifies whether to make the adjustments separately for each channel (Mono) or in stereo mode (Stereo).

MAINTENANCE

Menu items	Sub-item	Settings	Description
Audio Makes settings related to audio.	CH3&4 AGC Mode	Mono /Stereo	For automatic adjustment of the input level of analog audio signals recorded on channels 3 and 4, specifies whether to make the adjustments separately for each channel (Mono) or in stereo mode (Stereo).
	AGC Spec	-6dB /-9dB/-12dB/ -15dB/-17dB	Selects the AGC saturation level.
	Limiter Mode	Off /-6dB/-9dB/-12dB/ -15dB/-17dB	For manual audio level adjustments, selects the saturation level for the limiter applied to loud input signals. Select Off if you do not wish to use the limiter.
	Output Limiter	On/Off	Turns the audio output limiter on or off.
	CH1 Wind Filter	On/Off	Turns the channel 1 wind filter on or off.
	CH2 Wind Filter	On/Off	Turns the channel 2 wind filter on or off.
	CH3 Wind Filter	On/Off	Turns the channel 3 wind filter on or off.
	CH4 Wind Filter	On/Off	Turns the channel 4 wind filter on or off.
	Audio SG (1KHz)	On/Off /Auto	Selects whether to output (On) or not output (Off) a 1 kHz test signal in color bar mode. Auto: Output a test signal only when the AUDIO SELECT CH1 switch is set to AUTO .
	MIC CH1 Level	Side1/ Front /Front+Side1	For recording input audio from the front microphone on channel 1, selects the knob that adjusts the audio level. Side1: The LEVEL knob (left) on the side panel Front: The MIC LEVEL knob on the front panel Front+Side1: Adjust with both the LEVEL knob (left) and the MIC LEVEL knob.
	MIC CH2 Level	Side2/ Front /Front+Side2	For recording input audio from the front microphone on channel 2, selects the knob that adjusts the audio level. Side2: The LEVEL knob (right) on the side panel Front: The MIC LEVEL knob on the front panel Front+Side2: Adjust with both the LEVEL knob (right) and the MIC LEVEL knob.

MAINTENANCE

Menu items	Sub-item	Settings	Description
Audio Makes settings related to audio.	Rear1/WRR Level	Side1 /Front/Front+Side1	<p>Selects the knob that adjusts the audio levels of a wireless microphone and a device connected to the AUDIO IN CH-1 connector on the rear panel.</p> <p>Side1: The LEVEL knob (left) on the side panel</p> <p>Front: The MIC LEVEL knob on the front panel</p> <p>Front+Side1: Adjust with both the LEVEL knob (left) and the MIC LEVEL knob.</p>
	Rear2/WRR Level	Side2 /Front/Front+Side2	<p>Selects the knob that adjusts the audio levels of a wireless microphone and a device connected to the AUDIO IN CH-2 connector on the rear panel.</p> <p>Side2: The LEVEL knob (right) on the side panel</p> <p>Front: The MIC LEVEL knob on the front panel</p> <p>Front+Side2: Adjust with both the LEVEL knob (right) and the MIC LEVEL knob.</p>
	Audio CH3 Level	Side3 /Front/Front+Side3	<p>Selects the knob that adjusts the level of audio recorded on channel 3.</p> <p>Side3: The LEVEL knob on side panel</p> <p>Front: The MIC LEVEL knob on the front panel</p> <p>Front+Side3: Adjust with both the LEVEL knob and the MIC LEVEL knob.</p>
	Audio CH4 Level	Side4 /Front/Front+Side4	<p>Selects the knob that adjusts the level of audio recorded on channel 4.</p> <p>Side4: The LEVEL knob on side panel</p> <p>Front: The MIC LEVEL knob on the front panel</p> <p>Front+Side4: Adjust with both the LEVEL knob and the MIC LEVEL knob.</p>

MAINTENANCE

Menu items	Sub-item	Settings	Description
WRR Setting Makes settings related to the wireless tuner.	WRR Valid CH Sel	All/CH1	Selects whether to enable channels 1 and 2 of the wireless receiver (All) or channel 1 only (CH1).
	WRR CH Select	TX1/TX2	Specifies the target channel for other sub-items. TX1: Channel 1 TX2: Channel 2
	WRR Delay Comp	On/Off	Enables (On) or disables (Off) delay compensation for wireless audio input. (When On is selected, the audio in all E-E output is delayed by about 8 ms.)
	TX	---	Displays the name of the transmitter whose signals are being received on the channel selected by WRR CH SELECT.
	TX Audio Peak	---/Peak	Displays whether the AF level of the transmitter whose signals are being received on the channel selected by WRR CH SELECT are over peak.
	TX Input Level	---/Mic/Line	Displays whether the input level of the transmitter whose signals are being received on the channel selected by WRR CH SELECT is set to microphone (Mic) or line (Line).
	TX ATT Level	---	Sets the ATT level of the transmitter whose signals are being received on the channel selected by WRR CH SELECT. (The setting range varies depending on the transmitter.)
	TX LCF Freq	---	Sets the low cut filter frequency of the transmitter whose signals are being received on the channel selected by WRR CH SELECT. (The setting range varies depending on the transmitter.)
	TX System Delay	Auto/0.0ms to 8.0ms	Specifies the amount of audio delay. Auto: Automatically adjusts the amount of delay so that the delay in the audio received from the wireless transmitter is zero. 0.0ms to 8.0ms: Sets the amount of anticipated wireless system delay, for cases in which several wireless systems are being used over a devices such as an audio mixer.

MAINTENANCE

Menu items	Sub-item	Settings	Description
Timecode Makes settings related to timecode.	TC Out	Auto/Generator	Selects the source for timecode output. Auto: During recording, output values generated by the timecode generator, and during playback output values obtained by the timecode reader. Generator: Output values generated by the timecode generator during both recording and playback.
	DF/NDF	DF/NDF	When the Country setting is other than PAL Area, selects drop-frame mode (DF) or non-drop-frame mode (NDF).
	LTC UBIT	Fix/Time	Specifies the data recorded in LTC user bits. Fix: Record user-specified data. Time: Record the current time.
	Counter Display	Counter/Duration	Select the method used to reset the counter value displayed on the viewfinder screen. Counter: Continue to increment until the RESET button is pressed. Duration: Reset each time that recording is started.
Essence Mark Makes settings related to shot marks and clip index picture thumbnails.	Ret Shot Mark 1	On/Off	Specify whether to input Shot Mark1 marks using the RET button on the lens.
	Ret Shot Mark 2	On/Off	Specify whether to input Shot Mark2 marks using the RET button on the lens.

MAINTENANCE

Menu items	Sub-item	Settings	Description
Camera Config Makes settings related to various camcorder operations.	Rec Tally Blink	On/Off	Turns warning flashes by the TALLY indicator on or off. The warnings alert you an almost exhausted battery pack or low remaining media capacity.
	Rec Review	3sec/10sec/Clip	Selects the recording review time. Clip: Review all of the most recently recorded clip.
	HD SDI Remote I/F	Off/Chara/G-Tally/R-Tally	Selects whether to use the function that enables recording control from this camcorder of an external device connected to the HD/SD SDI OUT connector (HD SDI output). When the function is used, also selects the indication that shows whether the external device is recording. Off: Do not use the remote recording control function. Chara: Indicate by the remote device indication in the viewfinder screen. G-Tally: Indicate by the TALLY indicator in the viewfinder (green tally). R-Tally: Indicate by the REC indication (recording/Rec tally) on the viewfinder screen.
	Color Bars Select	ARIB/100%/75%	Selects the color bar type.
	RM Common Memory	On/Off	Selects whether to share (On) or not share (Off) settings between times when a remote control unit is connected and times when the camcorder is used locally.
	RM Rec Start	RM/CAM/PARA	For times when a remote control unit is connected, selects whether recording start/stop buttons are enabled on the camcorder or the remote control unit. RM: Remote control unit CAM: Camcorder PARA: Both
	Image Invert	On/Off	Turns the function that inverts images vertically on or off.

MAINTENANCE			
Menu items	Sub-item	Settings	Description
Preset White Makes settings related to white balance preset values.	Color Temp<P>	1500K to 3200K to 50000K	Specifies the white balance preset value.
	Color Temp Balance<P>	-99 to ±0 to +99	Specifies finer color temperature settings, for use when satisfactory video cannot be obtained with Color Temp<P>.
	R Gain <P>	-99 to ±0 to +99	Specifies the R gain preset value.
	B Gain <P>	-99 to ±0 to +99	Specifies the B gain preset value.
	AWB Enable <P>	On/Off	Turns on and off execution of the AWB (auto white balance) function when the WHITE BAL switch is set to PRST.
White Filter Makes settings related to filters.	ND Filter C.Temp	On/Off	Turns the function that assigns electrical CC filters to ND filters on or off.
	ND FLT C.Temp<1>	3200K /4300K/5600K/6300K	Selects the color temperature for when electrical CC filters are assigned to ND filters.
	ND FLT C.Temp<2-4>	3200K/4300K/ 5600K /6300K	Selects the color temperature for when electrical CC filters are assigned to ND filters.
	Electrical CC<A>	3200K /4300K/5600K/6300K	Selects the color temperature for when the electrical CC filter switching function is assigned to an assignable switch.
	Electrical CC	3200K/ 4300K /5600K/6300K	Selects the color temperature for when the electrical CC filter switching function is assigned to an assignable switch.
	Electrical CC<C>	3200K/4300K/ 5600K /6300K/-----	Selects the color temperature for when the electrical CC filter switching function is assigned to an assignable switch. Select “----” if you do not want to use C.
	Electrical CC<D>	3200K/4300K/5600K/ 6300K /-----	Selects the color temperature for when the electrical CC filter switching function is assigned to an assignable switch. Select “----” if you do not want to use D.

MAINTENANCE

Menu items	Sub-item	Settings	Description
DCC Adjust Makes settings related to DCC (dynamic contrast control).	DCC Function Select	DCC/Fix	Enables or disables automatic knee point adjustment when the OUTPUT/DCC switch is set to CAM, DCC: ON. DCC: Automatically adjust the knee point according to the luminance of the subject. Fix: Set the knee point to a fixed value.
	DCC Dynamic Range	400%/450%/500%/550%/ 600%	Specifies the dynamic range when the OUTPUT/DCC switch is set to CAM, DCC: ON.
	DCC Point	-99 to ±0 to +99	Adjusts the DCC minimum knee point.
	DCC Gain	-99 to ±0 to +99	Specifies gain with respect to the DCC detected value.
	DCC Delay Time	-99 to ±0 to +99	Specifies the DCC control speed (speed of reaction to changes in the video).
	DCC Peak Filter	-99 to ±0 to +99	Adjusts response sensitivity with respect to peaks in DCC detected values.

MAINTENANCE			
Menu items	Sub-item	Settings	Description
Auto Iris2 Makes settings related to auto iris.	Iris Window	1/2/3/4/5/6/Var	Selects the type of iris detection window. Var: Variable
	Iris Window Ind	On/Off	Turns on or off the function that displays a frame marker for the auto iris detection window.
	Iris Level	-99 to ± 0 to +99	Adjusts the level of the auto iris target value.
	Iris APL Ratio	-99 to ± 0 to +99	Adjusts the mix ratio of auto iris detection peak value and average value.
	Iris Var Width	40 to 500 to 999	Adjusts the width of the detection window when the setting of Iris Window is VAR.
	Iris Var Height	70 to 500 to 999	Adjusts the height of the detection window when the setting of Iris Window is VAR.
	Iris Var H Position	-479 to 0 to +479	Specifies the horizontal position of the detection window when the setting of Iris Window is VAR.
	Iris Var V Position	-464 to 0 to +464	Specifies the vertical position of the detection window when the setting of Iris Window is VAR.
	Iris Speed	-99 to ± 0 to +99	Specifies the control speed (speed of reaction to changes in the video). (Larger values specify quicker reaction times.)
	Clip High Light	On/Off	Turns on or off the function that disregards highlights and forces a flatter reaction to high luminance.
Flicker Reduce Makes settings related to flicker reduction. Reduces the flicker that can occur when a subject is shot under a light source with a periodically varying brightness, such as fluorescent lights, due to the relationship with the camcorder's recording frame rate.	Mode	Auto/On/Off	Enables or disables flicker reduction. On: Always enabled. Auto: Enabled when flicker is detected. Off: Disabled
	Frequency	60Hz/50Hz	Set to the frequency of the lighting fixture that is causing the flicker. (The factory default setting is 50 Hz when the Country setting is "PAL Area", 60 Hz when it is other than "PAL Area".)
Genlock Makes settings related to genlock.	H Phase(HD)	-999 to ± 0 to +999	Specifies the H phase of HD output when genlock is enabled.
	H Phase(SD)	-99 to ± 0 to +99	Specifies the H phase of SD output when genlock is enabled.
	Reference	Internal/Genlock	Displays the type of reference signal used by the camcorder.

MAINTENANCE			
Menu items	Sub-item	Settings	Description
ND Comp Makes settings related to ND filter color compensation. Although the differences are very slight, each of the built-in ND filters has different color characteristics. When you switch between ND filters, the white balance may be disturbed. You can correct for these slight color differences automatically by registering compensation values for each filter.	ND Offset Adjust	On/Off	ND filter color compensation function.
	Clear ND Offset	Execute/Cancel	Clears ND filter color compensation values (execute by selecting Execute).
Lens Executes auto flange back adjustment.	Auto FB Adjust	Execute/Cancel	Executes auto flange back adjustment, only for supported lenses (execute by selecting Execute).
Auto Shading Executes auto black shading compensation.	Auto Black Shading	Execute/Cancel	Executes auto shading compensation (execute by selecting Execute).
	Reset Black Shading	Execute/Cancel	Clears black shading compensation values (execute by selecting Execute).
	Master Gain (TMP)	-3dB/0dB/3dB/6dB/9dB/ 12dB/18dB/24dB/30dB/ 36dB/42dB	Specifies a temporary master gain value. (The value is the same as the value selected with the GAIN switch.)
Trigger Mode Makes settings related to triggers for starting and stopping recording.	i.LINK Trigger Mode	Internal/ Both /External	Select Internal when recording start and stop operations target S×S memory cards only. Select External when they target only devices connected to the i.LINK (HDV/DV) or HD/SD SDI OUT connectors. Select Both when they target both memory cards and external devices.
Clock Set Sets the internal clock.	Date/Time		Sets the current date and time.
	12H/24H	12H/ 24H	Selects the 12-hour format (12H) or the 24-hour format (24H) for display of times.
	Date Mode	YYMMDD /MMDDYY/ DDMMYY	Selects the display format for dates. YYMMDD : Year, Month, Day MMDDYY : Month, Day, Year DDMMYY : Day, Month Year
Language Selects the language for messages.	Language	English /Chinese	Selects the language for messages from English or Chinese.

MAINTENANCE			
Menu items	Sub-item	Settings	Description
Hours Meter Makes settings related to the digital hours meter.	Hours(Sys)		Displays the cumulative hours of use (cannot be reset).
	Hours(Reset)		Displays the hours of use (can be reset).
	Reset	Execute/Cancel	Resets Hours(Reset) to 0. (Execute by selecting Execute.)
Version Displays the camcorder firmware version, and updates the firmware.	Version		Displays the version of the camcorder's firmware.
	Version Up	Execute/Cancel	Updates the firmware (execute by selecting Execute).

FILE Menu

FILE			
Menu items	Sub-item	Settings	Description
All Makes settings related to ALL file operations.	Display Mode	Date&Time/Model Name	Selects the items to be displayed in the list box that appears when a file is saved or loaded.
	All File Load	Execute/Cancel	Loads an ALL file (execute by selecting Execute).
	All File Save	Execute/Cancel	Stores an ALL file (execute by selecting Execute).
	File ID		Assigns a name to a file. Names can be up to 16 characters in length.
	All Preset	Execute/Cancel	Return all items to their preset values (execute by selecting Execute).
	Store All Preset	Execute/Cancel	Store the current settings of all items as the preset values (execute by selecting Execute).
	Clear All Preset	Execute/Cancel	Clear the preset values of all items (execute by selecting Execute).
	3Sec Clr Preset	On/Off	Turns on or off the function that clears each preset value when the MENU CANCEL/PRST/ESCAPE switch is pushed up and held for three seconds on the CANCEL/PRST side.

FILE			
Menu items	Sub-item	Settings	Description
Scene Makes settings related to scene file operations.	<input type="checkbox"/> 1	Standard	File number and file ID
	<input type="checkbox"/> 2	Standard	File number and file ID
	<input type="checkbox"/> 3	Standard	File number and file ID
	<input type="checkbox"/> 4	Standard	File number and file ID
	<input type="checkbox"/> 5	Standard	File number and file ID
	<input type="checkbox"/> Standard		Standard settings
	Display Mode	Date&Time/Model Name	Selects the items to be displayed in the list box that appears when a file is saved or loaded.
	Scene Recall Mem	Execute/Cancel	Loads a file from internal memory (execute by selecting Execute).
	Scene Store Mem	Execute/Cancel	Stores a file in internal memory (execute by selecting Execute).
	Scene Recall S×S	Execute/Cancel	Loads a file from an S×S memory card (execute by selecting Execute).
	Scene Store S×S	Execute/Cancel	Stores a file to an S×S memory card (execute by selecting Execute).
	File ID		Assigns a name to a file. Names can be up to 16 characters in length.
	Reference Makes settings related to reference file operations.	Reference Store	Execute/Cancel
Reference Clear		Execute/Cancel	Clear the reference file (execute by selecting Execute).
Reference Load		Execute/Cancel	Load a reference file from an S×S memory card (execute by selecting Execute).
Reference Save		Execute/Cancel	Store a reference file to an S×S memory card (execute by selecting Execute).
File ID			Assigns a name to a file. Names can be up to 16 characters in length.
Scene White Data		On/Off	Selects whether to load (On) or not load (Off) white balance data when Scene >Scene Recall or Scene >Standard is executed.

FILE			
Menu items	Sub-item	Settings	Description
Lens Makes settings related to lens file operations.	Display Mode	Date&Time /Model Name	Selects the items to be displayed in the list box that appears when a file is saved or loaded.
	Lens Recall Mem	Execute/Cancel	Loads a file from internal memory (execute by selecting Execute).
	Lens Store Mem	Execute/Cancel	Stores a file in internal memory (execute by selecting Execute).
	Lens Recall S×S	Execute/Cancel	Loads a file from an S×S memory card (execute by selecting Execute).
	Lens Store S×S	Execute/Cancel	Stores a file to an S×S memory card (execute by selecting Execute).
	File ID		Assigns a name to the most recently loaded file. Names can be up to 16 characters in length.
	Source		Displays the number of the selected file.
	Lens No Offset	Execute/Cancel	Clears a file (execute by selecting Execute).
	Lens Auto Recall	Off /On/S.Number	When the installed lens supports serial communication, specifies whether to automatically load that reference file. Off: Do not use this function. On: Load the reference for the model name and reflect the contents of the file. S.No: For lenses that support serial number communication, load the lens file that corresponds to the serial number and model name, and reflect the contents of that file. For lenses that do not support serial number communication, load the reference for the model name (in the same way as when On is selected).
	Serial Number		Displays the serial number of the installed lens (only for lenses that support serial communication).
	Lens ID		Displays the model name of the installed lens (only for lenses that support serial communication).
	L Manufacturer		Displays the name of the manufacturer of the installed lens (only for lenses that support serial communication).
	M V Modulation	-99 to ±0 to +99	Sets a vertical SAW shading compensation value in the lens file.

FILE			
Menu items	Sub-item	Settings	Description
Lens Makes settings related to lens file operations.	Lens Center H	-40 to 0 to 40	Sets a center marker horizontal position in the lens file.
	Lens Center V	-40 to 0 to 40	Sets a center marker vertical position in the lens file.
	Lens R Flare	-99 to ±0 to +99	Sets a R flare level in the lens file.
	Lens G Flare	-99 to ±0 to +99	Sets a G flare level in the lens file.
	Lens B Flare	-99 to ±0 to +99	Sets a B flare level in the lens file.
	Lens W-R Offset	-99 to ±0 to +99	Sets a R white balance compensation value in the lens file.
	Lens W-B Offset	-99 to ±0 to +99	Sets a B white balance compensation value in the lens file.
	Shading Ch Sel	Red /Green/Blue	Selects the white shading compensation target.
	L R/G/B H Saw	-99 to ±0 to +99	Sets a horizontal SAW white shading compensation value in the lens file.
	L R/G/B H Para	-99 to ±0 to +99	Sets a horizontal parabola white shading compensation value in the lens file.
	L R/G/B V Saw	-99 to ±0 to +99	Sets a vertical SAW white shading compensation value in the lens file.
	L R/G/B V Para	-99 to ±0 to +99	Sets a vertical parabola white shading compensation value in the lens file.

Assigning Functions to Assignable Switches

Using the Assignable SW item of the OPERATION menu, you can assign user-specified functions to the ASSIGN. 0 to 3 switches, the ASSIGNABLE 4 and 5 switches, the COLOR TEMP. button, and the RET button on the lens.

The following tables lists the functions that are assigned when the camcorder is shipped from the factory.

Switch or button	Function	Assignable SW setting
ASSIGN. 0 switch	No assignment	Off
ASSIGN. 1 switch	Execute EZ mode, according to the setting of OPERATION > TLCS.	EZ Mode
ASSIGN. 2 switch	No assignment	Off
ASSIGN. 3 switch	No assignment	Off
ASSIGNABLE 4 switch	No assignment	Off
ASSIGNABLE 5 switch	No assignment	Off
RET button	During recording or playback: Write a shot mark. In the other states: Conduct a recording review (if playback is allowed).	Lens RET
COLOR TEMP. button	Adjust the white balance with the preset white balance value of 5600K.	Color Temp SW 5600K

Functions that can be assigned to the ASSIGN. 0 switch

Assignable switch setting	Function	State when camcorder is next powered on
Off	No assignment	—
Marker	Turn the display of all markers on or off.	Setting retained
ATW Hold	Hold the white balance setting in the ATW (auto-tracking white balance) mode	—
Picture Cache	Turn the picture cache function on or off.	Setting retained
Freeze Mix	Execute the freeze mix function.	—
Focus Mag	Turn the focus magnification function on or off.	Setting not retained
Zebra	Turn zebra display on or off.	Setting not retained
Shot Mark1	Write Shot Mark1.	—
Shot Mark2	Write Shot Mark2.	—
OK Mark	Add or delete an OK mark.	—

Functions that can be assigned to the ASSIGN. 2 switch

Note

Immediately after you assign a function to the ASSIGN. 2 switch or you switch the recording format, the setting of the switch at that point may not match the camcorder's internal state. After assigning a function, switch the ASSIGN. 2 switch or power the camcorder off and on again.

Assignable switch setting	Function
Off	No assignment
Front Mic	Switch between stereo and monaural when a stereo microphone is connected.
Marker	Turn the display of all markers on or off.
Picture Cache	Turn the picture cache function on or off.
Zebra	Turn zebra display on or off.
Digital Extender	Turn the screen magnification function on or off (only when the option for digital extender is installed).

Functions that can be assigned to the ASSIGN. 1 and 3 switches, the ASSIGNABLE 4 and 5 switches, and the COLOR TEMP. button

Assignable switch setting	Function	State when camcorder is next powered on
Off	No assignment	—
Front Mic	Switch between stereo (On) and monaural (Off) when a stereo microphone is connected.	Setting retained
Marker	Turn the display of all markers on or off.	Setting retained
Last Clip Delete	Delete the most recently recorded clip.	—
ATW	Turn ATW (auto tracing white balance) mode on or off.	Setting not retained
ATW Hold	Hold the white balance setting in the ATW mode.	—
EZ Mode	Execute EZ mode according to the setting of OPERATION >TLCS.	Setting retained
Turbo Gain	Execute Turbo Gain according to the setting of OPERATION >Gain Switch >Gain Turbo.	Setting not retained
Rec Review	Conduct a recording review.	—
Rec	Start or stop recording.	—
Picture Cache	Turn the picture cache function on or off.	Setting retained
Freeze Mix	Execute the freeze mix function.	Setting not retained
Spotlight	Turn the spotlight function in auto iris mode on or off.	Setting retained
Backlight	Turn the backlight function in auto iris mode on or off.	Setting retained
EVF Mode	Switch the viewfinder screen between B&W (On) and color (Off).	Setting retained
BRT Disp	Turn the display of the brightness level on or off.	Setting retained
Histogram	Turn the histogram display on or off.	Setting retained
Lens Info	Switch the depth of field indication between off, displayed in meters, and displayed in feet.	Setting retained

Assignable switch setting	Function	State when camcorder is next powered on
Zoom Tele/Wide	When a lens that supports serial communication is installed, assign the Zoom Tele function to ASSIGNABLE 4, and assign the Zoom Wide function to ASSIGNABLE 5 (displayed only when <4> and <5> are set).	—
Zoom Wide/Tele	When a lens that supports serial communication is installed, assign the Zoom Wide function to ASSIGNABLE 4, and assign the Zoom Tele function to ASSIGNABLE 5 (displayed only when <4> and <5> are set).	—
Manual Focus Assist	Turn the manual focus assist function on or off.	Setting retained
Focus Mag	Turn the focus magnification function on or off.	Setting not retained
Zebra	Turn zebra display on or off.	Setting not retained
Lens RET	During recording or playback: Write a shot mark. In the other states: Conduct a recording review (if playback is allowed).	—
Return Video	Display return video signals.	—
Shot Mark1	Write Shot Mark1.	—
Shot Mark2	Write Shot Mark2.	—
OK Mark	Add or delete an OK mark.	—
Color Temp SW 3200K	Adjust the white balance with a 3200K preset value.	Setting retained
Color Temp SW 4300K	Adjust the white balance with a 4300K preset value.	Setting retained
Color Temp SW 5600K	Adjust the white balance with a 5600K preset value.	Setting retained
Color Temp SW 6300K	Adjust the white balance with a 6300K preset value.	Setting retained
Electrical CC	Function that switches the electrical CC filter (3200K/4300K/5600K/6300K) applied to white balance adjustment values. Each press of the switch or button switches in the order 3200K→4300→5600K→6300K. These can also be applied from a menu (apply with Electrical CC<A><C><D>).	Setting retained
	Note This function is not available when White Filter >ND Filter C.Temp in the Maintenance menu is set to On. If you set ND Filter C.Temp to On after assigning the function, the assignable switch ceases to function.	
CC5600K	Apply a 5600K electrical CC filter to white balance adjustment values.	Setting retained
Digital Extender	Turn the screen magnification function on or off (only when the option for digital extender is installed).	Setting not retained

Functions that can be assigned to the RET button on the lens

Assignable switch setting	Function	State when camcorder is next powered on
Off	No assignment	—
Lens RET	During recording or playback: Write a shot mark. In the other states: Conduct a recording review (if playback is allowed).	—
Return Video	Display return video signals.	—
Rec Review	Execute recording review.	—
Shot Mark1	Write Shot Mark1.	—
Shot Mark2	Write Shot Mark2.	—
OK Mark	Add or delete an OK mark.	—
Focus Mag	Turn the focus magnification function on or off.	Setting not retained

Saving and Loading Settings

You can save setup menu settings in the camcorder's internal memory and on S×S memory cards. This allows you to quickly recall an appropriate set of menu settings for the current situation.

Setting data is saved in the following categories.

ALL files: ALL files save the setting data of all menus. You can save up to 64 ALL files on an S×S memory card.

Note

Device specific data (shading, output levels, and other data that requires adjustment for the specific device) is not saved.

Scene files: Scene file save adjustments to PAINT menu items for the purpose of shooting a particular scene. You can save up to five scene files in the camcorder's internal memory and up to 64 scene files on an S×S memory card.

Reference files: Reference files save the reference values that are set when you execute FILE >Scene >Standard in the setup menu. You can save one reference file in the camcorder's internal memory and one on an S×S memory card.

Lens files: Lens files save the setting data used to compensate for lens characteristics, such as flare, white shading, white balance and center markers. You can save up to 32 lens files in the camcorder's internal memory and up to 64 lens files on an S×S memory card.

The first settings stored in a file are called "preset" values.

Even after loading files to set up the camcorder, and overwriting original files with new settings, you can still recover preset values and reset files to their initial states (see page 136).

Saving Setting Data

This section explains how to save setting data in an ALL file.

Before starting, insert a writable S×S memory card into a memory card slot.

See "Basic Setup Menu Operations" (page 94) for information about menu operations.

1 Select FILE >All in the setup menu.

To assign a name to the data before saving it

Assign a name before proceeding to step 2.

For details, see "To assign names to files" (page 136).

2 Select All File Save >Execute.

An ALL file list box appears.

File numbers where "No File" is displayed are empty file numbers. File numbers with a file name or a date and time are the number of files that already contain data.

3 Turn the MENU knob to select the desired file number.

4 Press the MENU knob.

A confirmation message appears.

5 To execute the save, select [Execute], and then press the MENU knob. To cancel the save, select [Cancel], and then press the MENU knob.

If you choose to execute the save, the ACCESS lamp lights. A completion message appears and the ACCESS lamp goes out when the data has been saved to the S×S memory card.

If an error message appears

One of the following error messages may appear during execution of the save, or as soon as you select [Execute]. In this case, the file is not saved to the S×S memory card.

Error message	Problem	What to do
NG:Cannot Save	No recordable media is inserted.	Insert recordable media.
NG:Media Full	The media is full.	Use media with free capacity remaining.

To assign names to files

Assigning a name before you save data in an ALL file can make it easier to distinguish your files.

The following characters can be used in file names.

Alphanumeric characters (a–z, A–Z, 0–9) and special characters (! # \$ % & ' () * + , - . / : ; < = > ? @ [\] ~)

- 1 **Select FILE >All >File ID in the setup menu.**
- 2 **Turn the MENU knob to select a character, and then press the MENU knob.**
- 3 **Repeat step 3.**
- 4 **When you have finished entering characters, press the MENU knob to move the cursor to “SET”, and then press the MENU knob.**

The specified name is displayed.

When you save the file (see page 135), the data will be saved under this name.

Loading Setting Data

Note

When you load a file from an S×S memory card, the data saved in the camcorder’s internal memory is overwritten.

See “Basic Setup Menu Operations” (page 94) for information about menu operations.

- 1 **Select FILE >All in the setup menu.**
- 2 **Select All File Load >Execute.**
A list box of ALL files appears.
File numbers where “No File” is displayed are empty file numbers. File numbers with a file name or a date and time are the number of files that already contain data.

- 3 **Turn the MENU knob to select the desired file number.**
- 4 **Press the MENU knob.**
A confirmation message appears.
- 5 **To execute the load, select [Execute], and then press the MENU knob.**
To cancel the load, select [Cancel], and then press the MENU knob.

If you choose to execute the load, the ACCESS lamp lights. The ACCESS lamp goes out and a completion message appears when the data has been loaded from the S×S memory card.

If an error message appears

One of the following error messages may appear during execution of the load, or as soon as you select [Execute]. In this case, the file is not loaded from the S×S memory card.

Error message	Problem	What to do
NG:No Data	<ul style="list-style-type: none"> • There is no readable media • The specified file does not exist on the media 	Insert the media that contains the file you want.

Resetting a File after Changing Its Contents

See “Basic Setup Menu Operations” (page 94) for information about menu operations.

- 1 **Select FILE >All in the setup menu.**
- 2 **Select [All Preset], and then press the MENU knob.**
- 3 **To execute the reset, select [Execute], and then press the MENU knob.**
To cancel the reset, select [Cancel], and then press the MENU knob.
If you choose to execute the reset, all settings in the ALL file are reset to preset values.

Saving and Loading Scene Files

Scene files allow you to save the following types of data.

- Values set in the PAINT menu
- Shutter speeds set in standard mode or ECS mode
- White balance data

The data that is saved and loaded depends on the setting of FILE >Reference >Scene White Data in the setup menu.

Saving Scene Files

To save a scene file to an S×S memory card, insert the card into a memory card slot and then proceed as follows.

See “Basic Setup Menu Operations” (page 94) for information about menu operations.

- 1 Select FILE >Scene in the setup menu.**

To assign a name to the data before saving it
Assign a name before proceeding to step 2.
For details, see “To assign names to files” (page 136).
- 2 Select Scene Store Mem or Scene Store S×S.**
Select Scene Store Mem if you want to save the data in the camcorder’s internal memory, and select Scene Store S×S if you want to save the data on an S×S memory card.
- 3 Press the MENU knob.**
A list box of scene files appears.
File numbers where “No File” is displayed are empty file numbers
- 4 Select the file number under which you want to save the data, and then press the MENU knob.**
A confirmation message appears.

- 5 To execute the save, select [Execute], and then press the MENU knob. To cancel the save, select [Cancel], and then press the MENU knob.**

If you selected Scene Store S×S in step 2, the ACCESS lamp lights when you execute the save.

When the data has been saved to the S×S memory card, a completion message appears and the ACCESS lamp goes out.

Loading Scene Files

To load a scene file from an S×S memory card, insert the S×S memory card into a memory card slot, and then proceed as follows.

See “Basic Setup Menu Operations” (page 94) for information about menu operations.

- 1 Select FILE >Scene in the setup menu.**
- 2 Select Scene Recall Mem or Scene Recall S×S.**
Select Scene Recall Mem if you want to load the file from the camcorder’s internal memory, and select Scene Recall (S×S) if you want to load the file from an S×S memory card.
- 3 Press the MENU knob.**
A list box of scene files appears. File numbers where “No File” is displayed are empty file numbers.
- 4 Select the desired file number, and then press the MENU knob.**
A confirmation message appears.
- 5 To execute the load, select [Execute], and then press the MENU knob. To cancel the load, select [Cancel], and then press the MENU knob.**
If you selected Scene Recall S×S in step 2, the ACCESS lamp lights when you execute the load.
When the data has been loaded from the S×S memory card, a completion message appears and the ACCESS lamp goes out.

Saving and Loading Lens Files

Setting Lens File Data

Use FILE >Lens (see page 129) in the setup menu to set the data in lens files.

You can set the following data and save it as a lens file.

Setting data	Sub-items
V modulation shading compensation values	M V Modulation
Center marker position	Lens Center H Lens Center V
Flare level	Lens R Flare Lens G Flare Lens B Flare
White balance compensation value	Lens W-R Offset Lens W-B Offset
White shading compensation value	L R/G/B H Saw L R/G/B H Para L R/G/B V Saw L R/G/B V Para

See “Basic Setup Menu Operations” (page 94) for information about menu operations.

Saving Lens Files

To save a lens file to an S×S memory card, insert the card into a memory card slot and then proceed as follows.

See “Basic Setup Menu Operations” (page 94) for information about menu operations.

1 Select FILE >Lens in the setup menu.

To assign a name to the data before saving it

Assign a name before proceeding to step 2.

For details, see “To assign names to files” (page 136).

2 Select Lens Store Mem or Lens Store S×S, and press the MENU knob.

Select Lens Store Mem if you want to save the data in the camcorder’s internal memory, and select Lens Store S×S if you want to save the data on an S×S memory card.

3 To execute the save, select [Execute], and then press the MENU knob. To cancel the save, select [Cancel], and then press the MENU knob.

If you select [Execute], a list box of lens file number appears. File numbers where “No File” is displayed are empty file numbers.

4 Select the file number under which you want to save the data, and then press the MENU knob.

A confirmation message appears.

5 To execute the save, select [Execute], and then press the MENU knob. To cancel the save, select [Cancel], and then press the MENU knob.

If you selected Lens Store S×S in step 2, the ACCESS lamp lights when you execute the save.

When the data has been saved to the S×S memory card, a completion message appears and the ACCESS lamp goes out.

Loading Lens Files

To load a lens file from an S×S memory card, insert the S×S memory card into a memory card slot, and then proceed as follows.

See “Basic Setup Menu Operations” (page 94) for information about menu operations.

1 Select FILE >Lens in the setup menu.

2 Select Lens Recall Mem or Lens Recall S×S, and press the MENU knob.

Select Lens Recall Mem if you want to load the file from the camcorder’s internal memory, and select Lens Recall S×S if you want to load the file from an S×S memory card.

3 To execute the load, select [Execute], and then press the MENU knob.

To cancel the load, select [Cancel], and then press the MENU knob.

If you select [Execute], a list box of lens files appears. File numbers where “No File” is displayed are empty file numbers.

4 Select the desired file number, and then press the MENU knob.

A confirmation message appears.

5 To execute the load, select [Execute], and then press the MENU knob. To cancel the load, select [Cancel], and then press the MENU knob.

If you selected Lens Recall S×S in step 2, the ACCESS lamp lights when you execute the load.

When the specified lens file has been loaded from the S×S memory card, a completion message appears and the ACCESS lamp goes out.

Loading Lens Files Automatically

When you are using a lens that support serial communication, you can set up the camcorder by automatically loading the lens file that corresponds to the lens settings (Lens Auto Recall function).

To use the Lens Auto Recall function, set FILE >Lens >Lens Auto Recall in the setup menu to one of the following.

On: Load the lens file that corresponds to the model name.

Off: Do not use the Lens Auto Recall function.

Serial Number: Load the lens file that corresponds to the model name and serial number (when the lens supports communication of the serial number).

If the lens does not support communication of the serial number, both settings load the lens file that corresponds to the model name.

You can connect an RM-B150/B750 Remote Control Unit and operate this camcorder. For connection and operation of the RM-B150/B750, refer to the Supplement supplied in the CD-ROM (labeled “Manuals for Solid-State Memory Camcorder”).

Connecting External Monitors

Select the output signal and use an appropriate cable for the monitor to be connected.

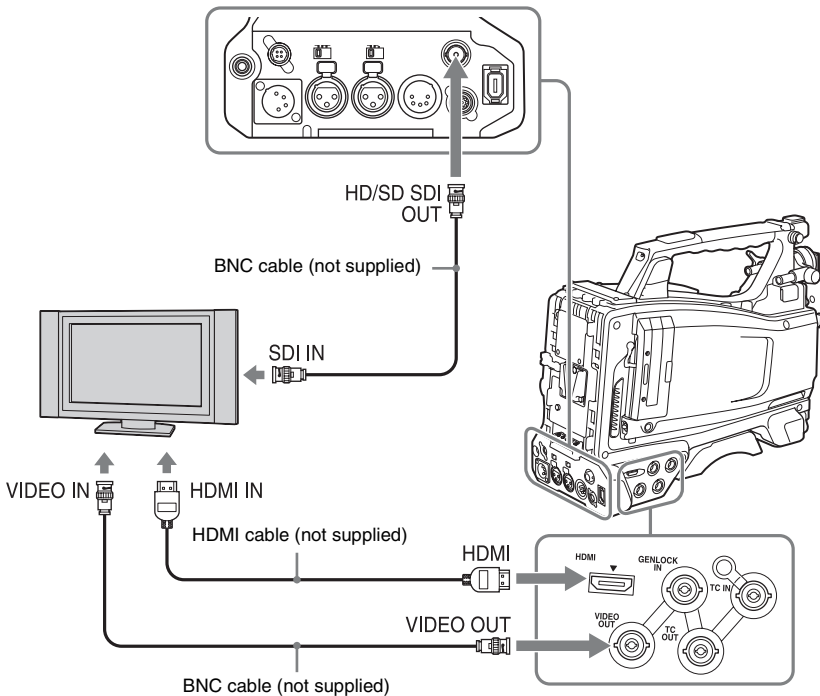

Regardless of whether the signal is HD or SD, the same status information and menus can be displayed on the external monitor as those on the viewfinder screen.

Note

SD signals down-converted for output have the following restrictions:

Images of 50P/50i/25P are output as PAL signals, those of 59.94P/59.94i/29.97P are output as NTSC signals, and those of 23.98P are output as 2-3 pulled-down NTSC signals.

HD/SD SDI OUT connector (BNC)

The HD/SD SDI OUT connector can be used to connect a device that supports SDI. The device type can be a monitor, switcher, or VTR or other recording device.

The output from this connector can be turned on and off with OPERATION >Input/Output >SDI Output in the setup menu (*see page 98*).

For connection, use a BNC cable (not supplied).

HDMI connector

The HDMI connector can be used to connect a device that supports HDMI. The device type can be a monitor or VTR or other recording device.

The output from this connector can be turned on and off with OPERATION >Input/Output >HDMI Output in the setup menu (*see page 98*).

For connection, use an HDMI cable (not supplied).

VIDEO OUT connector

The VIDEO OUT connector can be used to connect a device that supports analog composite signal. The device type can be a monitor or VTR or other recording device.

The analog composite signal output from this connector is the same as the NTSC or PAL encoded signal that is output from the HD/SD SDI OUT connector when the setting of output is SD signal (you can switch between NTSC and PAL with OPERATION >Format >Country in the setup menu (*see page 96*)).

To input the VIDEO OUT connector output signal to an external analog composite device, it may be necessary to change the input signal setting of that external device to be matched with the analog composite signal setting for the VIDEO OUT connector.

To input camcorder output audio to an external device such as a monitor or VTR or other recording device, connect the audio output of the AUDIO OUT connector to the audio input of that external device.

For connection, use a BNC cable (not supplied).

i.LINK (HDV/DV) connector

The i.LINK (HDV/DV) connector supports HDV and DV input/output. However, DV streams cannot be recorded on this camcorder.

This connector can be used to connect a device that supports i.LINK (HDV). The device type can be a monitor, read/write device such as VTR or HDD, or computer.

To input/output HDV signals

HDV input/output is supported when the video format is an HDV compatible format (SP 1440/59.94i, SP 1440/50i, or SP 1440/23.98P), Input/Output >Output&i.LINK in the OPERATION menu is set to [HD&HDV] or [SD&HDV], and Input/Output >i.LINK I/O is set to [Enable]. When the video format is SP 1440/23.98P, a 59.94i HDV signal subjected to 2-3 pulldown processing is output.

To input/output DV signals

DV input/output is supported under either of the following conditions.

- Input/Output >i.LINK I/O in the OPERATION menu is set to [Enable] on SD mode.
- On HD mode, the video format is other than DV incompatible formats (HQ 1920/23.98P, HQ 1440/23.98P, and HQ 1280/23.98P), Input/Output >Output&i.LINK is set to [SD&DV], and Input/Output >i.LINK I/O is set to [Enable].

Operating Clips with a Computer

The clips recorded on S×S memory cards with this camcorder can be controlled on a computer or edited using the optional nonlinear editing software.

For these purposes, the clips on an S×S memory card can be operated by directly loading the card in a computer or by connecting the camcorder or the optional SBAC-US10 S×S Memory Card USB Reader/Writer to the computer, using a USB cable as shown below.

Preparations

To use the ExpressCard slot of a computer

If the computer is equipped with an ExpressCard/34 or ExpressCard/54 slot, you can directly insert the S×S memory card containing clips recorded with this camcorder and access to the files.

For the operating requirements for the computer, see “Using the CD-ROM” (page 12).

Note

The S×S Device Driver Software on the CD-ROM supplied with the camcorder must be installed on your computer. Before installation, be sure to read the enclosed S×S Device Driver Software End-User License Agreement.

For information on installation of the driver software, refer to the ReadMe on the supplied CD-ROM.

For support information for the driver software, visit the following URL:

<http://www.sony.net/S×S-Support/>

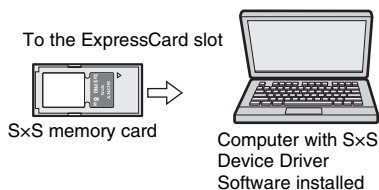

With a Windows computer

Check that a Removable Disk appears in My Computer. This indicates normal status.

With a Macintosh computer

An icon is displayed on the menu bar.

To connect with a USB cable

When you connect the camcorder or the SBAC-US10 S×S Memory Card USB Reader/Writer (optional) using a USB cable (not supplied), the memory card in the slot is acknowledged as an extended drive by the computer.

When two memory cards are mounted in this camcorder, they are acknowledged as two independent extended drives by the computer.

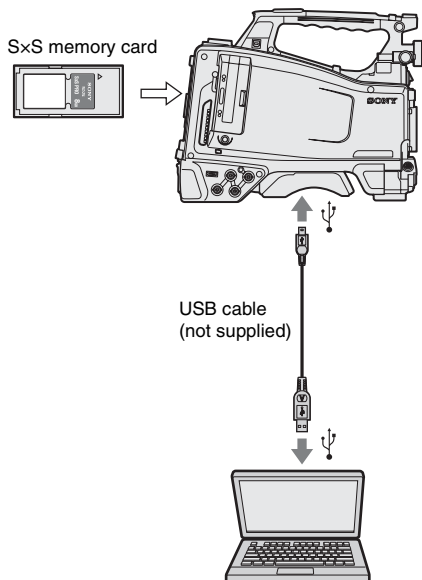

Notes

- When connecting the USB cable to the computer, be careful to check the form and direction of the USB connector.
- The camcorder does not work on the bus power from the computer.

To connect a computer to the USB connector

Note

When a computer is connected to the USB connector of the camcorder and at the same time an optional PHU-60K/120K/120R Professional Hard Disk Unit (powered from a battery) is connected to the computer, battery exhaustion on the PHU-60K/120K/120R (indicated by a Battery End warning) disables the following.

- To guard the PHU-60K against access from the computer
- To disconnect the PHU-60K's cable from the memory card slot or plug again the cable into the slot
- To turn on the tally indicator on the viewfinder screen to warn the operator

When you connect a computer to the USB connector with a USB cable (not supplied), the message “Connect USB Now?” is displayed to prompt you to confirm that you wish to enable the USB connection.

If you select “Cancel” or push the MENU CANCEL/PRST/ESCAPE down to the ESCAPE side or if you disconnect the USB cable, the message “Connect USB Now?” disappears.



If you select “Execute” and press the MENU knob, the USB connection is enabled and this camcorder is recognized as an extension drive. You can carry out the same operations by using the arrow buttons (↑, ↓, ←, ⇒) (see page 21).



If the USB connection is enabled during recording/playback operation, the operation is stopped and the message “USB Connecting” appears on the viewfinder screen.

At this time, the output signal from the VIDEO OUT connector, HDMI connector, and HD/SD SDI OUT connector changes to a black signal.

Notes

- The camcorder cannot be operated for recording, playback, and so on while the message “USB Connecting” is displayed.
- When the computer accesses the media loaded in the camcorder, do not try to carry out the following operations.
 - Operating the camcorder (turning the power on/off, switching the operation mode, etc.)
 - Removing or loading a media from an active slot (being accessed from the computer)
 - Removing or connecting the USB cable

Disabling the USB connection

To disable the USB connection, follow the same procedure as that for removing a device from the computer.

To enable the USB connection again, first disconnect the USB cable and then reconnect it. The message “Connect USB Now?” appears again.

Note

If you connect the camcorder to the computer using an i.LINK cable, you cannot use the computer to operate files stored in a recording media loaded in the memory card slot of this camcorder.

To remove an S×S memory card

Windows

1. Click on the icon of “Safely Remove Hardware” on the task bar of the computer.
2. Select “Safely remove S×S Memory Card - Drive(X:)” from the displayed menu.
3. Check that the Safe To Remove Hardware message appears then remove the card.

Macintosh

Drag the S×S memory card icon on the desktop to Trash.

If the S×S memory card icon is located on Finder, click on the eject icon on its side.

Note

Do not select “Card Power Off” from the S×S memory card icon displayed on the menu bar.

To use the XDCAM EX Clip Browsing Software

To copy clips to the local disk of a computer, the XDCAM EX Clip Browsing Software must be used.

Install the XDCAM EX Clip Browsing Software on the supplied CD-ROM to your computer. Although the data regarding recorded materials are stored over multiple files and folders, you can easily handle the clips without considering such data and directory structure by using the XDCAM EX Clip Browsing Software.

Note

If you operate, e.g. copy the clips on the S×S memory card by using the Explorer (Windows) or Finder (Macintosh), the subsidiary data contained by the clips

may not be maintained. To avoid such a problem, use the XDCAM EX Clip Browsing Software.

For the operating requirements, see “XDCAM EX web sites” (page 12), and for installation and operations, refer to the User’s Guide contained in the CD-ROM.

For support information on the XDCAM EX Clip Browsing Software, visit the web sites shown in “XDCAM EX web sites” (page 12) or on the cover page of the supplied CD-ROM.

To use a nonlinear editing system

For a nonlinear editing system, optional editing software that corresponds to the recording formats used with this camcorder is required. Store the clips to be edited on the HDD of your computer in advance, using the supplied XDCAM EX Clip Browsing Software. Some editing software may not operate properly. Be sure to confirm before use that it conforms to the recording formats used with this camcorder.

To use Final Cut Pro of Apple Inc.

It is necessary to convert the clips to files that can be edited with the Final Cut Pro, using XDCAM Transfer.

For information on XDCAM Transfer, visit the web sites shown in “XDCAM EX web sites” (page 12) or on the cover page of the supplied CD-ROM.

Connecting an External Device (i.LINK Connection)

You can record the same images as those recorded on the memory card in this camcorder on an external device connected to the i.LINK (HDV/DV) connector, or record the playback picture of the external device on the memory card in the camcorder.

When you connect the camcorder to a non-linear editing system that supports HDV format, you can edit the images recorded on the memory card in the camcorder.

Notes

- When you set OPERATION >Input/Output >Output&i.LINK in the setup menu to [480P (570P)], no signal is output from the HD/SD SDI OUT connector.
- Use the i.LINK (HDV/DV) connector only for one-to-one i.LINK connection.
- When you change a setting which affects output signals from the i.LINK (HDV/DV) connector, such as HD/SD, HD System Line, System Frequency, and Rec Format under OPERATION >Format in the setup menu or i.LINK I/O and Down Converter under OPERATION >Input/Output in the setup menu, disconnect the i.LINK cable and change the setting. Changing such a setting with the i.LINK cable connected may cause improper operation of the connected i.LINK device.
- The external signal input via the i.LINK connection that can be recorded on the camcorder is HDV streams only. You cannot record DV streams via the i.LINK connection.

Recording the Camera Picture on an External Device

The picture being shot with this camcorder is output as an HDV or DV stream via the i.LINK (HDV/DV) connector. It can be recorded on a connected HDV or DVCAM recorder in synchronization with a recording start/stop operation on this camcorder.

- 1 Perform the preparatory settings of the camcorder.

- Set OPERATION >Input/Output >Output & i.LINK in the setup menu (see page 98) to “HD & HDV” or “SD & HDV”.

HD & HDV or SD & HDV: To output an HDV stream in HD mode when the video format is set to an HDV compatible format (SP 1440/59.94i, SP 1440/50i, or SP 1440/23.94P)

SD & DV: To output a DV stream

- Set OPERATION >Input/Output >i.LINK I/O in the setup menu to [Enable].
- Set MAINTENANCE >Trigger Mode >i.LINK Trigger Mode in the setup menu (see page 126) to [Both] or [External].

Both: To perform recording both on the memory card in this camcorder and on the external device

External: To perform recording only on the external device





2 Set the external device to recording standby status.

For operations of the external device, refer to the operation manual of that device.

3 Start recording.

The external device starts recording in synchronization.

The status of the external device is displayed in the i.LINK status indication area (see page 31) on the viewfinder screen.

Indication	Status of the external device
STBY 	In HDV recording standby
●REC 	In HDV recording
STBY 	In DV recording standby
REC 	In DV recording

Notes

- Operation may be different depending on the type of external device.
- Although there is some time lag from which you start recording until the i.LINK status indication changes, the same pictures are recorded on the memory card in this camcorder and the external device if MAINTENANCE >Trigger Mode >i.LINK Trigger Mode is set to [Both].
- While you can record shot marks on the memory card during recording, they are not added to the pictures recorded on the external device.

Nonlinear Editing

You can transfer an HDV stream to a nonlinear editing system connected via the i.LINK (HDV/DV) connector.

Notes

- The i.LINK (HDV/DV) connector of this camcorder is a 6-pin connector. Check the number of pins of the i.LINK connector on your computer and use an appropriate i.LINK cable.
- In searching pictures of this camcorder on the computer, it may take some time until the display is reflected on the computer.
- If the playback clip is short or the playback starting point is near the end of the clip, the i.LINK signal may be interrupted between the clip and the next clip. When you try to capture such a signal using the nonlinear editing system, a malfunction may occur, depending on the nonlinear editing software in use.
- If you specify a search speed other than 4, 15, or 24 times normal with the nonlinear editing system, no i.LINK signal is fed out. In such a case, the picture on the LCD monitor may stay frozen.
- High-speed playback picture may not be displayed on the computer screen, depending on the nonlinear editing software in use.

Setting on this camcorder

Set OPERATION >Input/Output >i.LINK I/O in the setup menu to [Enable].

For operations of the nonlinear editing software, refer to the operation manual of the software.

Recording External Input Signals

The HDV stream input from a device connected via the i.LINK (HDV/DV) connector can be recorded on an SxS memory card in this camcorder.

The timecodes superimposed on the i.LINK input are recorded regardless of the settings of the camcorder.

Note

DV stream cannot be recorded.

1 Set the external signal to a format that can be recorded on the camcorder.

Select an HDV compatible format (SP 1440/59.94i, SP 1440/50i, or SP 1440/23.94P) for the video format.

2 Make the following settings with OPERATION >Input/Output in the setup menu (see page 98).

- Set Output&i.LINK to [HD&HDV] or [SD&HDV].
- Set i.LINK I/O to [Enable].
- Set Source Select to [i.LINK].

The input video is displayed on the viewfinder screen or the monitor connected to the VIDEO OUT connector.

Audio signals are output through the built-in speakers, the headphones connected to the EARPHONE connector, and the speakers of the monitor connected to the VIDEO OUT connector.

3 Start the recording.

Notes

- An error is generated in the following cases. In such a case, cancel Recording mode.
 - The video format of input signal does not match that specified on the camcorder.
 - A copy-protected stream is being fed in.
- If the input to the camcorder becomes no signal during recording, the TALLY indicators, the tally indicator on the front of the viewfinder, and the REC indication (●REC) on the viewfinder screen flash, indicating that no signal is being recorded on the SxS memory card. When an input signal is resumed, recording is restarted, incrementing the clip number on the memory card.

Testing the Camcorder

Check the functions of the camcorder before setting out for a shooting session, preferably by recording and playing back video and audio signals.

Maintenance

Cleaning the Viewfinder

Use a dust blower to clean the lens, the LCD screen, and mirror inside the viewfinder barrel.

Note















Never use organic solvents such as thinners.

Note about the Battery Terminal

The battery terminal of this unit (the connector for battery packs and AC adaptors) is a consumable part.





Power may not be supplied to the unit properly if the pins of the battery terminal are bent or deformed by shock or vibrations, or if they become corroded due to prolonged outdoor use. Periodic inspections are recommended to keep the unit working properly and to prolong its usable lifetime.

Contact a Sony service or sales representative for more information about inspections.

Battery Near End	WARNING indicator	Warning sound	Tally/REC	Battery remaining
		●)))))))))		
	Problem	Operation in the recorder module	Action to take	
	The battery power will be exhausted soon.	Recording continues.	Charge the battery pack at the earliest opportunity.	
Battery End	WARNING indicator	Warning sound	Tally/REC	Battery remaining
		●)))))))))		
	Problem	Operation in the recorder module	Action to take	
	The battery pack is exhausted. Recording cannot be performed.	Recording stops.	Connect a power source via the DC IN connector or stop operation to charge the battery pack.	
Temperature High	WARNING indicator	Warning sound	Tally/REC	Battery remaining
		●)))))))))		—
	Problem	Operation in the recorder module	Action to take	
	The internal temperature has risen above a safe operation limit.	Recording continues.	Suspend operation, turn off the power, and wait until the temperature falls.	
Voltage Low	WARNING indicator	Warning sound	Tally/REC	Battery remaining
		●)))))))))		
	Problem	Operation in the recorder module	Action to take	
	The DC IN voltage has become low (stage 1).	Recording continues.	Check the power supply.	
Insufficient Voltage	WARNING indicator	Warning sound	Tally/REC	Battery remaining
		●)))))))))		
	Problem	Operation in the recorder module	Action to take	
	The DC IN voltage is too low (stage 2). Recording cannot be performed.	Recording stops.	Connect other power source.	
Battery Error Please Change Battery.	WARNING indicator	Warning sound	Tally/REC	Battery remaining
	—	—	—	—
	Problem	Operation in the recorder module	Action to take	
	An error was detected with the battery pack.	Recording stops.	Replace the battery pack with a normal one.	

Backup Battery End Please Change.	WARNING indicator	Warning sound	Tally/REC	Battery remaining
	—	—	—	—
	Problem	Operation in the recorder module	Action to take	
	The remaining power of the backup battery is insufficient.	Recording continues.	Refer to a Sony service representative to replace the battery with a new one.	
Unknown Media(A) ¹⁾ Please Change.	WARNING indicator	Warning sound	Tally/REC	Battery remaining
	—	—	—	—
	Problem	Operation in the recorder module	Action to take	
	A partitioned memory card or one that contains recorded clips exceeding the number permitted with this camcorder is loaded.	Recording continues.	This card cannot be used with this camcorder. Remove it and load a compatible card.	
Reached Clip Number Limit Cannot Record to Media(A) ¹⁾	WARNING indicator	Warning sound	Tally/REC	Battery remaining
	—	—	—	—
	Problem	Operation in the recorder module	Action to take	
	The maximum number of clips for a single memory card is reached. No more clip can be recorded on the card.	Recording stops.	Replace it with another card.	
Media Error Media(A) ¹⁾ Needs to be Restored	WARNING indicator	Warning sound	Tally/REC	Battery remaining
	—	—	—	—
	Problem	Operation in the recorder module	Action to take	
	An error occurred with the memory card. The card requires restoration.	Recording stops.	Remove the card, load it again, and restore it.	
Media Error Cannot Record to Media(A) ¹⁾	WARNING indicator	Warning sound	Tally/REC	Battery remaining
	—	—	—	—
	Problem	Operation in the recorder module	Action to take	
	Recording cannot be done, as the memory card is defective.	Recording stops.	As playback may be possible, it is recommended to replace it with another card after copying the clips, as required.	

Media Error Cannot Use Media(A) ¹⁾	WARNING indicator	Warning sound	Tally/REC	Battery remaining
	—	—	—	—
	Problem	Operation in the recorder module	Action to take	
	Neither recording nor playback can be done, as the memory card is defective.	Recording stops.	It cannot be operated with this camcorder. Replace it with another card.	
Cannot Use Media(A) ¹⁾ Unsupported File System	WARNING indicator	Warning sound	Tally/REC	Battery remaining
	—	—	—	—
	Problem	Operation in the recorder module	Action to take	
	A card of a different file system was inserted.	Recording stops.	It cannot be used with this camcorder. Replace it with another card.	
Video Format Mismatch	WARNING indicator	Warning sound	Tally/REC	Battery remaining
	—	—	—	—
	Problem	Operation in the recorder module	Action to take	
	The external signal input via the i.LINK connection cannot be recorded, as the Video Format setting is different from the signal format of the external input signal.	Recording stops.	Change settings of OPERATION >Format in the setup menu to match it to that of the external signal.	
Copy Protected Input Cannot Record	WARNING indicator	Warning sound	Tally/REC	Battery remaining
	—	—	—	—
	Problem	Operation in the recorder module	Action to take	
	The external signal input via the i.LINK connection cannot be recorded, as the stream is copy-protected.	Recording stops.	Check the input signal.	
DVCAM Input Cannot Record	WARNING indicator	Warning sound	Tally/REC	Battery remaining
	—	—	—	—
	Problem	Operation in the recorder module	Action to take	
	The external signal input via the i.LINK connection cannot be recorded, as it is a DV stream.	Recording stops.	—	

Media Error Playback Halted	WARNING indicator	Warning sound	Tally/REC	Battery remaining
	—	—	—	—
	Problem	Operation in the recorder module	Action to take	
	An error occurred in reading data from the memory card, and playback cannot be continued.	Recording stops.	If this frequently occurs, change the memory card after copying the clips, as required.	
Media(A) ¹ Error	WARNING indicator	Warning sound	Tally/REC	Battery remaining
	—	—	—	—
	Problem	Operation in the recorder module	Action to take	
	Recording cannot be done, as an error occurred with the memory card.	Recording stops.	If this frequently occurs, change the memory card.	
HDD A ² Battery Near End	WARNING indicator	Warning sound	Tally/REC	Battery remaining
		●))))))))))		—
	Problem	Operation in the recorder module	Action to take	
	The battery power of the connected HDD will be exhausted soon.	Recording continues.	Change the battery at the earliest opportunity.	
HDD A ² Battery End	WARNING indicator	Warning sound	Tally/REC	Battery remaining
		●)))))))))))))		—
	Problem	Operation in the recorder module	Action to take	
	The battery of the connected HDD is exhausted. Recording cannot be performed.	Recording stops.	Stop operation to change the battery.	
Not Enough Capacity Change Media (A) ¹	WARNING indicator	Warning sound	Tally/REC	Battery remaining
	—	—	—	—
	Problem	Operation in the recorder module	Action to take	
	There is not enough capacity for copying.	Recording continues (disallowing copy).	Replace the card in slot A with another one.	

Reached Duplication Limit Change Media (A) ¹⁾	WARNING indicator	Warning sound	Tally/REC	Battery remaining
	—	—	—	—
	Problem	Operation in the recorder module	Action to take	
	The card has already ten clips having the same name as that you tried to duplicate.	Recording continues (disallowing copy).	Replace the card in slot A with another one.	
Not Enough Capacity Cannot Divide	WARNING indicator	Warning sound	Tally/REC	Battery remaining
	—	—	—	—
	Problem	Operation in the recorder module	Action to take	
	There is not enough capacity for dividing a clip.	Recording continues (disallowing divide).	—	
Will Switch Slots Soon	WARNING indicator	Warning sound	Tally/REC	Battery remaining
	—	—	—	—
	Problem	Operation in the recorder module	Action to take	
	Will switch to other slot soon.	Recording continues.	Make sure that a memory card is loaded in the other slot.	
No Clip	WARNING indicator	Warning sound	Tally/REC	Battery remaining
	—	—	—	—
	Problem	Operation in the recorder module	Action to take	
	There is no clip to be displayed.	Recording continues.	—	
No OK Clip	WARNING indicator	Warning sound	Tally/REC	Battery remaining
	—	—	—	—
	Problem	Operation in the recorder module	Action to take	
	There is no clip with the OK mark.	Recording continues.	—	
Same File Already Exists Change Media(A) ¹⁾	WARNING indicator	Warning sound	Tally/REC	Battery remaining
	—	—	—	—
	Problem	Operation in the recorder module	Action to take	
	The card has already clips having the same name as that you tried to duplicate.	Recording continues (disallowing copy).	Replace the card in slot A with another one.	

Serviceability Limit Reached Change Media (A) ¹⁾	WARNING indicator	Warning sound	Tally/REC	Battery remaining
	—	—	—	—
	Problem	Operation in the recorder module	Action to take	
	The memory card comes to the end of its service life.	Recording stops.	Make a backup copy and replace the card with another one as soon as possible. Recording/playback may not be performed properly if you continue to use the card. For details, refer to the operating instructions of the memory card.	

- 1) (B) for the card in slot B
- 2) B for a HDD connected to slot B

Appendix

Important Notes on Operation

Use and storage

Do not subject the camcorder to severe shocks

The internal mechanism may be damaged or the body warped.

Do not cover the camcorder while operating

Putting a cloth, for example, over the camcorder can cause excessive internal heat build-up.

After use

Always turn off the POWER switch.

Before storing the camcorder for a long period

Remove the battery pack.

Shipping

- Remove the media before transporting the camcorder.
- If sending the camcorder by truck, ship, air or other transportation service, pack it in the shipping carton of the camcorder.

Care of the camcorder

Remove dust and dirt from the surfaces of the lenses or optical filters using a blower.

If the body of the camcorder is dirty, clean it with a soft, dry cloth. In extreme cases, use a cloth steeped in a little neutral detergent, then wipe dry. Do not use organic solvents such as alcohol or thinners, as these may cause discoloration or other damage to the finish of the camcorder.

In the event of operating problems

If you should experience problems with the camcorder, contact a Sony service representative.

Use and storage locations

Store in a level, ventilated place. Avoid using or storing the camcorder in the following places.

- In excessive heat or cold (operating temperature range: 0°C to +40°C (32°F to 104°F))

- Remember that in summer in warm climates the temperature inside a car with the windows closed can easily exceed 50°C (122°F).
- In damp or dusty locations
- Locations where the camcorder may be exposed to rain
- Locations subject to violent vibration
- Near strong magnetic fields
- Close to radio or TV transmitters producing strong electromagnetic fields.
- In direct sunlight or close to heaters for extended periods

To prevent electromagnetic interference from portable communications devices

The use of portable telephones and other communications devices near this camcorder can result in malfunctions and interference with audio and video signals.

It is recommended that the portable communications devices near this camcorder be powered off.

Note on laser beams

Laser beams may damage the CMOS image sensors.

If you shoot a scene that includes a laser beam, be careful not to let the laser beam be directed into the lens of the camcorder.

Fitting the zoom lens

It is important to fit the lens correctly, as otherwise damage may result. *Be sure to refer to the section "Mounting and Adjusting the Lens" (page 41).*

Viewfinder

Do not leave the camcorder with the eyepiece pointing directly at the sun.

The eyepiece lens can concentrate the sun's rays and melt the interior of the viewfinder.

About the LCD panels

LCD panels are manufactured with extremely high-precision technology that yields effective pixel rates of 99.99% or higher. However, very rarely, one or more pixels may be permanently dark or permanently lit in white, red, blue, or green.

This phenomenon is not a malfunction. Such pixels have no effect on the recorded data, and the camcorder may be used with confidence even if they are present.

Phenomena specific to CMOS image sensors

The following phenomena that may appear in images are specific to CMOS (Complementary Metal Oxide Semiconductor) image sensors. They do not indicate malfunctions.

White flecks

Although the CMOS image sensors are produced with high-precision technologies, fine white flecks may be generated on the screen in rare cases, caused by cosmic rays, etc. This is related to the principle of CMOS image sensors and is not a malfunction.

The white flecks especially tend to be seen in the following cases:

- when operating at a high environmental temperature
- when you have raised the master gain (sensitivity)
- when operating in Slow-Shutter mode

The problem may be alleviated by executing automatic black balance adjustment.

Aliasing

When fine patterns, stripes, or lines are shot, they may appear jagged or flicker.

Flicker

If recording is made under lighting produced by discharge tubes, such as fluorescent, sodium, or mercury-vapor lamps, the screen may flicker, colors may vary, or horizontal stripes may appear distorted.



In such cases, set the flicker-reduction function to auto mode (*see page 125*).

If the frame rate selected for recording is close to the power-supply frequency, flicker may not be reduced sufficiently even if you activate the Flicker-Reduction function. In such cases, use the electronic shutter.

Focal plane

Owing to the characteristics of the pickup elements (CMOS image sensors) for reading video signals, subjects that quickly move across the screen may appear slightly skewed.

Flash band

The luminance at the top and bottom of the screen may change when shooting a flashlight beam or a light source that quickly flashes.

You can use the XDCAM EX Clip Browsing Software to correct clips that contain frames with flash bands.

Note on data compatibility with other XDCAM EX-series products

When you use a PMW-EX1/EX3/EX30 to play materials recorded on the camcorder, any media in which clips of formats not supported by the PMW-EX1/EX3/EX30 have been recorded cannot be used.

Fragmentation

If pictures cannot be recorded/reproduced properly, try formatting the recording medium. While repeating picture recording/playback with a certain recording medium for an extended period, files in the medium may be fragmented, disabling proper recording/storage. In such a case, make a backup of clips in the medium then perform formatting of the medium using OPERATION >Format Media (*see page 97*) in the setup menu.

Exchanging the Battery of the Internal Clock

The camcorder's internal clock is powered by a lithium battery. If the message "Back Up Battery End" appears in the viewfinder, this battery must be exchanged. Contact a Sony service representative.

Specifications

General

Power requirements

12 V DC (11 V to 17.0 V)

Power consumption

Approx. 18 W

Main unit (camcorder) + LCD viewfinder + auto focus lens + microphone

During recording, power source: battery pack

Notes

- Do not use a video light with power consumption of over 50 W.
- When connecting a device to the DC OUT connector, use one with current consumption of 0.5 A or more.

Operating temperature

0°C to +40°C (32°F to 104°F)

Storage temperature

-20°C to +60°C (-4°F to 140°F)

Recording/playback formats

Video

HD HQ Mode: MPEG-2 MP@HL, 35 Mbps/
VBR

1920 × 1080/59.94i, 50i, 29.97P, 25P,
23.98P

1440 × 1080/59.94i, 50P, 29.97P, 25P,
23.98P

1280 × 720/59.94P, 50P, 29.97P, 25P,
23.98P

HD SP Mode: MPEG-2 MP@H-14, 25 Mbps/
CBR

1440 × 1080 /59.94i, 50i
(23.98P is converted to 59.94i in 2-3 pull-
down processing.)

SD Mode: DVCAM (when the optional CBK-
DV01 is installed)

720 × 480/59.94i
720 × 576/50i
720 × 480/29.97P
720 × 576/25P

Audio

LPCM (16 bits, 48 kHz, HD: 4 channels, SD: 2 channels)

Recording/playback time

With one SBP-32

SP mode: Approx. 140 min.

HQ mode: Approx. 100 min.

DVCAM mode: Approx. 140 min.

Continuous operation time

With the BP-GL95

Approx. 310 min.

Mass

Main body only: 3.2 kg (7 lb 0.88 oz)

Dimensions

See page 160.

Supplied accessories

See page 159.

Camera Block

Pickup device

$\frac{2}{3}$ -type, CMOS image sensor

Effective picture elements:

1920 (H) × 1080 (V)

Format

3-chip RGB

Optical system

F1.4 prism system

ND filters

1: Clear

2: $\frac{1}{4}$ ND

3: $\frac{1}{16}$ ND

4: $\frac{1}{64}$ ND

Sensitivity

F12 (System frequency: 59.94i)

F13 (System frequency: 50i)

(2000lx, 89.9% reflection)

Minimum illumination

0.003 lx (F1.4, +42 dB, 64-frame accumulation)

Video S/N

56 dB (Noise Suppress Off)

59 dB (Noise Suppress On)

Horizontal resolution

1000TV lines or more

Gain

-3, 0, 3, 6, 9, 12, 18, 24, 30, 36, 42 dB, AGC

Shutter speed

59.94i/P, 50i/P: $\frac{1}{60}$ to $\frac{1}{2000}$ sec.

29.97P: $\frac{1}{40}$ to $\frac{1}{2000}$ sec.

25P: $\frac{1}{33}$ to $\frac{1}{2000}$ sec.

23.94P: $\frac{1}{32}$ to $\frac{1}{2000}$ sec.

Slow shutter

2 to 8, 16, 32, 64 frames

Audio Block

Sampling frequency

48 kHz

Quantization

16 bits

Headroom

20 dB (the factory default setting)

(20, 18, 16, 12 dB)

Frequency response

MIC: 50 Hz to 20 kHz (within ± 3 dB)

LINE: 20 Hz to 20 kHz (within ± 3 dB)

WRR Analog: 50 Hz to 20 kHz (within ± 3 dB)

WRR Digital: 20 Hz to 20 kHz (within ± 3 dB)

Dynamic range

90 dB (typical)

Distortion

0.08% max. (with input level 40dBu)

Built-in speaker

Monaural

Output: 300 mW

Display

Viewfinder (supplied)

Screen size

8.8 cm diagonal (3.5-inch)

Aspect ratio

16:9

Picture elements

640 (H) × 3 × 480 (V) Sequence delta

Media Block

Card slots

Type: Express Card34

Number of slots: 2

Connector: Conforms to PCMCIA Express Card Standard

Writing rate

50 Mbps or more

Reading rate

50 Mbps or more

Inputs/Outputs

Input/Output connectors

Signal inputs

AUDIO IN CH-1/CH-2: XLR type, 3-pin, female

-60 dBu/-4 dBu (0 dBu=0.775 Vrms)

MIC IN: XLR type, 5-pin, female

-60 dBu

GENLOCK IN: BNC type

1.0 Vp-p, 75 Ω, unbalanced

TC IN: BNC type

0.5 V to 18 Vp-p, 10 kΩ

Signal outputs

VIDEO OUT: BNC type

TC OUT: BNC type

HDMI: Type A, 19-pin

HD/SD SDI OUT 1/2: BNC type

AUDIO OUT: XLR type, 5-pin, male
0 dBu

TC OUT: BNC type

1.0 Vp-p, 75 Ω

EARPHONE (minijack)

8 Ω, -∞ to -18 dBs variable

Others

DC IN: XLR type, 4-pin, male

11 to 17 V DC

DC OUT: 4-pin

11 to 17 V DC, maximum rated current:

0.5 A

LENS: 12-pin

Supplying power to the lens

11 to 17 V DC, maximum rated current:

1.0 A

REMOTE: 8-pin

LIGHT: 2-pin

USB: 4-pin

i.LINK (HDV/DV): 6-pin, complies with IEEE1394

VF: 26-pin, rectangular, 20-pin round

For wireless receiver: 15-pin, DSUB

Lens Block (PMW-350K only)

Focal length

8 mm ($1\frac{1}{32}$ inches) to 128 mm ($5\frac{1}{8}$ inches)
(equivalent to 31.5 mm ($1\frac{1}{4}$ inches) to
503 mm ($19\frac{7}{8}$ inches) on 35 mm
($1\frac{7}{16}$ inches) lens)

Zoom

Servo/Manual selectable

Zoom ratio

16×

Maximum relative aperture

1:1.9

Iris

Auto/Manual selectable

F1.9 to F16 and C (close)

Focus

Auto/Manual selectable

Ranges:

800 mm ($31\frac{1}{2}$ inches) to ∞ (Macro OFF)

50 mm (2 inches) to ∞ (Macro ON, Wide)

Filter thread

M82 mm, pitch 0.75 mm

Macro

ON/OFF switchable

Supplied Accessories

Viewfinder (1)

Shoulder strap (1)

Stereo microphone (1)

Windscreen (1)

Lens mount cap

Flange back adjustment chart

Auto focus lens (supplied with the PMW-350K) (1)

Operating Instructions

English version (1)

CD-ROM

- Utility Software for Solid-State Memory

Camcorder and Recorder (XDCAM EX Clip

Browsing Software, SxS Device Driver

Software) (1)

- Manuals for Solid-State Memory Camcorder

(PDF Operating Instructions and Supplement)

(1)

SxS Device Driver Software End-User License

Agreement (1)

Recommended Additional Equipment

DVCAM Record and Playback Option

SD Record and Playback Key
CBK-DV01

Power supply and related equipment

AC Adaptor
AC-DN10/DN2B

Battery Pack
BP-GL95/GL65/L80S/L60S

Battery Charger
BC-M150/L500/L70

Lens, Viewfinder and Related Equipment

Lens
 $\frac{2}{3}$ -type bayonet mount lenses only

Viewfinder
DXF-20W/51

Viewfinder Rotation Bracket
BKW-401

Note

The viewfinder able to use the BKW-401 is DXF-20W besides the supplied camcorder.

Equipment for remote control

Remote Control Unit
RM-B150/B750

Media

S×S Memory Card
S×S PRO SBP-8 (8 GB)
S×S PRO SBP-16 (16 GB)
S×S PRO SBP-32 (32 GB)
S×S-1 SBS-32G1 (32 GB)

Hard Disk Unit
PHU-60K/120K/120R

Media Adaptor
MEAD-MS01

Audio equipment

Microphone
ECM-678/674/673/680S

Microphone Holder
CAC-12 compatible

Wireless Microphone
DWR-S01D
WRR-855S/860A/861/862

Other peripheral devices

Tripod adaptor
VCT-14/U14

Video Light
Ultralight (Anton Bauer)

Pad
CBK-SP01 DynaFit Shoulder Pad (soft type)

Equipment for maintenance and easier handling

Hard Carrying Case
LC-H300

Soft Carrying Case
LC-DS300SFT

Maintenance Manual

Dimensions

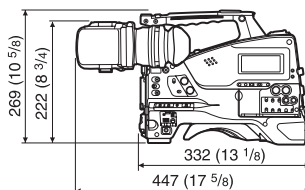
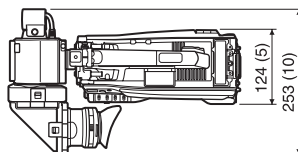

(in mm (inches))

Design and specifications are subject to change without notice.

Notes

- Always make a test recording, and verify that it was recorded successfully.
SONY WILL NOT BE LIABLE FOR DAMAGES OF ANY KIND INCLUDING, BUT NOT LIMITED TO, COMPENSATION OR REIMBURSEMENT ON ACCOUNT OF FAILURE OF THIS UNIT OR ITS RECORDING MEDIA, EXTERNAL STORAGE SYSTEMS OR ANY OTHER MEDIA OR STORAGE SYSTEMS TO RECORD CONTENT OF ANY TYPE.
- Always verify that the unit is operating properly before use. SONY WILL NOT BE LIABLE FOR DAMAGES OF ANY KIND INCLUDING, BUT NOT LIMITED TO, COMPENSATION OR REIMBURSEMENT ON ACCOUNT OF THE LOSS OF PRESENT OR PROSPECTIVE PROFITS DUE TO FAILURE OF THIS UNIT, EITHER DURING THE WARRANTY PERIOD OR AFTER EXPIRATION OF THE WARRANTY, OR FOR ANY OTHER REASON WHATSOEVER.

Chart of Optional Components and Accessories

Appendix

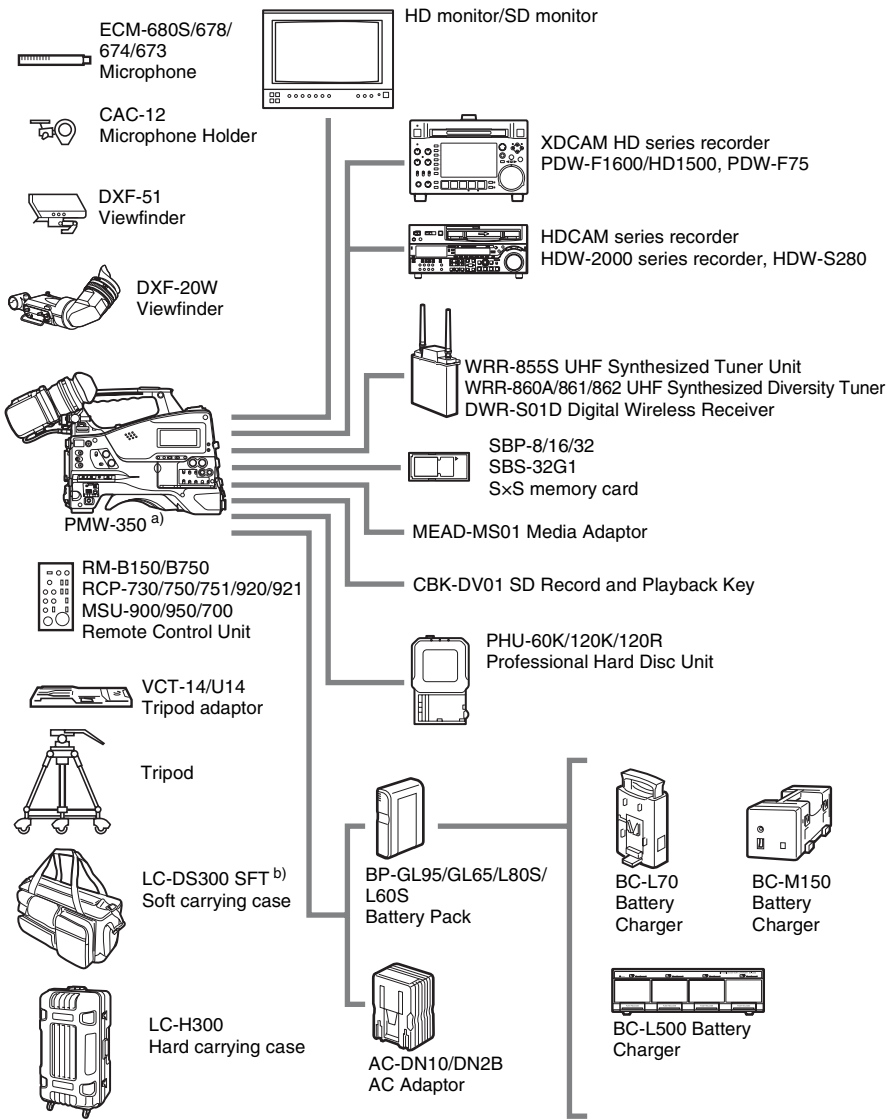

a) The PMW-350L requires a separately sold lens.

b) The carrying case is large enough to hold the camcorder with lens and microphone mounted. However, remove them if they protrude more than 25 cm (9 7/8 inches) from the front of the main unit.

About i.LINK

This section explains the specifications and features of i.LINK.

What is i.LINK?

i.LINK is a digital serial interface designed to integrate devices equipped with i.LINK connectors. i.LINK allows your device to:

- Perform two-way transmission and reception of data such as digital audio and digital video signals.
- Control other i.LINK devices.
- Easily connect multiple devices with a single i.LINK cable.

Your i.LINK device is capable of connecting to a wide range of digital AV devices for data transfer and other operations.

Other advantages include the following feature.

When connected to multiple i.LINK devices, your i.LINK device can perform data transfer and other operations not only

with the directly connected devices but also with any of the devices that are connected to those devices. Therefore, you do not need to be concerned with device connection order. However, depending on the features and specifications of the connected devices, you may need to use certain functions differently, and you may not be able to transfer data or perform certain operations.

i.LINK, a nickname for IEEE 1394 proposed by Sony, is a trademark supported by many companies worldwide.

IEEE 1394 is an international standard defined by IEEE, the Institute of Electrical and Electronics Engineers, Inc.

Note

The camcorder can be connected to one device with the i.LINK cable (DV cable). When you connect with an HDV or DV device that has two or more i.LINK connectors, refer to the operating instructions supplied with the connected device.

About data transfer speed of i.LINK

i.LINK defines a maximum data transfer speed of approximately 100, 200 and 400 Mbps¹⁾ that are described as S100, S200 and S400 respectively. For i.LINK devices, a maximum data transfer speed that the device supports is identified on “Specifications” page of the operating instructions supplied with the device or near its i.LINK connector.

- 1) When connecting with the device that support different data transfer speed, the actual data transfer speed may be different from those described on the i.LINK connectors.

What is Mbps?

Mega bits per second. A measure of the rate at which data is transmitted per second. In case of 100 Mbps, 100 Mega bits of data can be transmitted per second.

i.LINK operation with your camcorder

For details on operation when other equipment with i.LINK (HDV or DV) connector is connected, see page 144.

For details on connection with i.LINK cable and necessary software, refer to the operating instructions supplied with the connected device.

About the required i.LINK cable

Use the Sony 6-pin-to-4-pin or 6-pin-to-6-pin i.LINK cable to connect the i.LINK devices.

i.LINK and  are trademarks.

MPEG-2 Video Patent Portfolio License

ANY USE OF THIS PRODUCT OTHER THAN CONSUMER PERSONAL USE IN ANY MANNER THAT COMPLIES WITH THE MPEG-2 STANDARD FOR ENCODING VIDEO INFORMATION FOR PACKAGED MEDIA IS EXPRESSLY PROHIBITED WITHOUT A LICENSE UNDER APPLICABLE PATENTS IN THE MPEG-2 PATENT PORTFOLIO, WHICH LICENSE IS AVAILABLE FROM MPEG LA, L.L.C., 250 STEELE STREET, SUITE 300, DENVER, COLORADO 80206.

“PACKAGED MEDIA” means any storage media storing MPEG-2 video information such as DVD movie which are sold/distributed to general consumers. Disc replicators or sellers of the PACKAGED MEDIA need to obtain licenses for their own business from MPEG LA. Please contact MPEG LA for any further information. MPEG LA, L.L.C., 250 STEELE STREET, SUITE 300, DENVER, COLORADO 80206
<http://www.mpegla.com>

Index

A

- AC power 34
- ACCESS lamps 20, 23
- Accessories (optional) 162
- ALARM knob 17
- Area setting 40
- Arrow buttons (←, →, ↑, ↓) 21
- ASSIGN. 0 switch 18
- ASSIGN. 1/2/3 switches 17
- ASSIGNABLE 4/5 switches 23
- Assignable switches, assigning functions 131
- ATW (Auto Tracing White Balance) 18
- Audio control section 21
- AUDIO IN CH1/CH2 connectors 24
- AUDIO IN CH-1/CH-2/CH-3/CH-4 switches 22
- AUDIO IN selectors 24
- Audio input system 43
- Audio level
 - adjusting 60
 - adjusting playback level 17
 - meters 31
- AUDIO OUT connector 24
- AUDIO SELECT CH-1/CH-2 switches 22
- AUTO W/B BAL switch 16

B

- BACKLIGHT button 21
- Battery
 - attachment shoe 14
 - of the internal clock, exchanging 157
 - pack 33
 - remaining 30
- BKW-401 37
- Black balance, adjusting 51
- BRIGHT control 28

C

- Clip(s)
 - batch copy 88

- copying 87
- cue up 83
- deleting 73, 88
- displaying properties 86
- dividing 91
- operating with a computer 142
- operations 80
- playing 72, 82
- selecting 82

- Clock setting 41
- Color LCD 19
- COLOR TEMP. button 17
- Color temperature 30
- Computer, connecting 142
- Connection 140
 - computer 142
 - monitors 140
 - using i.LINK 144
 - using USB 142
- CONTRAST control 28
- Cover 19

D

- Date, setting 41
- DC IN connector 14
- DC OUT 12V connector 14
- DCC (Dynamic Contrast Control) 18
- Depth of field 30
- Diopter adjustment ring 27
- DISPLAY switches 21, 28

E

- EARPHONE jack 24
- EJECT buttons 23
- Electric color temperature filter 31
- ESSENCE MARK button 22
- EXPAND button 20
- Expand thumbnail screen
 - displaying 88
 - to increase the number of divisions 89
- Extender 29
- External devices 140
 - control 31
- External input 31
- External power source 30
- Eyecup 27

F

- F FWD button/indicator 20
- F REV button/indicator 20
- FILTER selector 16
- Fitting for optional microphone holder 15
- Flange focal length, adjusting 26, 42
- Focus
 - adjusting 58
 - adjustment mode 30
 - position 29
 - ring 26
- FOCUS switch 26
- Frame Rec 77
- Framing shots 79
- Freeze Mix 79
- F-RUN/SET/R-RUN switch 21

G

- GAIN selector 18
- Gain value 31
- GENLOCK IN connector 23
- Green tally 29

H

- HD/SD SDI OUT connector 24
- HDMI output connector 23
- Histogram 31
- HOLD button 20

I

- i.LINK 163
 - cable 163
 - connection 144
- i.LINK (HDV/DV) connector 25
- Index picture 81
 - changing 90
- Initial value 95
- Input source 31
- Internal clock 41
- Interval Rec 75
- Iris
 - position 31
 - ring 26
- IRIS switch 27

L

- LCD panel 19
- Lens
 - cable clamp 15
 - locking lever 15
 - mount 15
 - mount cap 15
 - mount securing rubber 15
 - mounting 41
- LENS connector 15
- Lens file(s)
 - loading 138
 - loading automatically 139
 - saving 138
 - setting data 138
- LEVEL CH-1/CH-2/CH-3/CH-4 knobs 22
- LIGHT connector 15
- Light fitting shoe 14
- LIGHT switch 14

M

- MACRO switch 26
- Maintenance 147
- Media
 - remaining capacity 31
 - status 29
- MENU button 21
- MENU CANCEL/PRST/ESCAPE switch 18
- MENU knob 16
- MENU ON/OFF switch 18
- MIC IN (+48 V) connector 15
- MIC LEVEL control 16
- Microphone holder 28
 - fitting 15
- Microphone, connecting 43
- MIRROR switch 28
- MONITOR knob 17
- MONITOR switches 17
- Monitor, connecting 140
- Monochrome LCD Panel 25

N

- ND filter 16, 31
- NEXT button 20
- Nonlinear editing 144, 145
- Number of system lines 30

O

- OK mark(s) 81, 86
 - adding 87
 - deleting 87
 - setting 73
- Operation status 29
 - of i.LINK device 31
- Optional components 162
- OUTPUT/DCC switch 18

P

- PEAKING control 28
- Picture Cache 74
- PLAY/PAUSE button/indicator 20
- Plug 27
- Power source voltage/battery remaining capacity 30
- Power supply 33
- POWER switch 14
- Preset values, resetting 136
- PRESET/REGEN/CLOCK switch 22
- PREV button 20
- PUSH AF button 26
- PUSH AUTO button 27

R

- REC START button 16
- Recording
 - external input signals 145
 - from pre-stored video 74
 - on an external device 144
 - remaining time 70
 - review 72
 - time-lapse video 75
- Recording mode 29
 - special settings indication 30
- REMOTE connector 25
- Reset 95, 136
- RESET/RETURN button 20
- RET button 27

S

- S×S Device Driver Software 12
- S×S memory card slots 23
- S×S memory cards 67
 - ejecting 69

- formatting 69
- loading 68
- restoring 70
- selecting 69

Scene files

- loading 137
- saving 137

Search

- with the expand thumbnail screen 83
- with the shot mark thumbnail screen 83

SET button 21

Setup menu 92

- basic operations 94
- FILE menu 127
- MAINTENANCE menu 115
- menu list 96
- OPERATION menu 96
- PAINT menu 109

SHIFT button 22

Shooting 67

- basic operations 71
- stop motion animations 77
- with Slow & Quick motion 78

Shot mark thumbnail screen 89

Shot mark(s)

- adding 90
- adding during playback 83
- deleting 90
- recording 73

Shoulder pad 15

- adjusting the position 49

Shoulder strap fitting 14

Shoulder strap, using 48

Shutter

- setting 55
- speed 31

SHUTTER selector 16

Slot cover 23

SLOT SELECT button 23

Speaker 19

Specifications 157

Status information 65

STATUS ON/SEL/OFF switch 18

Status screens 65

- ASSIGN SWITCH 65

- AUDIO 65

- BATTERY/MEDIA 66

- CAMERA 65

- VIDEO 65

STOP button 20

Stopper 27

T

TALLY indicators 24

Tally indicators 28

TALLY switch 24, 28

TC IN connector 24

TC OUT connector 24

TCLS automatic adjustment 57

Testing 147

THUMBNAIL button 21

THUMBNAIL indicator 21

THUMBNAIL menu 84
operations 85

Thumbnail screen 80

displaying OK clip thumbnails only 85

displaying the all clips thumbnail 85

Thumbnail(s)

changing the screen type 85

operations 84

Time, setting 41

Timecode 31

setting 62

synchronizing 63

TLCS control mode 30

Tripod mount 15

Tripod, mounting 46

U

UHF portable tuner, attaching 45

USB connection 142

USB connector 23

User bits setting 63

User setting data

loading 136

saving 135

V

VF connector 15

Video format 30, 87

setting 50

Video level indication 31

Video light, connecting 47

VIDEO OUT connector 24

Viewfinder 27

adjusting focus 37

adjusting position 35

adjusting screen 37

adjusting the angle 36

attaching 35

attaching a 5-inch viewfinder 38

cable 28

cleaning 147

connectors 15

fitting shoe 15

positioning knob 15

positioning lever 15

positioning ring 15

raising up the barrel and eyepiece 36

screen display 29

Voltage capacity 30

W

WARNING indicator 20

Warnings 148

WHITE BAL switch 18

White balance memory 31

White balance, adjusting 52

Wireless microphone reception level 30

X

XDCAM EX Clip Browsing Software 12,
143

XDCAM EX web sites 12

Z

ZEBRA switch 28

Zoom 58

control connector 26

position 29

power zoom lever 27

ring 26

ZOOM switch 26

